

RADIO CRAFT



ELECTRONIC
ARTILLERY LOCATOR
SEE PAGE 207

ALEX
SCHOMBURG

JAN
1945

25¢

CANADA 30¢

RADIO-ELECTRONICS IN ALL ITS PHASES

"MEET YOUR NAVY"

Now Carries the RAYTHEON Name
Into 3,500,000 Radio Homes Each Week!

★ ACTUAL BATTLE EXPERIENCES

★ 65 BLUEJACKET MUSICIANS

★ 200 BLUEJACKET VOICES

★ TALENTED BLUEJACKET SOLOISTS

RAYTHEON MANUFACTURING COMPANY • Newton and Waltham, Massachusetts

Every Saturday Night
BLUE NETWORK
Coast-to-Coast



All Four Raytheon Divisions Have Been
Awarded Army-Navy "E" Plus Stars



RAYTHEON

High Fidelity

RADIO AND ELECTRONIC TUBES



DEVOTED TO RESEARCH AND THE MANUFACTURE OF TUBES AND EQUIPMENT FOR THE NEW ERA OF ELECTRONICS

CHECK on this "QUICK-CHECK" Feature of the Solar Capacitor Analyzer . . .



THE SOLAR MODEL CE Capacitor Examiner speedily locates common defects in capacitors without disconnecting condensers—often eliminating further tests. This saving of time and labor is accomplished by the unique Solar "QUICK-CHECK" feature.

In this *single* instrument are combined the simplest, most convenient methods for examining the true condition of every capacitor in ordinary use . . . shorts, opens, intermittents, high R.F. impedance and high power factor.

Catalog IN-1 illustrates and describes features of all models. Send for your copy today.



Solar Mfg. Co.

ANOTHER HELPFUL SOLAR SERVICE

SOLAR CAPACITOR SALES CORP.
285 Madison Avenue, New York 17, N. Y.

Please send me a copy of Catalog IN-1 on Solar CAPACITOR ANALYZERS.

Name _____

Title _____

Company Name _____

Street Address _____

City _____ State _____

SEND THIS COUPON IN—TODAY



After The war, MORE than before!

COUNT ON THE FAMOUS N. U. EQUIPMENT PLAN

Of course, you'll need new shop equipment to cope with the vastly increased peacetime demand for radio, television and industrial electronic service. You'll want fine, modern instruments, tools, meters. And you'll want them, as before, on the easy-to-get basis provided by the famous N. U. Equipment Plan.

Fifty thousand times this plan was Ok'd by service dealers who used it to equip their shops in the years before the war. So plan now to re-equip for peacetime service, the exclusive N. U. way.

**NATIONAL UNION RADIO CORPORATION
NEWARK 2, NEW JERSEY**

Factories: Newark and Maplewood, N.J.; Lansdale and Robesonia, Pa.

**NATIONAL UNION
RADIO AND ELECTRONIC TUBES**



Transmitting, Cathode Ray, Receiving, Special Purpose Tubes • Condensers • Volume Controls • Photo Electric Cells • Panel Lamps • Flashlight Bulbs

Get this FREE Lesson in Radio

Gives you a real start toward understanding these subjects

With 31 Photos, Sketches, Radio Drawings

How superheterodyne circuits work
How to remove tubes, tube shields
Three reasons why Radio tubes fail
Electrodynamic loudspeaker:

How it works
Replacing damaged cone
Recentering voice coil
Remedies for open field coil
Output transformer construction, repair
Gang Tuning condenser:
Construction of rotor, stator
How capacity varies

Restringing dial cord
Straightening bent rotor plates
I.F. transformers:
What they do, repair hints
How to locate defective soldered joints
Inside story of carbon resistors
Paper, electrolytic, mica, trimmer
condensers
How condensers become shorted, leaky
Antenna, oscillator coil facts
Power transformer:
Construction, possible troubles

Installing power cord
Troubles of combination volume control, on-off switch
Tone controls
Dial lamp connections
Receiver servicing technique:
Checking performance
Testing tubes
Circuit disturbance test
Isolating defective stage
Locating defective part

GETTING ACQUAINTED WITH RECEIVER SERVICING



See For Yourself How I Train You at Home to BE A RADIO TECHNICIAN

I want to give every man who's interested in Radio, either professionally or as a hobby, a copy of my Lesson, "Getting Acquainted With Receiver Servicing"—absolutely FREE! It's a valuable lesson. Study it—keep it—use it—without obligation! And with it I'll send my 64-page, illustrated book, "Win Rich Rewards in Radio," FREE. It describes many fascinating jobs in Radio, tells how N.R.I. trains you at home in spare time, how you get practical experience with SIX KITS OF RADIO PARTS I send.

This "sample" Lesson will show you why the easy-to-grasp lessons of the N.R.I. Course have paved the way to good pay for hundreds of other men. I will send it to you without obligation. MAIL THE COUPON!

I Trained These Men

\$200 Month in Own Business



"I am in business for myself making around \$200 a month." — writes Arlie J. Froehner, 300 W. Texas Avenue, Goose Creek, Texas.

\$600 a Year in Spare Time



"Doing spare time radio work. I earned money in radio before graduating. Profit last 12 months was \$600." — E. F. Boettcher, Marinette, Wis.

Communication Station Operator "Am with Civil Aeronautics Administration at Shreveport Airways Communication station. Have a lifetime position with pension after retirement." — Jesso Roberts, Box 1076, Shreveport, La.



Chief Operator Broadcasting Station "Before I completed your lessons, I obtained my Radio Operator's license and joined Station WMPC where I am now Chief Operator." — Hollis F. Hayes, 327 Madison St., Lapeer, Michigan.



Future Looks Bright

For Well-Trained Radio Technicians, Operators

Many good pay opportunities are ahead for capable, well-trained Radio Technicians and Operators. The Radio Repair Business is booming. Profits are large and prospects are bright. Broadcasting Stations, Aviation and Police Radio, Loudspeaker Systems and Radio Manufacturers all give good jobs to trained radio men. And think of the NEW jobs that Television, Electronics, and Frequency Modulation will open up in the future!

Many Beginners Soon Make \$5, \$10 a Week EXTRA in Spare Time

As soon as you enroll for my Course I start sending you EXTRA MONEY JOB SHEETS that help show you how to earn \$5 to \$10 a week EXTRA in spare time while still learning.

Mail Coupon for Free Lesson and Book

The opportunity now offered beginners to get started in Radio may never be repeated. So take the first step at once. Get my FREE Lesson and 64-page, illustrated book. No obligation. Just mail coupon in an envelope or paste it on a penny postal. — J. E. SMITH, President, Dept. 5AX, National Radio Institute, Washington 9, D. C.

OUR 31ST YEAR OF TRAINING MEN FOR SUCCESS IN RADIO

GOOD FOR BOTH 64 PAGE BOOK SAMPLE LESSON FREE

Mr. J. E. Smith, President, Dept. 5AX
NATIONAL RADIO INSTITUTE, Washington 9, D. C.

Mail me FREE, without obligation, Sample Lesson and 64-page book, "Win Rich Rewards in Radio." (No salesman will call. Please write plainly.)

Age.....

Name.....

Address.....

City..... Zone..... State..... 4FR

You Build These and Many Other Radio Circuits with 6 Kits of Parts I Supply

By the time you've conducted 60 sets of Experiments, made hundreds of measurements and adjustments, you'll have valuable PRACTICAL Radio experience.

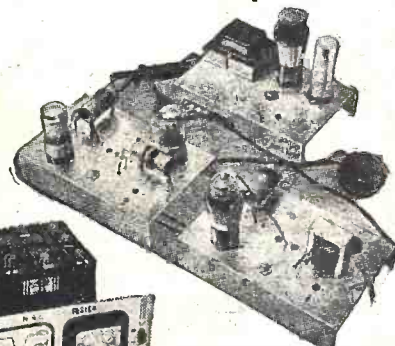

You build MEASURING INSTRUMENT above early in Course, useful for Radio work to pick up EXTRA spare time money. It is a vacuum tube multimeter, measures A.C., D.C., R.F. volts, D.C. currents, resistance, receiver output.

You build the SUPERHETERODYNE CIRCUIT above containing a preselector oscillator-mixer-first detector, i.f. stage, diode-detector-a.v.c. stage and audio stage. It will bring in local and distant stations. Get the thrill of learning in spare time while you put the set through fascinating tests!



Building the A. M. SIGNAL GENERATOR at right will give you valuable experience. Provides amplitude-modulated signals for test and experimental purposes.



My Radio Course Includes TELEVISION • ELECTRONICS FREQUENCY MODULATION



Incorporating
SHORT WAVE CRAFT RADIO & TELEVISION

MEMBER
AUDIT BUREAU OF CIRCULATIONS

HUGO GERNSBACK, *Editor-in-Chief*
FRED SHUNAMAN, *Associate Editor*
I. QUEEN, *Editorial Associate*
ELMER FULLER, *Shortwave Editor*
A. PASCALE, *Production Manager*
G. ALIQUO, *Circulation Manager*
JOHN J. LAMSON, *Advertising Director*
ALFRED STERN, *Promotion Manager*

IN THE NEXT ISSUE

Resistance and Capacity Bridge
Loudspeaker Cross-over Network
Radio Aircraft Landing System
An FM-Type Phonograph Pickup
A Primer of Aviation Radio

Published by Radercraft Publications, Inc.
Publication Office: 29 Worthington Street,
Springfield 3, Mass.
Editorial and Advertising Offices: 25 West
Broadway, Tel. RE2-9690, New York 7, N. Y.
Chicago Advertising Office: Radio-Craft, 520
North Michigan Avenue, Tel. Superior 7306,
Chicago 11, Ill.
Cleveland Advertising Office: 405 Erie Bldg.,
Cleveland, Ohio. Burdette Phillips, Manager.
Tel. Main 9645.

Los Angeles Office: Robt. H. Deibler & Associates,
403 W. Eighth St., Tucker 1579.
RADIO-CRAFT is published monthly on the
25th of the month preceding that of date;
subscription price is \$2.50 per year in U. S.
(In foreign countries, 75c additional per year
to cover postage; Canada, 50c additional.)
Special rates for members of the Armed Forces
in U. S., or those addressed by A.P.O. or F.P.O.
mail, \$2.00. Entered at the post office at
Springfield as second-class matter under the
Act of March 3, 1879. All communications
about subscriptions should be addressed to:
Circulation Manager, Radio-Craft, 29 Worthington
St., Springfield 3, Mass.

Notice of CHANGE of ADDRESS should
reach us at least one month in advance. When
ordering a change, please furnish an address
stencil impression from a recent wrapper if
you can. Address changes cannot be made
without the old address as well as the new.

Foreign Agents

London—Atlas Publishing and Distributing
Co., Ltd., 18 Bride Lane, Fleet St., London,
E.C. 4.
Melbourne—McGill's Agency, 179 Elizabeth
St., Australia.

Text and illustrations of this magazine are
copyright and must not be reproduced without
permission of the copyright owners.
Copyright, 1944, Radercraft Publications, Inc.

Contents January, 1945 Volume XVI, No. 4

Editorial: Post-War Servicing Opportunities.....	by Hugo Gernsback	203
Radio-Electronics Monthly Review.....		205
40 Years of Home Radio.....	by Hugo Gernsback	209
Dots and Dashes.....	by H. E. Leigh	251

ELECTRONICS

Communication by Induction.....	by R. W. Hale	206
Fungus—Enemy of Radio Sets.....		208
Special Tubes.....		213
Electronic Dictation.....	by Phil Glanzer	214
Electronic Symbols.....	by Fred Shunaman	215

WARTIME RADIO

Electronic Gun Locator.....	by Sydney Weinrib	207
A Radio Robot Conyoy.....	by I. Queen	212

RADIO TRAINING

Broadcast Equipment, Part V.....	by Don C. Hoefler	211
----------------------------------	-------------------	-----

SOUND

The Remote Juke Box.....	by Kent B. Young	210
Speech Amplifier, Part IV.....	by Robert F. Scott	218

SERVICING

"Station Riding".....	by Leo G. Sands	216
Characteristics of Electronic Guitars.....	by Robert Smith	217

CONSTRUCTION

A Magnetic Recorder.....	by Warren M. Davis	220
Super-Regenerator.....	by Homer L. Davidson	221

TEST INSTRUMENTS

Emergency Ohmmeter.....	by A. P. Nielsen	219
-------------------------	------------------	-----

DEPARTMENTS

New Radio-Electronic Devices.....		222
World-Wide Station List.....	by Elmer R. Fuller	223
Radio-Electronic Circuits.....		224
The Question Box.....		226
Try This One!.....		228
Progress in Invention.....	Conducted by I. Queen	230
Technotes.....		248
The Mail Bag.....		252
Book Reviews.....		255



ON THE COVER

The cover this month shows an electronic gun locator of the type now used by our artillery. Sounds are picked up by three or more microphones as widely separated as possible. These signals are sent by wire or radio to the main panel, where they are triangulated automatically and the enemy's range and position computed.

new directions in radio . . .

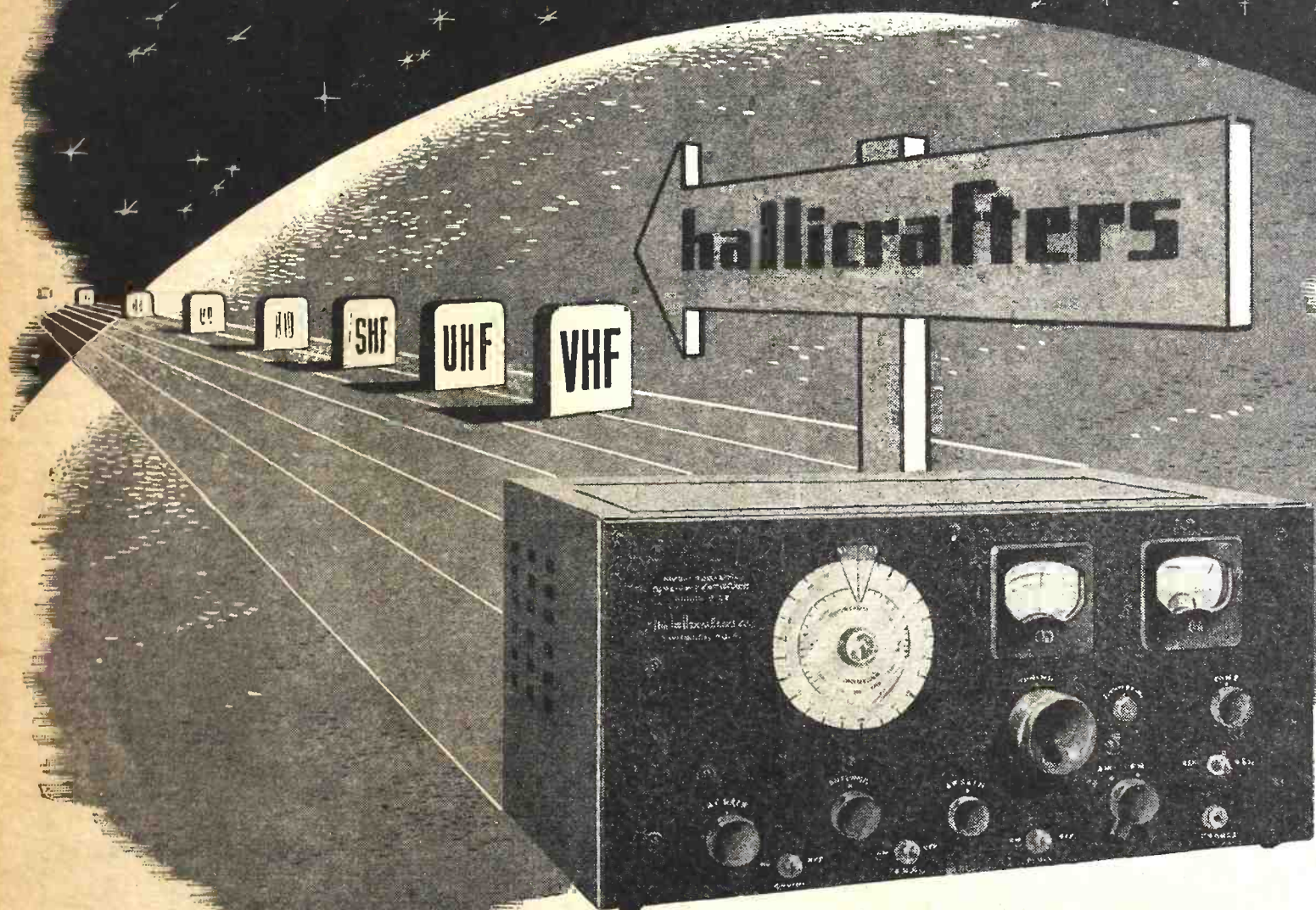

*New directions
in radio will
be charted by
Hallicrafters*

As radio development moves onward and upward, Hallicrafters engineers are setting the pace, pushing back the horizons in the exciting fields of very high frequency, ultra high frequency, and super high frequency development work. The range of the Model S-37 illustrated here covers higher frequencies than any other continuous tuning commercial type receiver. It is becoming a prime instrument of experiment and research in marking out the new directions that all radio will take.



hallicrafters RADIO

Buy a War Bond Today!



THE HALLICRAFTERS CO., MANUFACTURERS OF RADIO AND ELECTRONIC EQUIPMENT, CHICAGO 16, U. S. A.

SYLVANIA NEWS

RADIO SERVICE EDITION

JANUARY

Published in the Interest of Better Sight and Sound

1945

**SYLVANIA
SERVICEMAN
SERVICE**

by
FRANK FAX



Neat, attractively styled service garments make a good impression on customers and save wear and tear on ordinary clothes.

For wear in the shop, working on auto radios, or even in customers' homes, Sylvania offers well tailored, practical service coats and jackets. Made of serviceable double-strength herringbone weave dungaree cloth in a green and white mixture, giving a tweed effect, both garments are provided with roomy pockets. Jacket is of single breasted three button style with full sleeves, while coat has a special button arrangement which allows for tails to be buttoned in front, offering added trouser protection when kneeling.



Available in five popular sizes—36, 38, 40, 42 and 44, coats are priced at \$1.95 each, jackets in same sizes at \$1.75.

Order from your local Sylvania distributor, or send your order to Frank Fax, Sylvania, Emporium, Pa.

Servicemen Find Plenty of Ideas in Sylvania's Model Shop Layout

Booklet Packed With Helpful Hints On Low-Cost Steps in Modernization

Servicemen can do more than dream about that model service shop. For Sylvania comes through with plenty of practical, down-to-earth suggestions in "The Sylvania Model Service Shop," the book prepared to help radio servicemen modernize their shops at a cost compatible with earnings.

REWIRING SETS AIDS BUSINESS

Servicemen who have been revamping sets to meet wartime shortages of tubes have not only been doing a fine job for their customers, but they have also been building up future business for themselves.

When tubes and other replacement parts are freely available, servicemen will have an opportunity to restore sets to their original circuits. Customers whose sets were kept operating by emergency revamping will naturally come back to the serviceman who helped them.

Future repair jobs will be simplified by the wide use which servicemen made of the Sylvania Warning Cards. These cards show the changes made in the set, and thus save the serviceman valuable time in restoring the receiver to its original condition.

The book describes an actual shop designed and built by Sylvania with three things in mind: economy, efficiency and attractive layout. Every section of the model shop is described in full detail, from entrance, through office and testing department to repair section. Clearly written descriptions are supplemented by readily

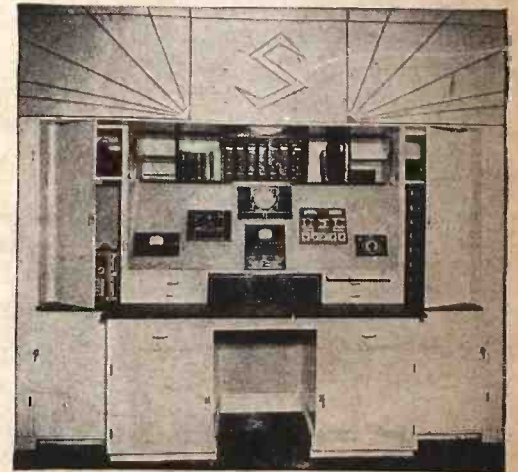

Here is the actual Model Shop built by Sylvania to help servicemen with their modernization plans.

understandable floor plans, and all recommendations are practical ones. A handy list of important instruments, tools and equipment that every shop should have is also included.

Whether he wants to "start from scratch" or merely make a few minor changes, every serviceman will find the "Sylvania Model Service Shop" a valuable guide in improving the appearance and efficiency of his shop. Nor will he have to wait until after the war, because many of the ideas can be put into effect right now by resourceful servicemen.

Price of the book is ten cents, and it may be obtained from Sylvania Electric Products Inc. Emporium, Pennsylvania.

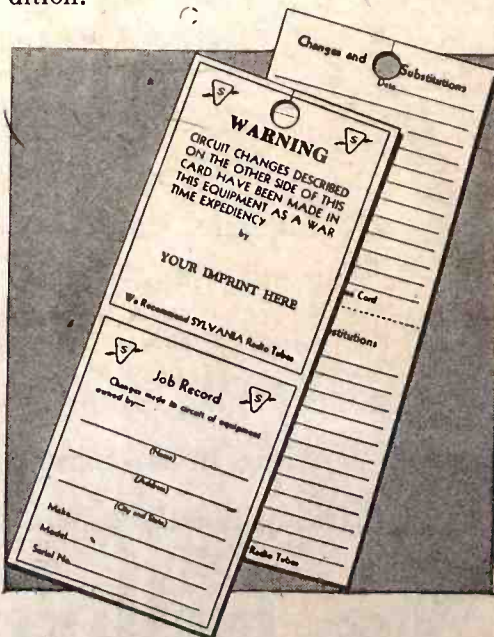

SYLVANIA  **ELECTRIC**

PRODUCTS INC.
Radio Division • Emporium, Pa.

MAKERS OF FLUORESCENT LAMPS, FIXTURES, ACCESSORIES, INCANDESCENT LAMPS, RADIO TUBES, CATHODE RAY TUBES, ELECTRONIC DEVICES

SPRAYBERRY RADIO TRAINING

Gives you Both



FULL RADIO SET SUPPLIED FOR SHOP PRACTICE!

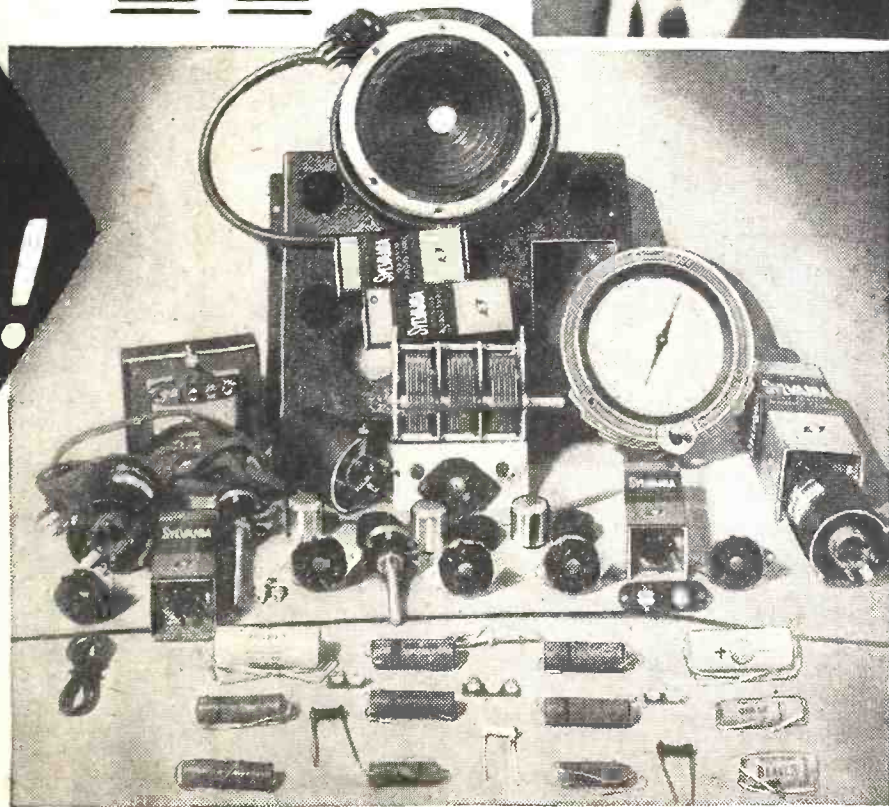

HERE'S THE ONE PRACTICAL WAY TO TRAIN FOR BIG EARNINGS AHEAD IN RADIO-ELECTRONICS & TELEVISION

The offer I make you here is the opportunity of a lifetime. It's your big chance to get ready for a wonderful future in the swiftly expanding field of Radio-Electronics INCLUDING Radio, Television, Frequency Modulation and Industrial Electronics. Be wise! NOW'S the time to start. No previous experience is necessary. The Sprayberry Course starts right at the beginning of Radio. You can't get lost. It gets the various subjects across in such a clear, simple way that you understand and remember.

I'll Show You a New, Fast Way to Test Radio Sets Without Manufactured Equipment

The very same Radio Parts I supply with your course for gaining pre-experience in Radio Repair work may be adapted through an exclusive Sprayberry wiring procedure to serve for complete, fast, accurate Radio Receiver trouble-shooting. Thus under Sprayberry methods you do not have one cent of outlay for manufactured Test Equipment which is not only expensive but scarce.

Prepares You For a Business of Your Own or Good Radio Jobs . . . Civilian or Military

My training will give you the broad, fundamental principles so necessary as a background no matter which branch of Radio you wish to specialize in. I make it easy for you to learn Radio Set Repair and Installation Work. I teach you how to install and repair Electronic Equipment. If you enter the Army, Navy or Marines, my training will help you win higher rating and better pay.

JUST OUT! FREE! HOW TO READ RADIO DIAGRAMS AND SYMBOLS

... a valuable new book which explains in simple, non-technical English how to read and understand any Radio Set Diagram. Provides the quick key to analyzing any Radio circuit. Includes translations of all Radio symbols. Send for this FREE book now while supply lasts and along with it I will send you another big FREE book describing my Radio-Electronic training.



GET FREE BOOKS

SPRAYBERRY ACADEMY OF RADIO
F. L. Sprayberry, Pres.
Box 500TN
Pueblo, Colorado

Please rush my FREE copies of "HOW TO MAKE MONEY IN RADIO, ELECTRONICS and TELEVISION," and "HOW TO READ RADIO DIAGRAMS and SYMBOLS."

Name Age

Address

City State

Tear off this coupon, mail in envelope or paste on penny postcard.

SPRAGUE TRADING POST

A FREE Buy-Exchange-Sell Service for Radio Men



...from all of us to all of you!

To all our friends, old and new; to those in the armed forces; to all who have entered war work; and to those still on the job at the old stands...

Our best wishes for the 1944 Yuletide and our sincere hope that the year 1945 will see the dawn of a peaceful, better, happier world.

SPRAGUE PRODUCTS CO.

FOR SALE—Series 900 Precision dynamic electrometer; E-200 Precision signal generator; No. 89 Supreme tube checker; No. 330 multi-frequency R-F oscillator. J. Ralph McCook, 351 S. Main St., Lewistown, Pa.

FOR SALE—RCA No. 154 beat frequency oscillator, new six months ago, perfect condition, \$50. Fox Sound Equipment Co., 435 So. 5th St., Richmond, Ind.

WANTED BY SOLDIER OVERSEAS—EC-6 Echophone portable radio. Will pay full list price. Write my mother, Mrs. F. W. Peck, 1716 West Lake St., Minneapolis 8, Minn.

FOR SALE—Webber tube tester, 12 sockets, provisions for more, neon short test, \$18. Charlie's Sport Shop, Kankakee, Ill.

TUBES FOR SALE—Over 300 including 2A3, 2A5, 2A7, 6SF5, 6A8, 5Y3, 11A5, 12Q7, 12SK7, 1A5, 35, 26, 57, 58, 77, 84, 85, 6SK7, 523, 5V4, 6K7, 6K8, 12SF5, 1LH4, etc. Write for list. Want oscillator and signal generator. Frank's Radio Service, 70 Summer St., Stamford, Conn.

TEST EQUIPMENT WANTED—All kinds. We have a few hard-to-get tubes and parts to trade or sell. Send us your needs and list of what you have. All inquiries answered. Len's Radio Service, 7405 Superior Ave., Cleveland 3, Ohio.

FOR SALE OR TRADE—6D6, 2A4, 80 tubes, large 8-gang var. condenser with dial, pointer and shaft. Want small soldering iron, 60 watt, also low-priced pick-up. Morton Bardfield, 4 Brinsley St., Dorchester 21, Mass.

WANTED—1A5, 1A7, 1C5, 1H5, 1N5, 1P5, 1Q5, G or GT, also late tube checker, battery operated, with instructions. G. W. Selby, Columbia, N. C.

FOR SALE—Beginner's radio kits complete ready to assemble, also tubes: 1H5GT, 35Z5, 25L6, 50L8, 12SQ7GT and many others, also auto radios, parts, etc. Write for list. Southern Radio Shop, 1310 24th St., Newport News, Va.

FOR SALE—Stewart Warner magic keyboard remote control push button unit. Can be used with 6 models or more. Also RCA remote control push button unit. Frank C. Guest, 27 Parkinson Ave., R.D. No. 5, Trenton, N. J.

WANTED—Thordarson output transformer T 90513 or U.T.C. LS55. State price. Bailey Radio Shoppe, 2238 Bailey Ave., Buffalo, N. Y.

WANTED—Rider's Manuals complete or in part; a-c ammeter 0-3, or 0-5; oscilloscope; output meter; tubes (popular numbers only). State all details fully. D. T. Edgar, 6519 34th Ave., N.W., Seattle 7, Wash.

WANTED—Vacuum tube tester and signal generator, also Rider's Manuals. Bernard De Primo, 178 East Ave., Norwalk, Conn.

FOR SALE—Dayrad multi-frequency R-F oscillator No. 330 in excellent condition, \$35 complete. James O. Robinson, 508 Franklin St., Selma, Ala.

WANTED—456 K.C. B.F.O. transformer. Cash or will trade parts. M. E. Wolff, 311 So. 8th St., Goshen, Indiana.

FOR SALE OR TRADE—Have 1R5, 1C5, 1Q5, and 80 tubes. Want used 1 1/2-80 volt battery sets. W. N. Gravlee & Son, Kennedy, Alabama.

WILL SWAP 35mm and 16mm movie projectors; Midas 3 1/2mm camera-projector; several radios; RCA Radio Service Course; Pipe stock and die; QST and other magazines; meters; rotary converter. Want lighting plant; gas refrigerator, power cultivator, 35mm still camera, etc. Joseph Leeb, 1380 Merriam Ave., Bronx, New York 52, N. Y.

FOR SALE—Straight key, Signal Elec. Co. M-100, \$1; Vibroplex bug "Original", 2 extra wts. with cord, like new, \$18; Nathaniel Baldwin phones Type C, \$6; Power supply using 80 tube (5Y-71A; 2 1/2V-27A; 1 1/2V-26A; 45V-90V-180V) taps with tube, \$2. Lyle Sovay, 231 Langdon St., Toledo 9, Ohio.

FOR SALE OR RENT—Completely equipped radio service department and appliance store with 5-room living quarters. On main street of city of 15,000. Write, Gregg Radio & Appliance Co., Fremont, Ohio.

FOR SALE—Instruments, tubes, parts. Send stamp for list. John Trowbridge, 7930 Parnell St., Chicago 20, Ill.

URGENTLY NEEDED FOR CASH—Test equipment of all kinds. B. M. Meadows, 1973 Brackland St., Jacksonville 6, Fla.

WANTED—Webster-Rauland record changer W-1291 or one very similar. Must be in A-1 condition, with or without case. Pete Herring, Rgs. 39545, P.O. Box 97, McAlester, Okla.

FOR SALE—RCA phonograph motor, turntable and pickup 110v, 60 cycle, \$5. Seth's Radio Service, 100 South Street, Milltown, Maine.

WILL SWAP—Webster Dynamotor E-2 input 6v 15 amps., output 350v 150 amps. Want RCA automatic record changer or other quality make or what have you? Thomas T. Allen, 1528 North St., Flint 4, Mich.

FOR SALE—Two coils, ranges 16-36 meters and 62-115 meters (6-prong plug-in type). One Bud MC908 midget 140 mmfd. var. condenser, heavily insulated, suitable for S-W receiver; Hoyt No. 531 d-c ammeter, 50-0-50; No. 42 ammeter 30-0-30, all new. S. Nelson, % 6229 Angus Drive, Vancouver, B.C., Canada

FOR SALE—Echophone EC-1 complete plus extra set of tubes, \$27.50. Walter F. Allgeyer, Box 192, Newark, N. J.

WANTED—An RCA-Rider Chanalyst in "like new" condition, preferably in Canada. Radio Electric Service, Longenburg, Sask., Canada.

FOR SALE—Triplet tube checker, No. 1210A, in A-1 condition with adaptors and charts, \$15; Superior sig. generator, T37, 5 bands, needs slight repair, \$15. Debolt's Radio Service, South State Road, Gallon, Ohio.

FOR SALE—New Stancor deluxe A pack, \$50; two Philco auto radios, one for 1936-37 Nash, one for 1936 or '37 Chrysler, Plymouth, Dodge or Desoto, \$30 ea., in good condition. Paul Capito, 637 W. 21 St., Erie, Pa.

FOR SALE—Supreme No. 541 V-O-M in good condition. Ramon Walker, 616 So. 2nd St., Union City, Tenn.

WANTED—Operating instructions for 197 Jewell Radio Analyzer. Clifford E. Jenkins, Jr., 171 Homestead Ave., Holyoke, Mass.

WANTED—All-wave sig. generator; condenser checker; tube reproprocessor. Must be in perfect condition. Radiodell Radionics Labs., 1112 El Carson St., San Antonio 8, Texas.

FOR SALE—Many hard-to-get radio items. What do you need? R. W. Wood, 10950 Longview Ave., Detroit 5, Mich.

FOR SALE OR TRADE—Speakers, transformers, d-c motors (1/30th and 1/50th h.p.), condensers, electrical books, etc. Want radio test eqpt. or what have you? Benjamin Brooks, 3111 West Columbia Ave., Philadelphia 21, Pa.

WANTED—Supreme No. 560-A Veedolyzer, No. 561 signal generator, and No. 589 or No. 590 with a 9" meter. Leonard V. Jeffries, 1726 Prentiss Ave., Portsmouth, Va.

FOR SALE OR TRADE—Muter Res. Bridge No. 1200 like new; Weston No. 361 0-1 mill, 1000 ohms per volt meter with universal scale, perfect; Weston output meter. Want condenser checker and 12, 35, 50 volt series tubes. Louis Wolanin, 5415 S. Tripp Ave., Chicago 32, Ill.

WANTED—Superior 1130-8 signal generator, Channel Analyzer, 1250 multitester, 1280 set tester, also condenser tester. Hover Radio & Camera Shop, Box 98, Santee, Calif.

WILL TRADE R.C.P. No. 445 V-O-M, many scarce tubes, two twin 40 fluorescent ballasts. Want P-M converter or Melsner or Carran P-M tuning assembly with I-F transformers. Fred Rouse, 5 Euclid Ave., Cortland, N. Y.

URGENTLY NEEDED—Complete set Rider's manuals. Also want RCA-Rider chanalyst. Cash. Louis Hopper, 8308 S.E. 13th Ave., Portland 2, Oregon.

WILL SWAP 5-tube Eada, 205 series receiver. Want all-wave signal generator, signal tracer, and other test equipment. What have you? Clinton C. Carroll, Shrewsbury, W. Va.

WILL TRADE N.R.I. code course complete with instruments and tapes for condenser checker or what have you? Also have assortment of books on basic radio, etc. DeLuxe Radio Service, Columbus, Miss.

FOR SALE—Howard 610 power pack, \$15; gonemotor 12v/500v, \$12; signal shifter, \$25. J. E. Thompson, 1440 West 47th St., Chicago 9, Ill.

WANTED—Philco or Triplet tube tester, also 25A7G tubes. John A. Sulick, 1252 Brockley Ave., Lakewood 7, Ohio.

WANTED—Test eqpt. of any type. Signal generator urgently needed. Cash or will trade parts. What have you? Cpl. Gerald R. Fuller, Section B, Bks. 2407, Truax Field, Madison, Wis.

YOUR OWN AD RUN FREE!

Send us your Sprague Trading Post advertisement today. We'll be glad to run it free as part of our special wartime advertising service to the radio profession. **WRITE CAREFULLY OR PRINT.** Hold it to 40 words or less. Different Trading Post ads appear regularly in **RADIO RETAILING-TODAY, RADIO SERVICE-DEALER, SERVICE, RADIO NEWS and RADIO-CRAFT.** Please do not specify any particular magazine for your ad. We'll run it in the first available issue that is going to press. Sprague, of course, reserves the right to reject ads which, in our opinion, do not fit in with the spirit of this service.



SPRAGUE PRODUCTS CO., DEPT. RC-15, North Adams, Mass.
(Jobbing distributing organization of products manufactured by SPRAGUE ELECTRIC COMPANY)

SPRAGUE CONDENSERS

* KOOLOHM RESISTORS

Obviously, Sprague cannot assume any responsibility, or guarantee goods, services, etc., which might be exchanged through the above advertisements

*TRADEMARK REG. U.S. PAT. OFF.

For Good Jobs TODAY...
TOMORROW...LEARN

RADIO ELECTRONICS DeFOREST'S A-B-C WAY!

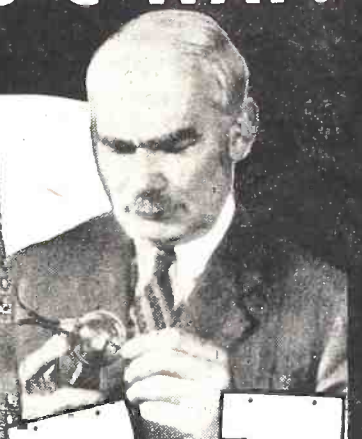
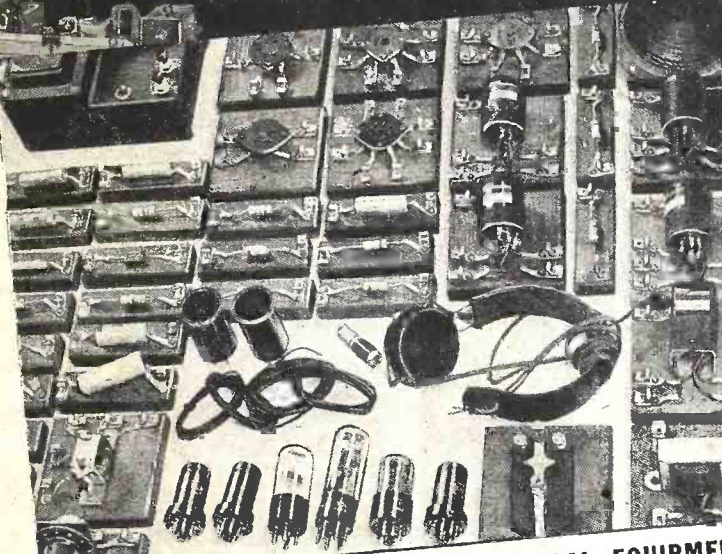
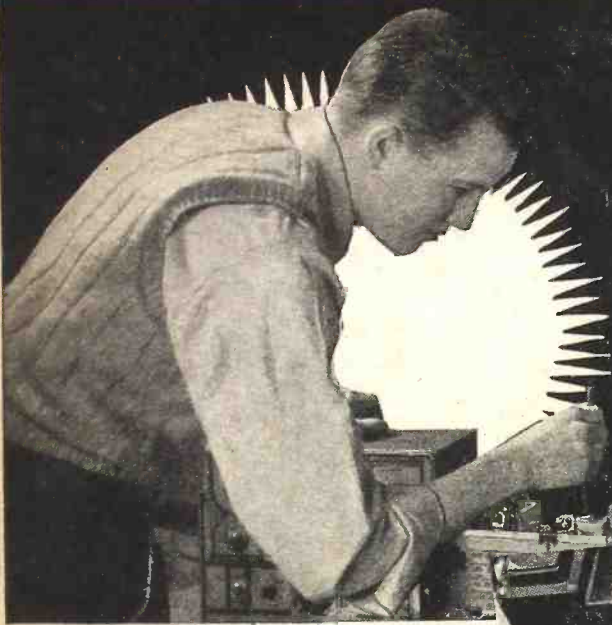

THE fast-moving Opportunity Field of Radio-Electronics needs many trained men! Let DeFOREST'S show you how to get ready to take advantage of the breaks—the good jobs—the satisfying pay checks of today—and the bright postwar opportunities of tomorrow. Write for DeFOREST'S big, free book—"VICTORY FOR YOU" and colorful kit supplement.

Consider Radio's Many Fields

See how you may cash in on a vast field that includes F.M. Radio, Communication Radio, Electronics, Broadcast Radio, Motion Picture Sound, Radio Sales and Service—or a Radio business of your own.

Start a Business of Your Own

See how DeFOREST'S has helped many get their start in Radio-Electronics—helped them to good pay jobs in one of our most promising industries—others to preferred military classifications with higher ratings, better pay. Helped others to full or part time sales and service businesses of their own.

Employment Service!

DeFOREST'S also provides an effective EMPLOYMENT SERVICE which has long-established contacts with many employers who use DeFOREST'S trained Radio-Electronic men.

Mail the coupon Now—Today!

See how DeFOREST'S can help YOU get started toward this fascinating work by means of its effective "A-B-C" Training Method—in your spare time.

VETERANS: Check coupon below for special information.

A "LEARN-BY-DOING" FROM PRACTICAL EQUIPMENT

Make 133 interesting Radio-Electronic experiments at home—from 8 BIG KITS of Radio parts and assemblies. Quickly build Radio Receiving Circuits that operate... a Light Beam Transmitter... Wireless Microphone... Radio Telephone... "Electric Eye" Devices. Scores of other fascinating projects.

B GET INTERESTING, LOOSE-LEAF LESSONS—

90 modern, well-illustrated loose-leaf lessons, prepared under the supervision of one of the world's foremost Radio authorities, Dr. Lee DeForest, often called "The father of Radio!"

The Billion Dollar Radio-Electronic Industry, with its Manufacturing, Servicing, Broadcasting, Communications, and many other promising fields, invites your careful consideration. See how DeFOREST'S helps you prepare for a good pay job, or a business of your own in one of America's most promising, interesting fields.

DeFOREST'S TRAINING INCLUDES INSTRUCTION IN MOTION PICTURE SOUND EQUIPMENT, FM RADIO AND TELEVISION

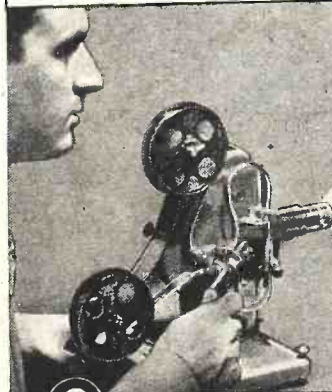

See Radio Circuits in Action—Electrons on the March—with this genuine DeVRY Projector

C USE "LEARN-BY-SEEING" MOVIES

with a genuine DeVRY 16mm. Movie Projector and Films to help you learn Radio faster... easier. See hidden Radio action come to life! Radio waves in motion—*Electrons on the march*...



READ WHAT THESE MEN SAY ABOUT DeFOREST'S TRAINING

"I have obtained employment with the... Mfg. Company. They speak highly of DeForest's students and state they have had excellent results with your men whom they have employed."
Clifford Taylor, Mass.

"As a result of DeForest's Training, I am doing very well. If my income doesn't range between \$50.00 and \$75.00 per week, I figure something is wrong."
Lyle Rielly, Wisconsin

"But the credit must go to you and your employment service for placing me in this job when I really needed one. I shall always be grateful for the help and guidance given me by you and DeForest's Training. Thanks a million."
Earl Eichelberger, Illinois.

"I cannot impress too strongly on anyone who may be considering taking your course the value of both the training and the employment service that goes with it. This service is not merely an empty promise, but a truly conscientious effort that continues until its job of preparing you is done."
Philip Cummins, New Jersey.

"I am amazed at the many subjects I have learned with DeForest's. I also want to praise your motion picture lessons. It is truly amazing, how well the action of electricity is brought out. I feel safe in saying that no book could ever establish effectively those principles and actions so well in my mind."
Yale Schorr, Texas.

E. B. DeVry, President
DeFOREST'S TRAINING, INC.
2535-41 N. Ashland Ave., Dept. BRC-1
Chicago 14, Illinois, U.S.A.

Please send me your "VICTORY FOR YOU" book and KIT FOLDER, FREE.

Name..... Age.....
Address.....
City..... State.....

If under 16, check here for special information.
 If a veteran of World War II, check here.

DeFOREST'S TRAINING, INC.
CHICAGO 14, ILLINOIS

American OUT IN FRONT!

Whether it's the philharmonic, oratory, news, public address, sportscast or commercial, the quality of the program that goes through depends **first** on the microphone **OUT IN FRONT!**

D5

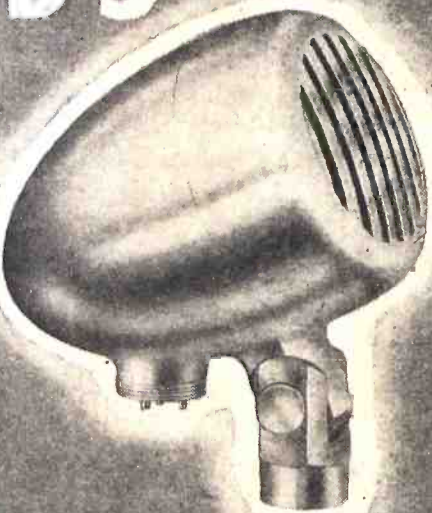

D5 DYNAMIC—An ideal microphone for general use. Due to its versatility and dependability. Microphone contour and diaphragm protective grille designed to minimize wind noise and sound field distortion. Recommended for close talking as well as distant sound source pick-up.

There it stands, unattended, with the whole show going on. It just has to be dependable. It just has to have full range for the job.

D3

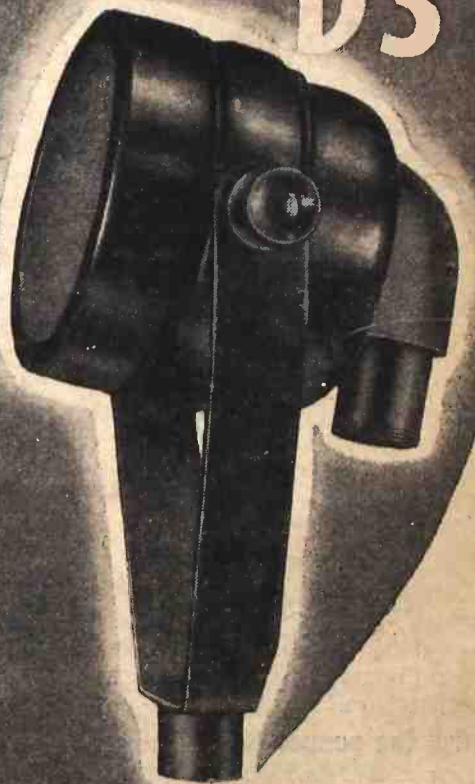

D3 DYNAMIC—Recommended for those microphone applications where high fidelity (uniform response from 50 to 10,000 cps) is of prime importance. Attention to detail in design and construction of each microphone insures stable operation and optimum performance for all types of audio pick-up.

D9A

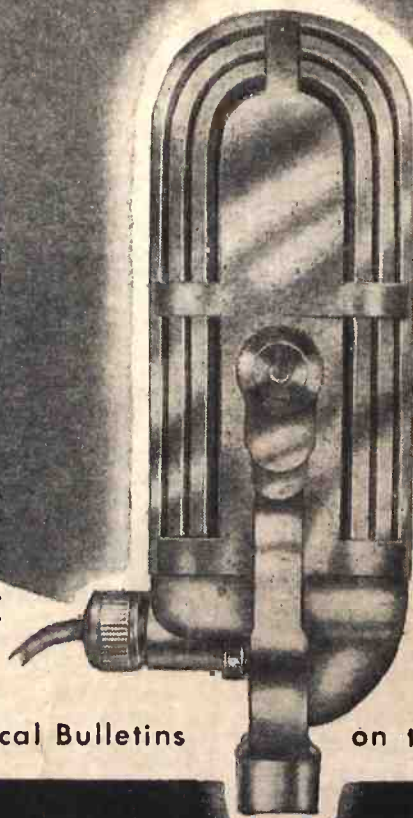

D9A UNIDIRECTIONAL DYNAMIC—A pressure-velocity combination microphone, will pick-up from front only, broad frequency response and high output, should fill the majority of requirements. Especially recommended for indoor use due to feed-back reduction and elimination of extraneous pick-up.

Write for Comprehensive Technical Bulletins

on these and other American Microphones.

American MICROPHONE CO.

1915 So. Western Avenue, Los Angeles 7, California



KEEP UP WITH RADIO TELEVISION and ALLIED ELECTRONICS

Get in on the new developments in the fast expanding Radio Industry. Take your place in the field of Television. Make more money as a Modern Service Expert. Own and operate Your Own Business. Learn the latest Trade Secrets and Short Cuts through

SHOP METHOD HOME TRAINING

Don't waste time! Radio, F.M., Video (television), and the whole field of Electronics is changing fast. If you are in the radio business now you know what you are up against—new methods, new techniques, new equipment. You know how fast the field is growing. Today you must solve NEW problems in servicing and repairing F.M. receivers. Tomorrow there will be thousands upon thousands of Television Receivers to handle. Right after the war science promises NEW Electronic devices for household, factory and business. **ALL THIS MEANS NEW OPPORTUNITY FOR YOU IF YOU ARE READY.** The thing to do is to GET READY right now. Find out about the marvelous new method of preparation—SHOP METHOD HOME TRAINING. Fill out and send in the coupon now.

KEEP IN STEP WITH SHOP PROGRESS

Here IS the truly modern system of training. It matches the RAPID PROGRESS CONSTANTLY BEING MADE in Radio, Television and Electronics. It is up to date in every way because it comes right from the busy radio training shops of National Schools where experiments and developments are being carried on—where discoveries are being made all the time. It is based on real shop methods—on the handling of real shop jobs. Only National can offer you SHOP METHOD HOME TRAINING because only National has the big busy shops to develop this method. And it is time tested too. National Schools has been training men for industry, for government, for business for more than a third of a century. In essence you get at home—in your free time—the very same kind of instruction that has helped thousands upon thousands of ambitious men to more pay and greater opportunity—that has set thousands of men up in business with little

or no capital. You owe it to yourself to read the book, "Your Future in Radionics"—sent to you FREE if you fill out and mail the coupon.

MAKE EXTRA MONEY RIGHT FROM THE START

You get ahead fast with National Training. Many beginners make good money on the side fixing radios and doing service work. You can turn your knowledge into cash after the first few lessons. Progress is rapid. You can actually SEE YOURSELF GET AHEAD, because the National Shop Method is so sound and practical.

Now, right now, is the time to grasp the opportunity of today—a successful career for tomorrow. Get into the big money, rapid advancement, a position of importance. A BUSINESS OF YOUR OWN. Radio, television and the whole field of electronics invites you. The industry is crying for trained men everywhere. A rapidly expanding industry—probably the greatest in history—holds out the promise of a rich future—prosperous security.

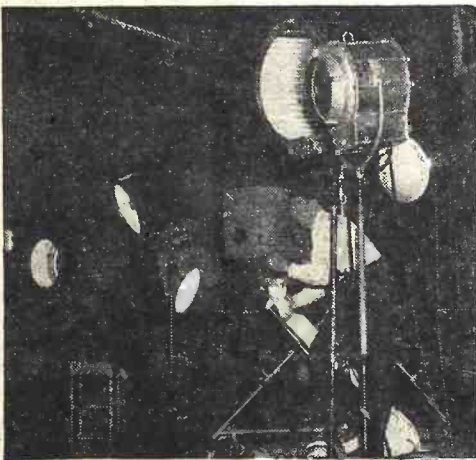

Get the Real Experience Before You Tackle a Job

Walk into a brand new job and go to work with assurance—the assurance that comes with knowing how—that comes with handling the tools—with working with and operating actual electronic equipment sent to you from the laboratories and shops of National Schools. There's nothing to equal learning by doing. In your National training you build real sets—a super-heterodyne receiver, a signal generator—literally scores of various electronic devices with your National equipment. **Learn basic principles—FIRST THINGS FIRST.** Get your knowledge and experience first hand under the personal guidance of seasoned, practical National instructors working personally with you. You know the very how and why of Radio—Television, Electronics.

Not only do you gain marvelous actual experience by this method of learning but you have valuable equipment you will use on the job in the practice of your profession as an electronics expert. Mail the coupon and learn what this means to you.

After the War What?

Face realities now! Is the job you're doing going to last? What is its future and yours? How are you going to meet conditions when the world returns to civilian production? There's no use in fooling yourself. Radio is a BIG, SOUND, WELL ESTABLISHED BUSINESS.

There are millions of sets in the Country that need reconditioning right now. There is a big demand for millions more that have to be built—largely by trained men. F.M. is here to stay. **BUT RADIO IS ONLY ONE FIELD OF ELECTRONICS.** Television is sure to come. One can only guess the size of this opportunity. Sets must be built, installed, serviced and repaired. Who's going to do it? Make up your mind that you are—and at a big profit—for years to come.

What about facsimile? That has been proved and approved for use by newspapers, communication systems—industry as a whole. And the great new field of industrial electronics? It is established—here to stay. **IT NEEDS MEN—RIGHT NOW** and more men next year, next month, tomorrow! When you have up your uniform—when your war job folds up, will you step out proudly into a new field—an essential established industry?—perhaps into a business of your own?

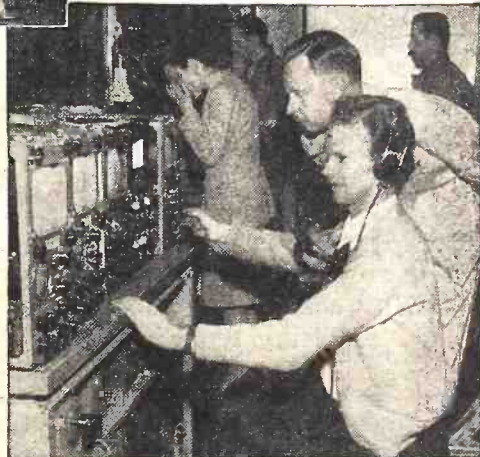

The above pictures were made in and around a modern television studio. Think what new opportunity is open to you in this great new field if you are ready for it. Prepare now. National training includes a good foundation in Television and F.M. Get the facts. Send the Coupon.

All This Modern Electronic Equipment and More Comes to You as Part of Your National Course



Get This FREE LESSON



NATIONAL TRAINED MEN NOW MAKING THE BEST MONEY IN HISTORY

The real value of National training shows up in the quick progress our men make on the job. Joe Grumich of Lake Hiawatha, N. J., turned down a job most men would welcome. He writes: "My latest offer was \$5,800.00 as radio photo engineer, but I am doing well where I am now engaged. I am deeply indebted to National." Ely Berkman, now on Station WOR, told us: "My salary has been boosted considerably and at the present time I am making over \$3,000.00 per year, thanks to National Training." And from the far-off Hawaiian Islands, Wallace Choi sends this: "I am averaging \$325.00 a month. I will say that I honestly owe all this to the excellent training I had at National."

National is proud of the progress graduates are making all over the world. Read about their records yourself in the books we send you FREE.

Get a FREE lesson from National. Study it over at your convenience. See for yourself how thorough, how sound and how practical—yet how amazingly easy it is to learn and understand. **NO SALESMAN WILL CALL ON YOU FROM NATIONAL SCHOOLS.** National points out the opportunity—offers you the training and experience, prepares you for greater things in life. But it is up to you to act for yourself. And the first step is to fill out the Coupon and mail it. Get FREE lesson, the big Radio Book, and then decide.

NATIONAL SCHOOLS

LOS ANGELES 37, CALIFORNIA EST. 1905



MAIL OPPORTUNITY COUPON FOR QUICK ACTION

National Schools, Dept. I-RC
4000 South Figueroa Street, Los Angeles 37, California

(Mail in envelope or paste on penny post card)

Mail me FREE the two books mentioned in your ad including a sample lesson of your course. I understand no salesman will call on me.

NAME AGE.....
ADDRESS
CITY STATE

Include your zone number



FINEST PICTURE QUALITY IN BLACK AND WHITE AND IN FULL COLOR!

Sharper, more brilliant pictures than ever before possible are now a reality with Federal's new broad-band television technique . . .

In a revolutionary contribution to the television art, Federal's system permits combining *sight and sound* on one carrier frequency . . .

For the broadcaster—a single transmitter, and consequently, lower first cost, lower power consumption, less space requirement, and fewer high power tubes . . .

For the television audience — a

simpler, less expensive receiver, more compact and efficient, and requiring fewer tubes.

This great forward stride is the logical outcome of Federal's long list of achievements in the field and the contribution of Federal's engineers to the development of the "Micro-ray" more than a decade ago . . . the forerunner of modern television technique.

And as a result . . . Federal has been selected by the Columbia Broadcasting System for the construction

of its new television transmitter atop the Chrysler Tower in New York.

Federal's modern television technique will also be reflected in an equally advanced Federal television receiver for the home . . . producing the finest picture quality.

Federal has the experience, the facilities, the technique, needed to build television equipment for any broadcasting requirement. For the best in television — see Federal first.



Federal Telephone and Radio Corporation



Newark 1, N. J.

Post-War Servicing Opportunities

. . . . Industrial electronic maintenance and servicing offers the radioman a profitable new field which will doubtless eclipse broadcast receiver servicing in the post-war world

HUGO GERNSBACK

THE EUROPEAN war which is now drawing to a close, will return many thousands of radiomen from our armed forces. Most of them will go into the electronic and radio servicing field. We have many indications on this. During the past year hundreds of letters received by RADIO-CRAFT from servicemen indicate that radio servicing will be one of the favorite occupations of former men of the armed forces.

There are also thousands of ex-radioservice men who were in this business before they entered the armed forces. These, too, in large numbers, will also wish to get back into their former line of work.

It is safe to predict that for many years to come, after hostilities cease, radio servicing will be profitable to those who give *real* service and are expert in radio.

For some time to come, in the very nature of things, not everybody will rush to a radio store trying to buy a new radio receiver. A recent survey just to hand, shows, surprisingly, that other home appliances will be much more in demand than new radios. The following tabulation shows this:

Type of article	Number of persons who intend to purchase "as soon as available"
Washing machines	4,300,000
Electric irons	4,000,000
Refrigerators	3,800,000
Electric cook stoves	3,200,000
Toasters	3,200,000
HOME RADIOS	2,700,000
Vacuum cleaners	2,400,000
Sewing machines	2,300,000
Fans	1,500,000

The reason for this, as the survey explains, is that the great publicity which radio manufacturers have given to post-war radio sets has no doubt caught the imagination of the American public. That means that people will not be so anxious to exchange their present sets for a 1942 model even if it is brand new. They feel that they will wish to wait for new type FM receivers, television combinations and others.

To the serviceman this is a grand opportunity in servicing the old set which John Q. Public wishes to

hang on to until the newer improved sets come out. It also means that from one to two years after the European war has ceased, the old sets will need a tremendous amount of radio servicing and overhauling.

This is a real chance for the serviceman, because he will no doubt be much better paid in the post-war period than he was prior to 1942. He will have steady work, too, for a long time and an abundance of jobs.

Radio servicing will, in many ways, be far different than it was in 1942. During the past years there has been tremendous progress in radio and particularly in electronics. *There will be many new types of jobs during the next few years which never existed before.* Many of our plants have taken to industrial electronics and there are few of them today that do not have some kind of electronic appliance. Sometimes these plants are in smaller cities or isolated in such a manner that the electronic manufacturer who originally supplied the device is handicapped in doing a quick repair job. That means that if the future radio serviceman has a good grounding in industrial electronics, he will no doubt be called in to do an electronic servicing job. A good tip to the future serviceman is to make himself acquainted with the plant managers in his locality so that if anything goes wrong he or the superintendent will know for whom to send in case anything happens to the electronic devices. The reason for this is that most industries—except the very large plants—will not have enough work to keep an electronic engineer on the job all the time, but they will need a good maintenance man. If they know that the outside independent serviceman can be relied upon, the job will go to him, or to the man who is best qualified to do this intricate work justice.

It must be understood that all these ripe and profitable plums will not fall into every serviceman's lap. That is not the way modern business works! The old-time radio serviceman certainly was not qualified for this important type of work. He will have to take on a complete up-to-date *(Continued on page 253)*

Radio Thirty-Five Years Ago

In Gernsback Publications

From the January, 1910, issue of MODERN ELECTRICS:
 Dr. Korn's Apparatus (Telephotography), by A. C. Marlowe.
 A Muffled Spark Gap, by H. W. Secor.
 New Tuning Arrangement, by J. A. Fleming.
 Metropolitan Tower Radiophone.
 New Rectifier, by the Paris Correspondent.
 Marconi Wave Meter.
 New Condenser for High Tension, by the Paris Correspondent. The Construction of a Hot Wire Ammeter.
 The Construction of a Sending Con-

HUGO GERNSBACK Founder	
Modern Electrics	1908
Electrical Experimenter	1913
Radio News	1919
Science & Invention	1920
Radio-Craft	1929
Short-Wave Craft	1930
Wireless Association of America	1938

denser, by Frederick Re Qua.
 How to Make an Improved Silicon Detector, by Charles W. Gale.
 The Roberts Wireless Bill, proposing a

Some of the larger libraries in the country still have copies of Modern Electronics on file for interested readers.

National Wireless Telegraph Board.)
 How to Make a Universal Detector, by E. R. Willard.
 A Unique Transmitting Helix, by Frank C. Perkins.
 Brass Bed as Aerial.
 How to Build an Efficient Vibrator, by "A.S.N."
 New Loud Speaking Telephone.
 Hen Wireless Effective.
 A Simple Detector, by Clyde Smith.
 Tuning Coil Slider.
 A Simple Rectifier.
 Combination Detector.
 Novel Wireless.



Radio-Electronics

Items Interesting

ALL-ELECTRONIC methods for drying penicillin were announced last month by Dr. George H. Brown, of the Radio Corporation of America. A single unit operating on the new system can in one month produce more penicillin than did the combined output of all plants in the United States during a 30-day period six months ago.

Readers of *Radio-Craft* will recall that Dr. Brown had previously constructed an electronic dehydrator which would carry out one step of the drying process with a great saving in time and apparatus. (*Radio-Craft*, September, 1944.) Success with this equipment led to application of electronic heating to the final phase of production, that of reducing the concentrated penicillin solution to a dry state in ampuls or vials ready for shipment.

Since ordinary heat methods destroy the effectiveness of penicillin, plants under WPB control have been achieving bulk-reduction of penicillin solution through the use of dry ice and a high vacuum at below freezing temperatures. The RCA scientists discovered that in a moderate vacuum they could boil and evaporate the solution at 50 degrees Fahrenheit, a temperature that does no harm to the drug during its brief period of exposure.

When the vacuum was applied to the 20 cc. bottles containing 1 cc. of concentrated penicillin solution, the liquid foamed and much of it was lost. This obstacle appeared unsurmountable for awhile. Then it occurred to the scientists that revolving the bottles at a speed high enough to cause the liquid to form a thin layer around the walls of the bottle might solve the problem which had hitherto prevented the high-speed production of penicillin.

Dr. Brown and his associates designed such a rotator and were rewarded by the discovery that it not only worked but the thin layer of liquid would evaporate much faster than anticipated.

PRESIDENT of the Institute of Radio Engineers for 1945 is Dr. William L. Everitt, one of America's foremost authorities on radio and electronics, it was announced last month by the IRE Board of Directors.

Dr. Everitt, a Fellow and a Director of the Institute, is the author of several books and numerous technical magazine articles on subjects relating to radio engineering, electronics, and communications. His experience includes research and consulting-engineering work with the American Telephone and Telegraph Company and various manufacturing organizations and professorships at several American universities. He is also the inventor of a number of radio and electronic devices.

The election of Dr. Hendrik J. Van der Bijl of Johannesburg, Union of South Africa, as vice-president was announced simultaneously. Dr. Van der Bijl is a Fellow of the Institute from 1928, and is internationally known for his work on vacuum tubes.

PRODUCTION of 9,100,000 miniature receiving tubes for the Army, Navy and Lend-Lease in the first quarter of 1945 will be necessary if present requirements are to be met, officials of the Radio and Radar Division, War Production Board, announced last month.

Current production of miniature radio receiving tubes, at approximately 2,600,000 tubes per month, indicates a serious shortage of this type of tube used extensively by both the Army and Navy, members of the Radio Receiver Vacuum Tube Industry Advisory Committee were told at a meeting, November 2, 1944. The total shortage was placed at 250,000 tubes per month, while monthly production of battery type miniature tubes was said to be 200,000 a month short of essential requirements, Radio and Radar officials reported.

"MOST IMPORTANT electronic device of the war" is the term applied by some to the electronic computing gunsight, news of which has been released by permission of the War Department.

Details of the sight's construction were revealed last month by Erwin Hale, engineer of the Fairchild Camera and Instrument Corporation, manufacturers of the instrument. Speaking before the national fall meeting of the Institute of the Aeronautical sciences at Dayton, Ohio, he described the sight as "an electrical brain" and stated that it "has provided a material advance" in the art of aircraft gunsighting. Hale, who is in charge of airborne fire control instruments for the Fairchild Corporation, is the co-inventor, with Irving Doyle, of the electronic weapon, and the restrained language used may have been due to the inventor's modesty.

With the new gunsight, known as the K-8, the effective range of .50-calibre machine guns has been extended to more than 1,000 yards; without it the maximum range at which hits might be expected has been only 400 to 600 yards, and even then the probability of obtaining a hit has not been very high, he told the Institute.

All the computation is done electrically, and the final voltage representing the desired offset between the line of sight and the gun is then sent to an electronic servo system to provide the desired offset.

SECRECY on the Air Force's fog- and cloud-piercing electronic eye (previously referred to as the "ground detector") has been partially lifted. Newspaper reports last month confirmed the widespread opinion that the device was radar-operated.

The radar eye—affectionately called "Mickey" by airplane crews—actually throws a rough picture of the ground beneath on the instrument screen. "Visibility" is in no way affected by clouds, fog or man-made smoke-screens below.

The image on the screen is excellent in outline, particularly when a coast is involved. (This was proved beyond doubt on D-day in southern France, Aug. 15, when magnificent results were achieved.) But for specific targets, "Mickey" is not yet a match for visual bombings and ought not to be regarded as such.

Heating chamber used in the all-electronic penicillin drying system. Made of a port-hole frame and glass, its nautical origin may plainly be seen in the photograph. At center, Dr. George H. Brown, the inventor.



Monthly Review

to the Technician

TELEVISION COSTS were the subject of important testimony before the FCC's recent allocations hearing. James D. McLean, General Electric television sales manager, backed up earlier testimony of L. A. Weiss (*Radio-Craft*, December) that the expense would confine primary television stations to the larger cities.

McLean estimated initial expense for a station at \$140,000 to \$165,000, with the annual operating cost \$231,000. Satellite stations would entail an initial cost of from \$48,000 to \$58,000, he said, rising to from \$66,000 to \$69,000 if film-origination facilities are included. Operating cost unattended he estimated at \$15,000, attended \$45,000 and attended with film facilities \$65,000.

His cost estimates, McLean said, are based upon the cost of apparatus and technical operating costs of television stations providing program service in accordance with RTPB standards, and upon GE's pre-war prices.

G. R. Town, Stromberg-Carlson engineering manager, spoke briefly on receiving set costs, estimating that \$300 would be the minimum for ultra high frequency tele of the type proposed by CBS. Receivers for the present tele channels will cost about half as much, he said. Such sets would include tele, FM and AM dials.

A NEW FM receiving system in which a continuously operating local oscillator is frequency modulated by the received signal was described last month by G. L. Beers of the Radio Corporation of America. Speaking before a meeting of the Institute of Radio Engineers at New York, he described the new circuit, in which an oscillator is locked-in at one-fifth the frequency of the received signal.

With this five-to-one relationship between the intermediate frequency and the oscillator frequency, an equivalent reduction in the frequency variations of the local oscillator is obtained. Received signal frequency variations of ± 75 Kc. are reproduced as ± 15 Kc. variations in the oscillator frequency. The frequency-modulated signal derived from the oscillator is applied to a discriminator which is designed for this reduced range of frequencies.

The oscillator is designed to lock in only with frequency variations which occur within the desired signal channel. The oscillator is therefore prevented from following the frequency variations of a signal on an adjacent channel. A substantial improvement in selectivity is thus obtained.

The voltage required to lock in the oscillator with a weak signal is approximately one-twentieth of the voltage applied to the discriminator. Since this voltage gain is obtained at a different and lower frequency than the I.F., the stability of the receiver from the standpoint of overall feedback is materially improved.

Other performance advantages and the factors affecting the operation of the system were discussed.

EDUCATION in the post-war world will find radio its most effective tool, the School Broadcast Conference was told last month by Clarence Dykstra, president of the University of Wisconsin. "Radio with its ability to bridge instantaneously the gap between classroom and campus and the public," said Dr. Dykstra, "is the best medium we have to build a better citizenry and the kind of world we would like to have."

At the same meeting, Dr. I. Keith Tyler, director of radio at Ohio State University and president of the Association for Education by Radio, envisioned a nation with 3,000 FM stations by 1950. More than 300 of them, he hoped, would be devoted to educational broadcasting. Educators were urged to act boldly before the Federal Communications Commission and Congress to obtain more allocations for education.

LOW-FREQUENCY broadcast stations at the long-wave end of the present broadcast band might interfere with effectiveness of auto-alarms aboard ships, H. V. Looney, FCC engineer, testified last month. The proposal, backed by Panel 4 of the Radio Technical Planning Board, was to establish three new frequencies, 520, 530 and 540 Kc, on which it is believed that accommodation could be found for 150 services.

Auto-alarms are used on ships having only one operator, or two operators, and maintain a watch for SOS signals, ringing a bell which calls the operator to his post when such signals are received.

American auto alarms are tuned to a rather broad band, capable of pickup signals on any frequency between 487.5-512.5 Kc, he said, and while extension of the standard band to 520 Kc. may not ring the bell of the ship alarm systems, it would necessitate using a weaker sensitivity, making it harder for the desired signal to work the alarm.

Ability of different types-of auto alarms to discriminate against unwanted signals varies, said Mr. Looney, and judging by the circuits employed, he expressed the opinion that some of the foreign alarms have poorer selectivity than the American devices.

OUT-OF-THIS-WORLD radio cabinets have made their appearance in wood-starved Britain, a last month's court report from Aberdeen (Scotland) reveals. The manager of a local crematorium was charged with misappropriating 1,044 coffin lids from coffins entrusted to his establishment.

The economical manager freely admitted having taken the lids, which were disposed of to local craftsmen and worked up into radio cabinets and other furniture. He did not appear to consider it an offense to take possession of the material—which was about to be destroyed—and based his defense on that premise. The Aberdonian court disagreed, and convicted him of theft.

NEW CHAIRMAN of the Federal Communications Commission is Paul A. Porter, former publisher and radio lawyer. Ewell K. Jett was named temporary chairman of the Commission at the same time as the announcement of Mr. Porter's appointment.

The new member is well known in the radio field. He served as Washington counsel to Columbia Broadcast System between 1937 and 1942. Leaving CBS, he became an aide to Chester Davis in the National Defense Council. Later he worked as rent administrator in the OPA, and as counsel on the staffs of the War Food Administration and Economic Stabilization Boards, and as publicity director of the Democratic National Committee.

The new appointment was hailed both by representatives of the broadcasting industry and those supposed to speak for the listening public. He is apparently also well looked upon in Congress, whose Interstate Commerce Commission chairman Clarence



Lea described the appointment as "advantageous when new legislation is being considered."

Former chairman James Lawrence Fly, now retired to private life, was warned by the President that he might be called on for advice and counsel, "particularly in the field of international communications." This is believed to be in line with Mr. Fly's own wishes, as his interest in the post-war communications set-up is intense.

THEATRE television wants 75 twenty-megacycle channels for post-war use. A request for that number of channels was placed with the FCC last month by the Society of Motion Picture Engineers.

Through their spokesman, Paul Larsen, the moving-picture men asked that immediate provision be made for 15 channels below 1,000 megacycles. The final program would include 8 channels from 600 megacycles, 7 from 860, 15 from 1,900, 15 from 3,900 and 30 channels from 5,700 megacycles, all bands to be uninterrupted and running up from the reference frequency.

Reason for demanding "immediate" service below 1,000 megacycles, Larsen said, was that present equipment was capable of handling these frequencies, but that apparatus would have to be developed for the higher bands. The film industry will, he believed, contribute substantially to the video art.



A complete medium-power Central Station transmitter for the railroad intercommunication system described below.

Communication by Induction

By R. W. HALE*

INVENTORS have attempted to convey the human voice back and forth between a moving railway vehicle and a fixed way-station as long ago as 1881. There are at least three methods of accomplishing this: (1) direct capacitive or inductive coupling between the vehicle equipment and wires placed alongside the track and as close to the moving vehicle as possible and using voice frequencies, (2) space propagated radio systems using more or less conventional radio techniques, and (3) coupling of the vehicle equipment to the wayside wires using a voice modulated "carrier frequency" which may be as low as 5700 cycles to 300 kilocycles or higher.

The first mentioned technique has not proven very successful. This was partly due to the inadequate equipment available at the time first experimentation was started and partly to the excessive cost of installing and maintaining wayside wires in close proximity to the moving railway vehicle. The

*Halstead Traffic Communications Corporation, New York, N. Y.

second method mentioned has many possibilities and intensive research is under way by several companies. There are several distinct uses for this method and it is probable that considerable information will be available for publication in the future. It is our intention to briefly discuss the third, or induction system.

One of the first induction systems to come into use depended upon the use of a very low carrier frequency (5700 cycles). One of the reasons for the choice of such a low frequency was to avoid the necessity of licensing the transmitting equipment. At that time all frequencies above 10,000 cycles were considered to be in the radio spectrum and required transmitter licensing. It was also believed that attenuation of signals along the track would be less than with higher frequencies. A circuit arrangement was used which suppressed the carrier frequency itself and only the upper side band frequencies were actually transmitted. The advantages claimed were: (1) Increased output of the transmitter at the frequency

being transmitted at any instant, (2) the speech was effectively "scrambled" assuring privacy if it were received by unauthorized persons, and (3) since the emitted frequencies were centered around 5700 cycles, few would be able to intercept the communication. The lower side band was suppressed in a filter arrangement. A simplified diagram is given in Fig. 1.

The operation of the circuit is simple. The 5700 cycle oscillator output is coupled, through T2, to both grids in the same phase relationship resulting in plate currents rising and falling in phase with the grid voltage but with currents through the primary of T3 in opposite directions and resulting in zero voltage being induced in the secondary of T3. This effectively suppresses the carrier.

If modulation is applied, through the microphone and T1, different voltages are applied to the grids of V1 and V2 at any instant, different plate currents flow, the balance in the primary of T3 is upset, and an induced secondary voltage in T3 is applied to the amplifier. If, for example, the modulation frequency at any instant is 300 cycles, the resultant frequencies in the secondary of T3 are: $5700 + 300 = 6000$ and $5700 - 300 = 5400$ cycles. The high-pass filter attenuates the 5400 cycle voltage and passes the 6000 cycle voltage to the amplifier. Thus the 300 cycle modulation shows up as 6000 cycles in the transmitter output. This is applied, through T4, to the front and rear trucks (one of which is insulated from the vehicle) and thence to the rails thus forming a loop output circuit.

By virtue of the "conductive coupling" between the loop and the rails (which form a portion of the loop) currents are caused to flow in the track portion of the loop and for some distance ahead of and behind the loop. This generates a magnetic field around the rails and these lines of force extend out and cut across the adjacent telegraph wires and induce a current flowing in phase with that in the rails. This current can travel a considerable distance along the wires and sets up a magnetic field around the wires which cuts across the adjacent track and causes a current to flow in the rails in phase with that of the vehicle. The wayside wires (or sometimes a buried return cable is used) are a more or less vital part of the scheme in that attenuation is less rapid in

(Continued on page 232)



A Zone transmitter (bottom) and receiver (top). There are only two receiver controls, R.F. and audio gain.

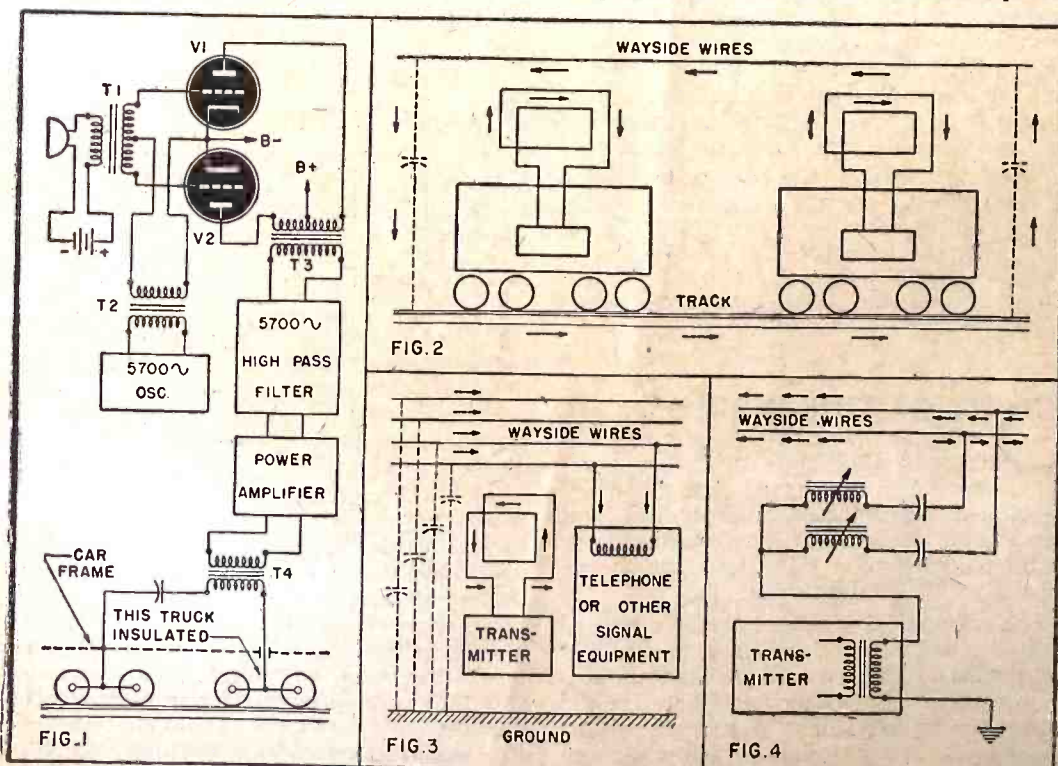
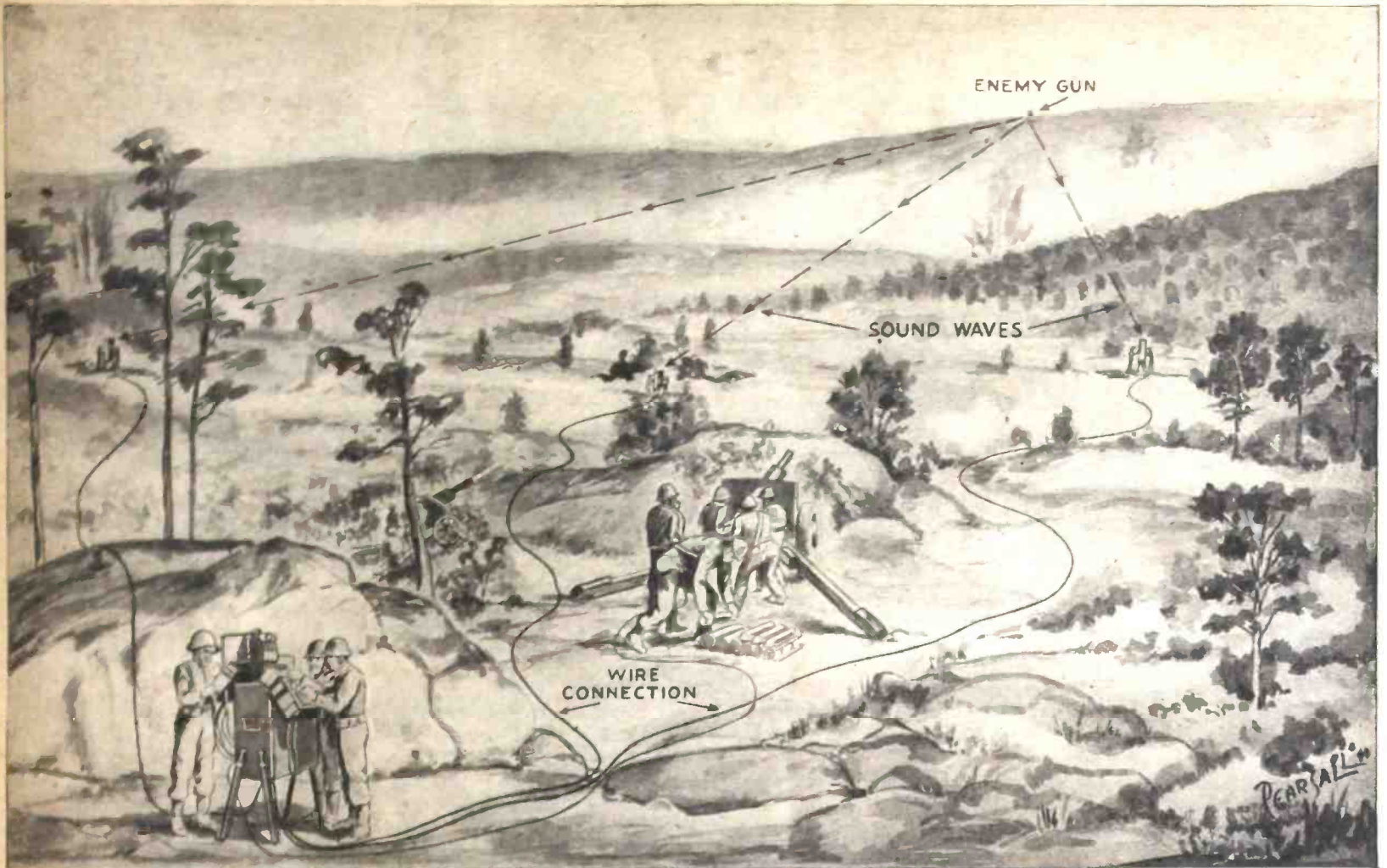

Fig. 1—The "suppressed carrier" scrambled-speech phone transmitter. Fig. 2—A higher-frequency induction system. Fig. 3—The high-frequency signals are balanced out on two-wire systems, thus eliminating interference. Fig. 4—Conductive coupling system.



Principles of the gun locator are illustrated above. Sound is collected by the microphones at three widely separated points and sent back to the central installation. This information is automatically combined and tabulated to show the exact location of hidden artillery.

COVER FEATURE:

ELECTRONIC GUN LOCATOR

By SYDNEY WEINRIB*

ONE of the signs that the war is drawing to a close is the publication of technical matter considered highly secret not many months ago. As the struggle comes nearer to its conclusion the engineer may expect to get details of many items about which we have conjectured since the beginning of the war. One of the more important items now recently removed from the restricted list is the sound ranging apparatus, one of our artillery's most important weapons. In military operations, a large percentage of the enemy artillery pieces must be knocked out by our artillery. To accomplish this, the location of the hostile gun should be accurately determined.

One of the most accurate technical methods of locating enemy guns is known as sound ranging, which involves the determination of the position of an enemy gun by picking up the sound wave produced by that gun. The enemy guns are then neutralized by our counterbattery fire, again supplemented by sound ranging, which locates the explosion of our projectiles and permits adjustment of our guns to coincide subsequent explosions with the position of the enemy gun already located by sound ranging.

The following excerpts are quoted from a Signal Corps military report: "About 60% of our counterbattery firing (resulting from the observation battalion's data) was conducted by sound ranging. Translations of prisoners' statements indicate that they felt it wasn't safe to be near German artillery because we were blowing

hell out of them. They said our fire was inhuman, barbarous, and merciless, and that they never encountered any counterbattery firing like it before. An Arab spy said he had seen a direct hit on a gun and we identified the mission from time and place as a sound ranging mission."

Sound ranging is based on the simple premise that the discharge of a gun or the burst of a shell causes a disturbance or vibration in the air, analogous to the ripple set up on the water when a pebble is thrown into a still pond. The ripple travels outward in all directions from the point of origin at an approximately uniform velocity. The location of the point of origin of the ripple may be determined if the times at which the ripple reaches three or more accurately surveyed points in the pond are known. The sound of the enemy's gun shot is used to locate his position; the sound of our shell bursts is used in counterbattery fire to correct our aim.

At distances of 3000 to 5000 yards behind the front lines, a number, generally six, of special sound ranging microphones are set up in surveyed positions at intervals up to a maximum of 2000 yards. Each microphone is connected to the central station of the sound ranging system by wire lines.

The signal (enemy gunfire, or shell bursts) is picked up by each microphone and transmitted over the wire lines to the central station where it is recorded photographically by an oscillograph. In other

words, the wave shape of the gun discharge is recorded the instant it is picked up by the microphone. Since sound waves travel at a speed of about 1080 feet per second in the air, the time of arrival of the signal at each microphone depends on the distance of the gun from that particular microphone.

From the differences of the times of arrival of the signal at the various microphones, the position of the enemy gun can be determined by means of simple geometric calculations. Further, the record obtained presents characteristics which in many instances identify the calibre of the enemy gun.

The microphone, unlike the human ear, cannot discriminate between the direction of the various sounds and will pick up all sounds of a certain frequency (pitch), thereby recording friendly and hostile guns, presenting hopelessly confused records. To overcome this, one or two observation posts, manned by observers, are placed in front of the microphone positions at such distance that the sound to be located will be heard by the observers a few seconds before the sound reaches the microphones. The observation posts are electrically connected with the recording equipment at the central station, and the observer puts the recording equipment into operation when he hears a hostile gun.

The accuracy of the sound ranging location is therefore dependent upon the measured differences in the time of arrival of a selected sound at several points; the accuracy of these measured differences is in turn dependent upon the sound travel-

(Continued on page 234)

*Engineering and Technical Service, Office of the Chief Signal Officer, U. S. War Department.

FUNGUS ENEMY OF RADIO SETS

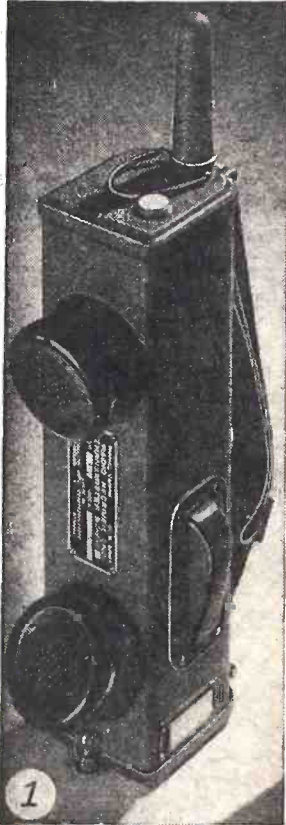

1—Handie-Talkie, most important reason for the elaborate anti-fungus campaign.

FUNGUS, long a problem in tropical radio, assumed vital importance with our occupation of large South Sea Islands and other hot, humid areas. Radios were often out of commission within a week after arriving in tropical regions. Fungi formed conductive paths across supposed insulating surfaces. Other parts were consumed or damaged irreparably by the molds.

Engineers of the Galvin Manufacturing Co., in co-operation with the U. S. Army Signal Corps, studying the question of fungus-proofing radios, resolved the problem into four steps.

- 1—The erection of a tropical setting into which fungi could be introduced and given ideal living conditions.
- 2—The placing of radiotelephone sets, component parts and materials into the setting to observe the progress and effects of the fungus attacks.
- 3—Study and analysis of the effects, and the selection of an efficacious fungicide; also the proposed replacement of attacked materials with substances less subject to attack.
- 4—Testing of the fungicided parts and equipment in the tropical setting to check the results obtained.

RADIOTELEPHONE SETS TESTED

Considered most important of the apparatus tested was the famous Handie-Talkie, shown in Photo 1. The tropical setting, in Photo 2, is simple in construction. It consists fundamentally of a one-piece baked porcelain pan with sides 14 inches high. Storm sash is used for the four walls.

One foot of black loam covers the bottom of the chamber. A black porcelain partition divides it into a lighted and a dark section. A plate glass shelf is placed on top of this partition to protect the articles in the dark chamber from drops of condensed mois-

ture. Apparatus to maintain temperature and humidity at desired levels was provided.

The dark chamber provides ideal breeding conditions for the fungi. Various accessories were used to make conditions as near perfect as possible. The lamp in the foreground (Photo No. 2) provides sufficient yellow and infra-red light for the tropical plants to thrive. A pan inside the chamber is filled with water, and an evaporator maintains humidity between 90 and 95%. Temperature is maintained at 80 degrees during the day and approximately 70 degrees at night. Provision is also made for introducing small amounts of oxygen into the chamber to keep the tropical plants alive and accentuate any oxidation of parts, materials and equipment that would occur under actual tropical conditions.

Four types of typical fungus cultures, *Aspergillus niger*, *Aspergillus ustus*, *Chaetomium globosum* and *Stachybotrys*, were then introduced into the chamber. Three of these molds were of domestic and one of tropical origin.

The dark chamber proved a most fertile breeding ground for the fungi. At the same time, emissions from the tropical plants began to exert their effects on some of the equipment exposed. In a few days, the fungus molds were distinctly discernible. At the end of a week, they were attacking those areas of the equipment and parts which offered good feeding possibilities. Since the fungus is a cryptogamous plant, destitute of chlorophyll, and derives its nourishment wholly or chiefly from organic compounds, its attacks were concentrated on materials of the cellulose type. The fungi would consume the cellulose and leave the lignin untouched so that only a skeletonized frame-work remained. The molds

(Continued on page 247)

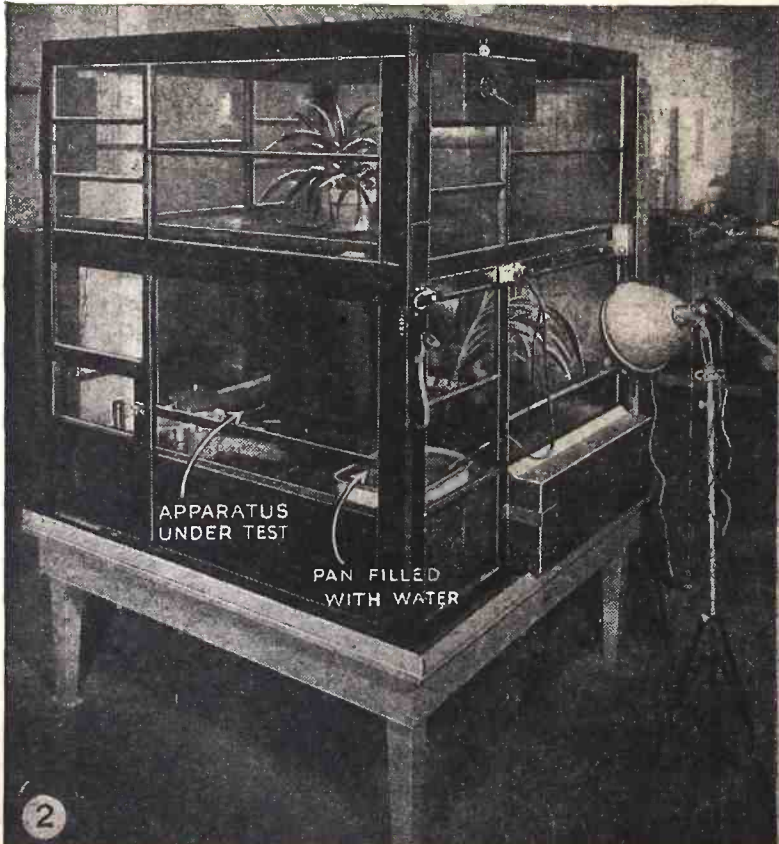

2—The "tropical chamber" in which treated and untreated sets were tested. 3—Close-up of the installation, with apparatus under test.

Photos: Courtesy Galvin Mfg. Co.

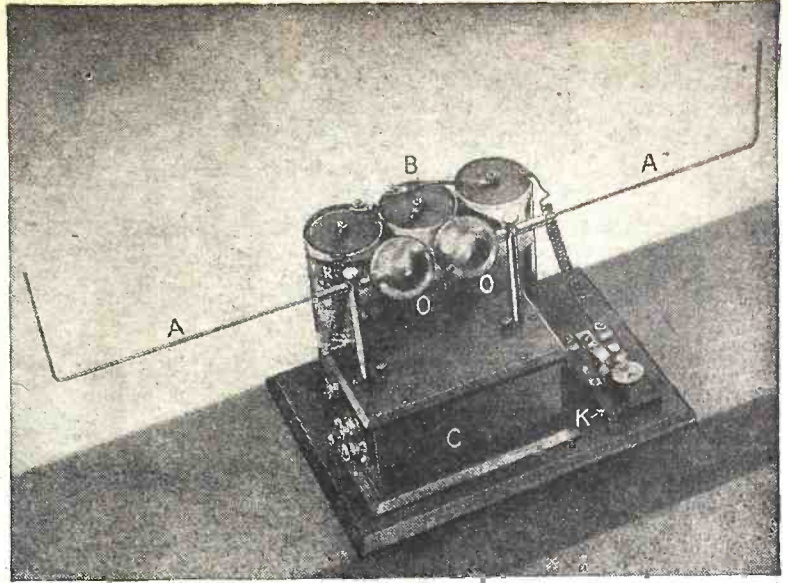
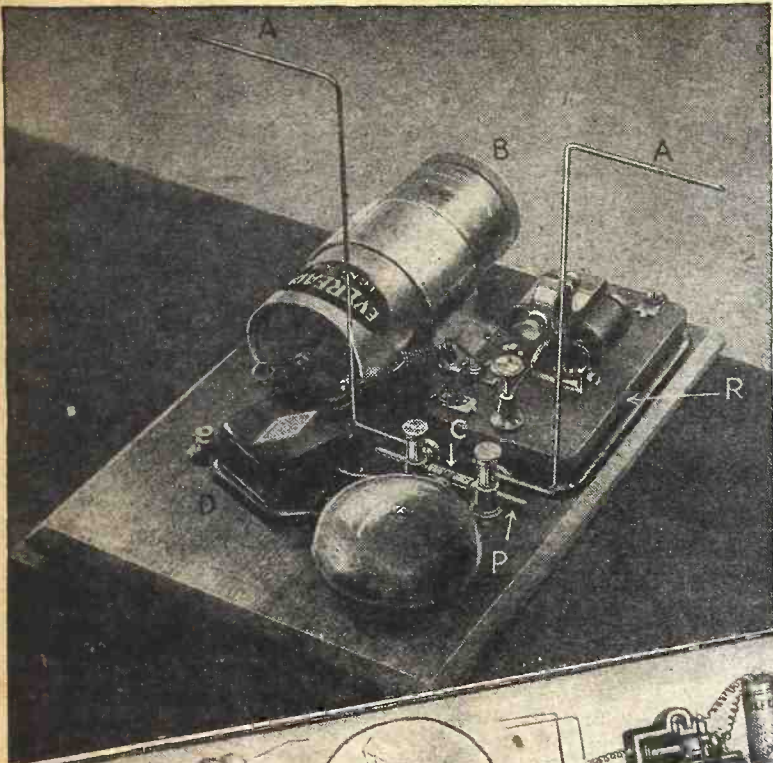

PAT. APPLIED FOR

WIRELESS TELEGRAPH

The "Telimco" Complete Outfit, comprising 1 inch Spark Coil, Balls, Key, Coherer with Auto Decoherer and Sounder, 50 Ohm Relay, 4 Cell Dry Battery, Send and Catch Wires, and Instructions, with Diagrams and Diagrams. Will work up to 1 mile. Unprecedented introduction prices. Agents Wanted. Illustrated Pamphlet.

ELECTRO IMPORTING CO. 32 Park Place, New York

Above—This is a replica of the 40-year-old transmitter. A shows the aerial and counter-poise; B, the three dry cells; C, the one-inch spark coil; O shows the spark-ball oscillators; K, transmitter key.

Upper left—Photograph of the receiver. A shows the receiving aeri-als; B, dry cell; D, the decoherer; C, coherer; P, the adjustable coherer rods; R, 75-ohm sensitive relay.

Lower left—Photograph shows a reproduction of the first home radio set advertisement on record, as it appeared in *Scientific American*, January 13th, 1906.

40 YEARS of HOME RADIO

By HUGO GERNSBACK

THE year 1945 marks the 40th anniversary of the first home radio sold to public anywhere in the world. This may be news to many—even radio men—but it is a fact nevertheless.

To be sure, it was not radio as we know it today, because in 1905 there was no broadcasting. But wireless had been going strong at that time for several years and amateur radio too had just begun. Marconi and other pioneers were transmitting intelligence by the dot and dash method; indeed wireless in those days was rapidly forging ahead.

While all this was going on the public at large knew little or nothing about wireless, except what they read in the papers and in magazines. As for owning a wireless home-set, it had not as yet been born.

Previous to 1905, in 1903-4, the writer had been working on a small portable transmitter and receiving outfit which he felt could be sold to the public. It took over a year to perfect it and make it fool proof so it would work under practically all conditions. Then too, it had to be low in cost so everybody, even those of modest means, could buy the outfit.

This ambition was realized some time early in 1905 and after making a number of models the writer began to market the first home or private radio set ever sold to the public.

Inasmuch as there was not a great profusion of wireless stations throughout the country, it also became necessary to sell a transmitting station at the same time so that people could set up the transmitter and receiver in their own homes. Then while one person was transmitting signals, the other could receive them, or could set up the outfit in one room and ring a bell at

the other end, without any wires whatsoever, intervening.

The outfit that accomplished all this was known as the TELIMCO Wireless Telegraph Outfit. TELIMCO is a contraction of the first letters of the writer's old firm, The Electro Importing Company (E. I. Co.) which became famous between 1904 and 1915 as the first radio mail order house of the world.

Incidentally the outfit was first advertised in the magazine *SCIENTIFIC AMERICAN* in the issue of January 13, 1906. This was the first Home Radio Set Advertisement to appear in print, anywhere.

For a full year before that the outfit was

advertised through the mails by means of circulars, catalogs and pamphlets; several thousand of these sets were thus disposed of. The writer first sold these sets wholesale to a number of electrical supply stores and jobbers throughout the country. He well remembers the incredulous looks of many of the owners of these outlets when they were first approached to buy "wireless sets." It was necessary to make a demonstration in each case before anyone would stock them.

The complete set, both receiver and transmitter, at first were marketed for \$7.50. This was raised later on to \$10.00, at which price most of them were sold. This was a foolishly low figure. But it should be remembered that

(Continued on page 254)

This is the picture diagram of the transmitter-receiver layout. A G is the aerial and ground respectively, for both transmitter and receiver; S is the spark coil; B, batteries; K, transmitting key; R, relay; AS, sensitive spring on relay armature; SD, the decoherer; C, the coherer; 9 and 8 are the relay electro-magnets; 7 and 11, coherer connections; 13 and 16, decoherer binding posts; 14 and 15, the relay contacts.

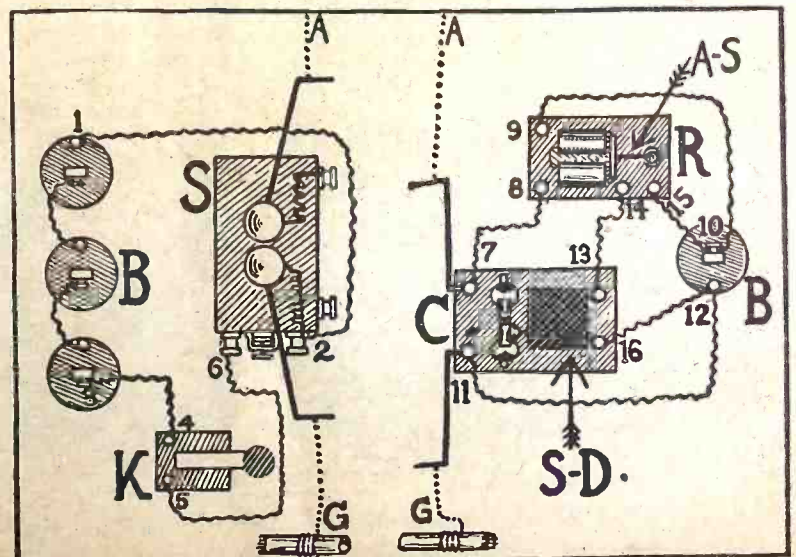

Illustration from 1905 E. I. Co. catalog

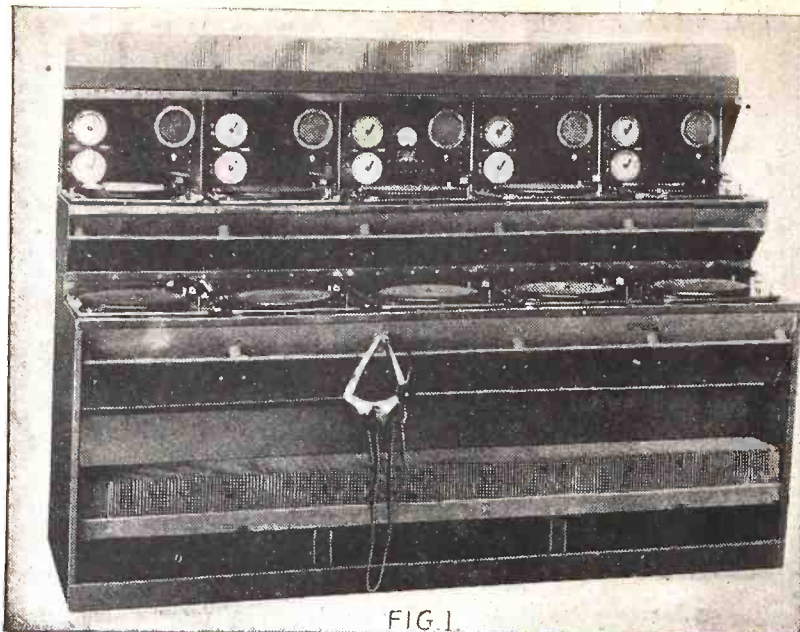

FIG. 1
Front view of typical Central Station panel.

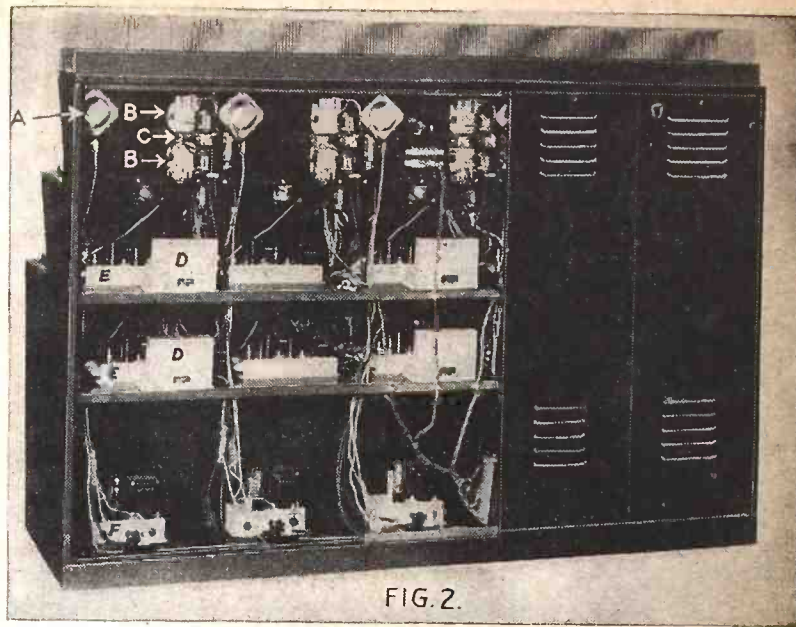

FIG. 2
Rear of panel. Letters are explained in text.

The Remote Juke Box

By KENT B. YOUNG

WHILE the use of telephone lines for distribution of music is not new, the following article is written to clear up some of the mystery of that type of "Juke Box" where you are asked for the name of your selection and do not have to push a button.

In the first place, the building where the main equipment is located, is known as the Central Office. The place where the "Juke Box" is located is called the Remote Station. As the reader proceeds the use of the above two terms will be used to designate the two locations.

The speech equipment at the Central Office consists of: 1. The metal rack about five feet high, divided into two sections.

The entire rack is known as the Board. Each Board consists of ten complete units. Each unit controls a remote station location. Fig. 1 shows a front view of the Board. On top of the Board is a wire rack, into which approximately 1000 phonograph records can be inserted. At the bottom of the Board can be seen another wire rack which holds another 1000 phonograph records. This allows the operator to have any record she may have to use at her finger tips on the instant it is asked for.

Beginning at the left in Fig. 1 are seen two dials set one above the other. Each dial is calibrated left to right from zero

to twenty. These are the dials which light up and show the number of coins inserted at the Remote Station. A stepping relay is used to operate a pointer on this dial. Between the two dials and on either side can be seen the coin counting relays that record the number of coins inserted continuously. To the left of each dial can be seen push-buttons which control a buzzer to notify the operator that a coin has been inserted in case the stepping relay fails to operate. To the right is the permanent magnet monitor loud-speaker which is used to check the quality of the program and also can be used to hear what the person at the Remote Location has to say in case the operator's headset fails. Directly underneath is a toggle switch which turns the power on and off for two complete units. To the right and just below the monitor speaker are two push-buttons. The top push-button connects the monitor speaker to the output of the monitor amplifier for the top turn-table and the bottom push-button connects it to the monitor amplifier for the bottom turn-table. When not in use a dummy five ohm load is cut in across each amplifier output.

There are two phonograph turntables with each section, each one being associated with a Remote Station. These turntables are powered by sturdy, variable speed motors and are equipped with an electric stop. The operator merely puts the record on the turntable platter and moves the pickup arm to the right until a click is heard. By the time she has the pickup on the record the turntable is up to speed. These turntables require very little servicing. They are checked regularly once a week with a neon lamp and a stroboscopic disc for speed. They have no brushes and can be made to operate on 220 volts A.C. by a change in the strapping of the motor windings.

At the right and in the middle of each turntable is a triple-pole, double-throw switch. This switch is used to operate a talk-back system to the Remote Station after it has signalled the operator by means of the stepping relay or buzzer. When pulled forward, it connects a two-stage microphone pre-amplifier into the circuit. The amplifier consists of a 6SJ7 pentode, capacity-coupled to a 6J5 triode, with a volume control be-

(Continued on page 238)

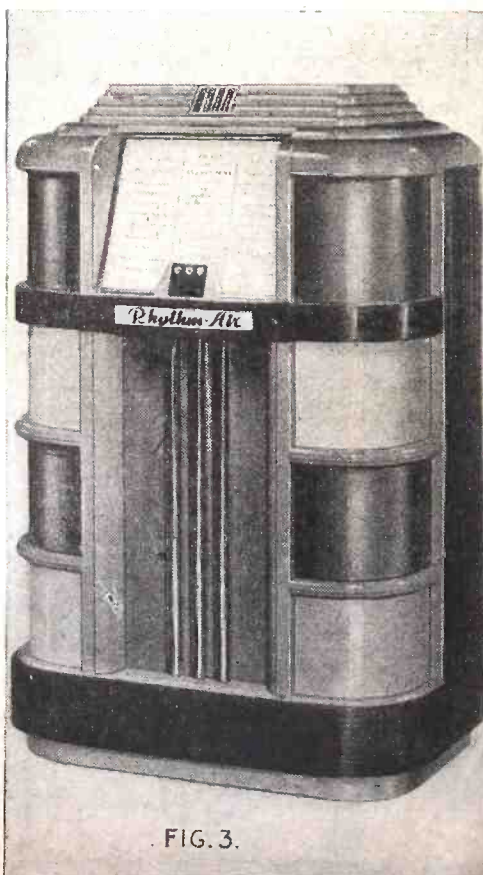

FIG. 3.

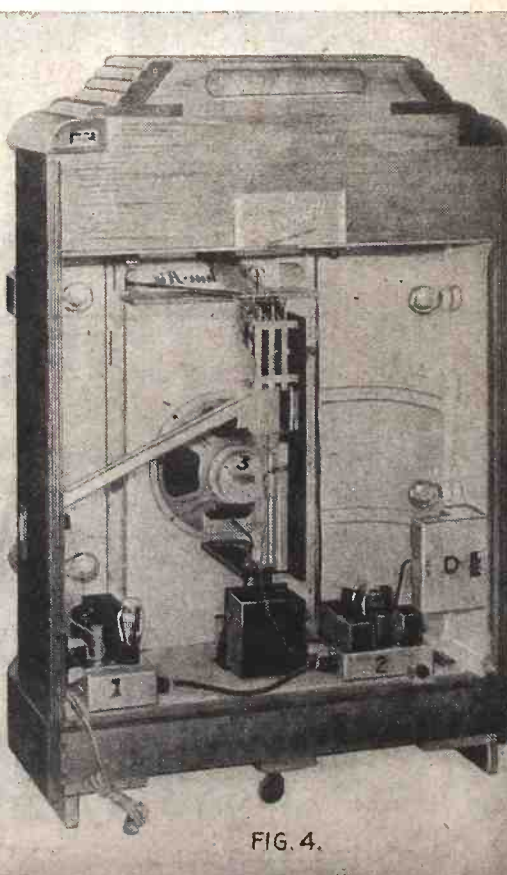

FIG. 4.

Remote Station is like a standard juke box.

Some special parts appear in the rear view.

BROADCAST EQUIPMENT

PART V—AUDIO-FREQUENCY MEASUREMENTS

By DON C. HOEFLER

It has been shown that an attenuation equalizer is "a corrective network which is designed to make the absolute value of the transfer impedance, taken with respect to two chosen pairs of terminals, substantially constant for all frequencies within a desired range." (A.I.E.E. Standards) Our particular interest in this device is as applied to the audio-frequency program lines between the program origination points and the transmitting station. This of course includes all remote lines as well as the regular program wires.

Before using a line for program transmission, the necessary equalizer adjustments are made. An audio-frequency signal voltage of constant value and variable known frequencies is impressed across the line input and the level is measured at the termination with a volume indicator. Preliminary adjustments of the equalizer resistance are made at several of the most important frequencies, such as 1,000, 500, 100, 3,000, 5,000, 1,000 c.p.s., in that order. All these signals must be at very nearly the same predetermined level. Finer adjustments are then made until a flat characteristic is attained, thus insuring equal transmission of all frequencies throughout the required range.

For high-fidelity transmission and to satisfy good engineering practice, the entire broadcasting system must be substantially flat (i.e., within ± 1 db) from 30 to 10,000 c.p.s. Although the program line is now assumed to be properly equalized, the over-all characteristic must take into consideration the remainder of the system as well, including the microphones, speech equipment, and transmitter. However, when frequency-run measurements are made, the microphone is excluded from the apparatus and the characteristic curves provided by the microphone manufacturer are employed.

The arrangement for a frequency run is illustrated in the block diagram of Fig. 1. The source of steady tone is an audio-frequency oscillator. For greatest accuracy, it is important that the harmonic content of the oscillator be of a very low order. The oscillator output is fed into the preliminary amplifier through a resistance network, for purposes of isolation and impedance-matching.

Before commencing the frequency run, it is necessary to ascertain that there is present neither regeneration caused by an unbalanced circuit nor R.F. feedback induced in the supplementary equipment assembled for this test. To verify the absence of regeneration due to an unbalanced circuit, after all equipment has been turned on and allowed to warm up, the transmitter is adjusted to its authorized carrier power and the gain controls and speech amplifiers are set at normal operating levels. The A.F. oscillator is set at about 10,000 c.p.s. at any convenient level. After a few moments, the oscillator and resistance network are removed from the circuit by opening switch S. If the line-amplifier volume indicator and the modulation-monitor meter indications do not fall to zero immediately, there is some regeneration present.

When testing for the presence of R.F. feedback, the audio oscillator remains in the circuit but its power is removed. The modulation-monitor and volume-indicator meters are again observed. Any erratic

fluctuations or failure of these instruments in indicate zero is evidence of R.F. feedback. Furthermore, if the modulation system is a class-B amplifier, and its static plate current increases when the speech amplifiers are turned on and connected into the circuit, this is further proof of R.F. feedback. In this case, R.F. energy is be-

sirable values, as the sensitivity of the human ear is maximum around 1,000 cycles, and a low percentage of modulation prevents any possible overloading, with its resultant harmonic distortion and increased meter readings. The transmitter should previously be carefully adjusted for symmetrical modulation. Nevertheless, as a further precaution, all calculations and plotting should be made with reference

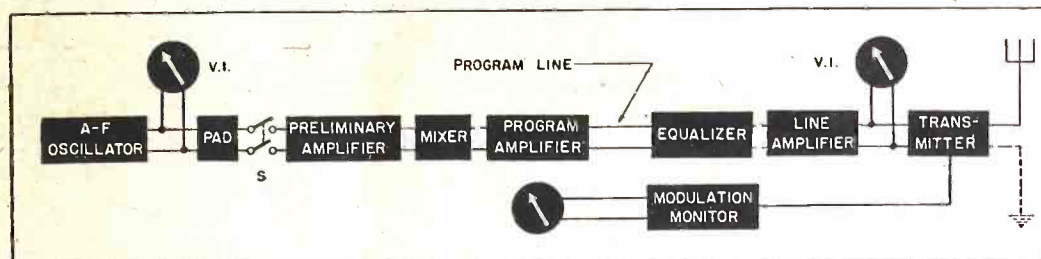

Fig. 1—Oscillator, pad, output and modulation meters as laid out to make a frequency run.

ing induced and rectified in one of the amplifiers, which in turn modulates the transmitter with the undesirable signal, at a frequency which is often beyond the upper limits of audibility.

The following procedure should always be used after completing a new installation or when the over-all frequency characteristic is known to be non-linear and a precise determination of the deficiency is desired.

A reference frequency and percentage of modulation must first be established, such as 1,000 c.p.s. and 50% peak. These are de-

to the same modulation peak, whichever is chosen for the test.

The transmitter has now been adjusted to its regular operating power, and the audio oscillator is set at the 1,000-c.p.s. reference frequency at a convenient output level. The volume controls are then adjusted until the modulation-monitor meter reads 50% modulation. Thereafter, no further adjustments are to be made on any of the equipment, except that the audio-oscillator output is kept exactly the same for all frequencies. After adjustments at the ref-

(Continued on page 235)

FREQUENCY RUN

DATE () REGULAR () A.M.
 () EMERGENCY TIME () P.M.
 () INTERCOMM

FREQUENCY, CYCLES PER SECOND	LINE AMP. V.I. WHEN AUDIO OSC. V.I. READS	MODULATION MONITOR D.B. SCALE	
		POS. PEAK	NEG. PEAK
(reference) 1,000			
500			
100			
60			
30			
2,000			
3,000			
4,000			
5,000			
6,000			
8,000			
10,000			
(reference) 1,000			

REMARKS:

SIGNED:

Fig. 2—Frequency checks are taken in the order shown above, and data is carefully tabulated.

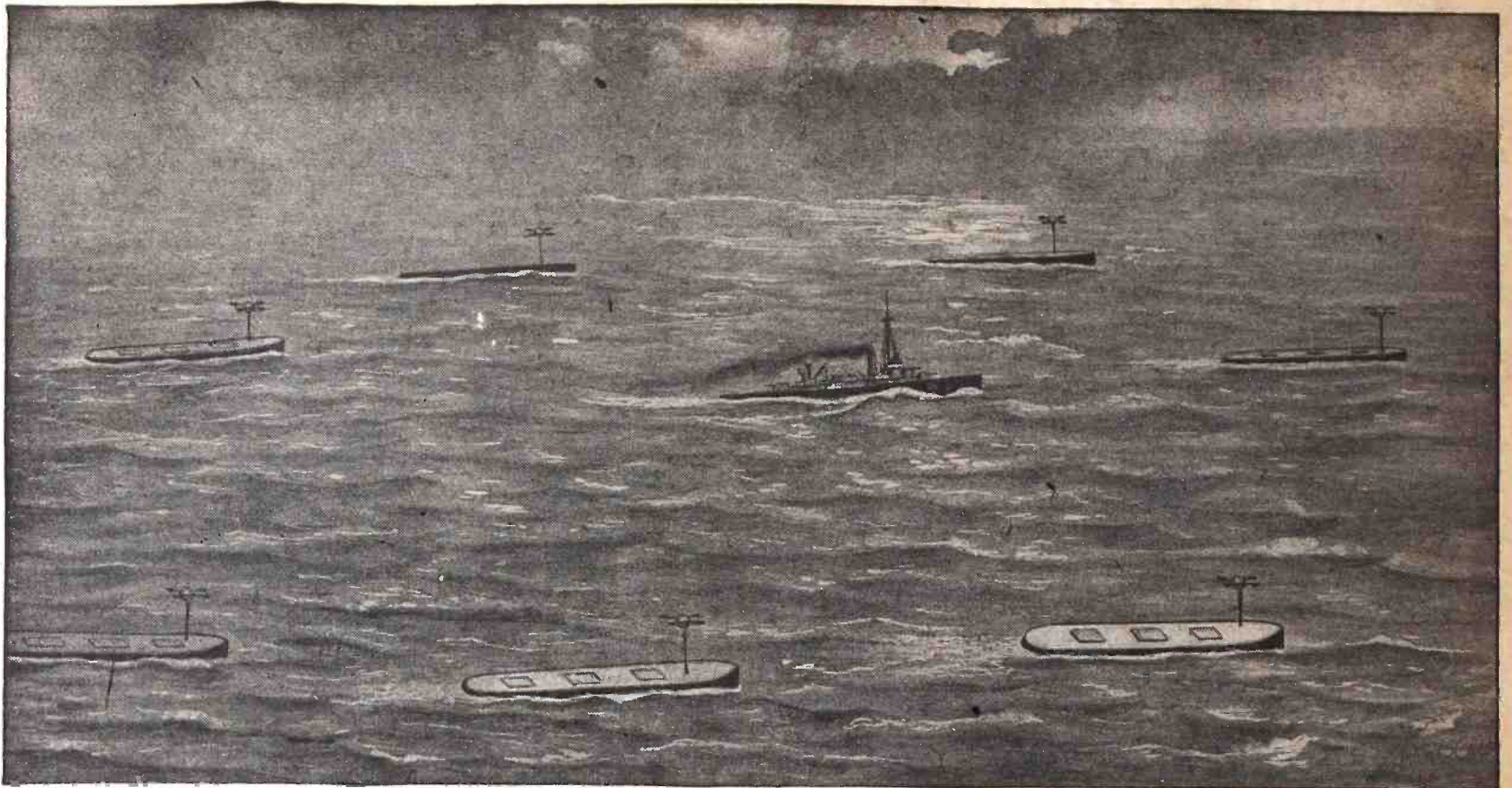

Fig. 1—How the crewless ships of the convoy would look "grouped around their "brain" which steers them and guards against enemy attackers.

A RADIO ROBOT CONVOY

By I. QUEEN

NEW and ingenious electronic war weapons are being disclosed from time to time. We already have guns directed and fired; tanks, torpedoes and planes controlled; mines located and planes exactly located; all by electronic methods. Another recently disclosed development provides for further minimizing submarine dangers. By this means a convoy may be remotely and automatically controlled by radio. It is the subject of U. S. patent 2,339,257.

The plan involves the use of but a single ship as guard, controlling and guiding eight or more freight-laden vessels (Fig. 1). The guide-ship is of the destroyer or corvette class and is surrounded by the freighters which are 2000 tons dead weight, 250 ft. long, 36 ft. beam and 37 ft. deep, each

Diesel powered. Each is built of concrete and contains a series of water-tight compartments to make it comparatively invulnerable to torpedo attack.

The convoyed vessels contain no provision for a crew! There is therefore the great advantage that every bit of space may be utilized for cargo.

Each convoyed ship is normally under the guidance of an "automatic pilot" which includes the use of a radio loop arranged to constantly seek a position at right angles to the direction of received radio signals and in this way to control the course. This may be accomplished by operating the rudder from a motor which in turn is controlled by the incoming radio signals. Since the null point of the loop corresponds to a direction at right angles to received radiation, the motor comes to rest only when the loop reaches the above position, and previous adjustments give the ship the desired course.

If for any reason a change of course is desired or if the ship wanders, the destroyer may then switch over to remote control. As shown in Fig. 2, a telephone dial is used to transmit a sequence of impulses of alternate frequencies, 600 and 1500 cycles. For example, if "4" is dialled, four such alternate impulses are transmitted to modulate the R.F. carrier, which is in the UHF band, to limit its range of reception. Each number dialled corresponds to some desired control such as speed, course, automatic alarm, etc. After the proper motor is thus selected, a steady note of either 600 or 1500 cycles may be transmitted by pressing a button. The latter operation selects direction of rotation of the proper motor, so that there is available a slower or faster speed, a change of course, etc.

The set-up at the receiver is shown in Fig. 3. The output is filtered and the tone frequencies separated and passed through

rectifiers. One tone causes attraction of relay armature (R), while the other causes repulsion. The biasing winding (BW) serves to hold the armature in whichever position it last attains (since the direction of current through it depends upon the armature position). Alternate pulses therefore cause armature vibration which in turn charges and discharges condenser C, and therefore "pulses" the relay (S) in such a way that the selector code wheel rotates. The latter may be a Western Electric type 60 BR. Depending upon number dialled the code wheel will close the desired active contact. Five of these are shown. Each contact is wired to close a relay to operate the desired motor.

The rectifier output also operates another relay (T). This does not respond to pulses, but its armature is attracted or repelled, depending upon which steady tone is transmitted. The armature position selects direction of rotation of the motor which has been dialled.

To correct for any sudden disturbance to the course as by high seas, etc., another automatic device is used. A compass card has its periphery cut out so as to provide radial edges 90° apart, two opposite quadrants being opaque, the other two being transparent. A photocell and light source are so arranged that the compass card between them controls the amount of light passed. Normally half of the available light falls on the cell. The compass card moves with the ship so that a change of course results in more or less light falling on the cell. The cell voltage output is used to control the rudder and the compass card is thus automatically brought back to its normal position.

The patent has been issued to Andre Maris Embiricos and Frederick B. Woodworth of New York State, for this plan. Besides its war use, it has definite peacetime advantages since there are no crew requirements and the ship construction can be such that it is practically unsinkable.

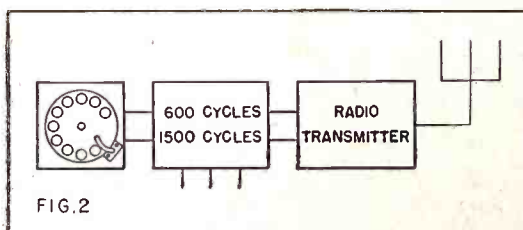

FIG. 2

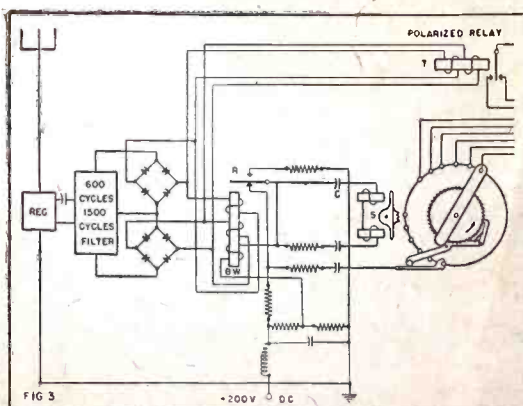
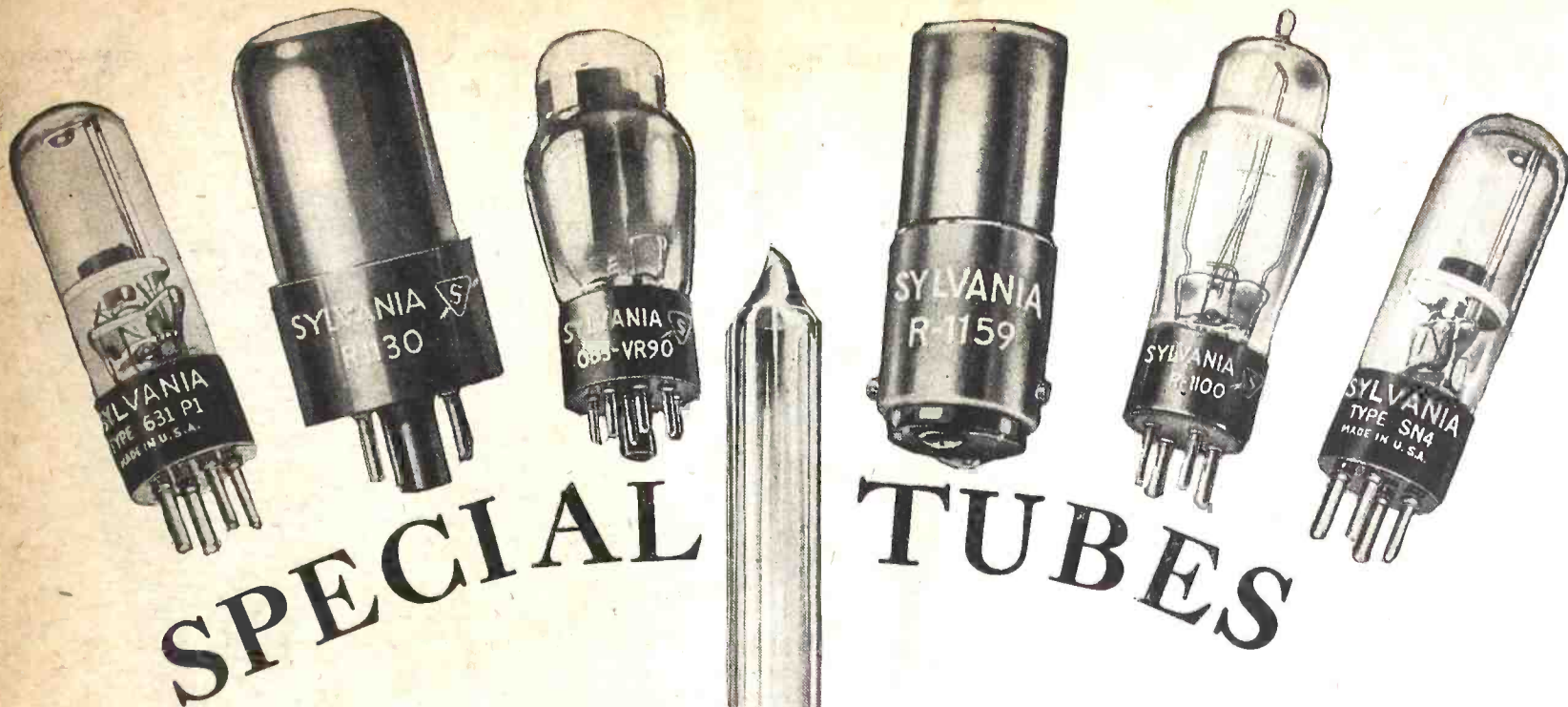

FIG. 3

Fig. 2—Telephone-dial operating mechanism.
Fig. 3—The robot ships' receiving apparatus.



SPECIAL TUBES

THE ROLE of the electronic tube in industry is ever more and more varied. To meet special needs, many types of tubes have been and are being devised. Some are not widely known—others are at present restricted to war uses only. These and others will play an increasing part in the development of modern electronics when civilian needs again assume priority. A brief description of a number of interesting specialized Sylvania tubes is given below:

STROBOTRON

Type 631-P1 and SN-4. These two tubes are similar except that the former is designed for viewing moving objects, the latter for electronic relay work. They are cold cathode tubes. The 631-P1 emits sharp, brilliant flashes of red light at low frequency. By viewing rotating objects under its light, an illusion of "stopped" or "slow" motion is created, thus allowing study, adjustment and alignment of rapidly moving machinery. This tube, for instance, is used in the General Radio 631-B Strobotac, a device directly calibrated to produce from 600-14,400 flashes per minute, (of 5-10 microseconds in length). The SN-4 is an electronic relay with no moving parts operating at a maximum of 60 pulses per second.

A basic circuit for either tube is given in Fig. 1. Switch closure places the voltage on C_2 between cathode and grid #1 to initiate discharge. The condenser assumes the full DC voltage while the switch is open. Other tube elements may be utilized as shown in the chart.

PIRANI TUBE

R-1110. This tube may be used to measure a vacuum between the limits of 10^{-1} to 10^{-5} millimeters pressure. The Pirani principle is that of measuring the resistance of a wire placed in an atmosphere of low gas pressure. Since heat conduction changes with the pressure, a current meter determines the degree of vacuum. The tube tip (which is open) is sealed into a vacuum chamber which it is to measure. The filament resistance is about 6.6 ohms when cold and rises to about 16 ohms with 100 M.A. flowing (in a vacuum).

THERMOCOUPLE TUBE

R-1100. This tube may be used for similar applications to the above and has the same range of pressure measurement. It also works on the principle of varying thermal conductivity with gas pressure. In this tube,

however, the center point of the filament is the hot junction of a thermocouple, the output of which is measured to indicate degree of vacuum. Its filament resistance is 1.5 ohms, thermocouple resistance 3.5 ohms. Like the previous tube, its open tip is sealed to form part of the vacuum chamber under measurement.

REGULATOR TUBES

R-1159. This tube finds application in low current drain circuits for voltage regulation. The voltage across it varies with the current flowing through it, thus maintaining the voltage across the load.

OB3/VR90 OC3/VR105 OD3/VR150. These three tubes may be used in circuits requiring higher operating currents. The load in this case is placed in parallel with the tube, which maintains a constant voltage with widely varying current flow. The first code letters in the tube names determine operating current range, the last number being the operating voltage.

FACSIMILE TUBE

R-1130. This is a cold cathode tube designed to emit a pin-point of photographic light in the range of 3500-6500 Angstrom units. It may be used in facsimile receivers where a modulated EMF is applied to the tube. The emitted light is focussed onto a sensitized photographic paper attached to a revolving cylinder.

NEAR ULTRA-VIOLET LAMPS

Blacklight Lamp. Sources of near-ultra violet light, these lamps resemble ordinary fluorescent tubes, with a red-purple glass envelope, which acts as a filter to absorb visible light. They can be operated with regular fluorescent lamp equipment and fixtures, though the smaller sizes have a special base. As they cause many naturally fluorescent materials to glow, they are useful for many inspection purposes, as well as their ordinary uses in lighting fluorescent dials, etc. As an example, the lamp is used in sorting acetate and cellulose yarns, which glow differently under the light though they may resemble each other very closely under ordinary light.

RP-12. This fluorescent lamp represents a compact source of visible and near ultra-violet emission in the range of about 3600 Angstrom Units. Operating from a 24-volt D.C. source it may be used to illuminate fluorescent painted dials such as an airplane instrument panels, for inspection lights, etc.

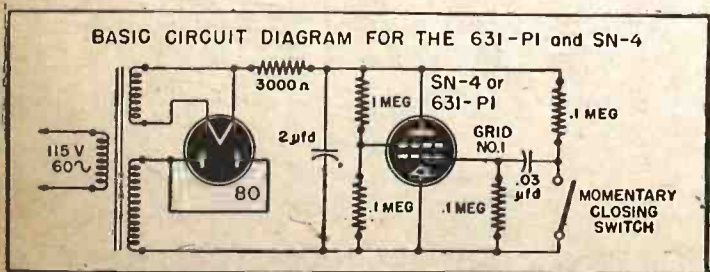
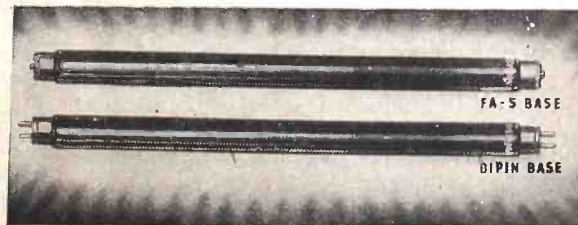
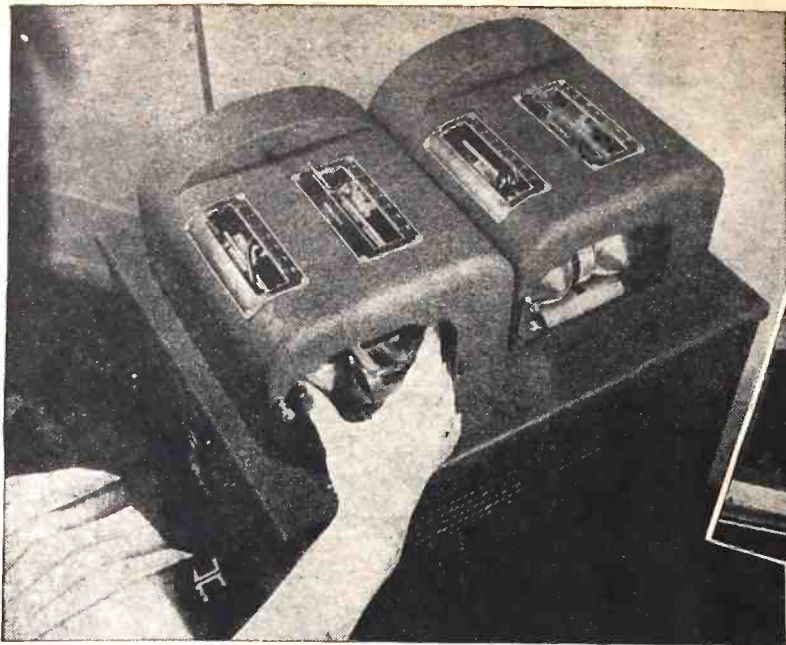

Fig. 1—Strobotron. Light is emitted directly from the tube.



Blacklight lamps resemble ordinary fluorescents.



A conversation recorded by the new electronic machine.
Courtesy
Dictaphone Corp.

How cylinders are changed on the electronic recorder.

ELECTRONIC DICTATION

By PHIL GLANZER

THE application of electricity to business machines has grown apace and is still being studied. One of its chief virtues is that it lessens operator fatigue appreciably, but is admittedly noisy. The electric typewriter is now becoming common, and electricity has been applied to adding machines and other computing devices which formerly depended on hand labor. The electron tube has been slow to come into office use, though there is little doubt that many computing machines of the future will be electronic.

One of the newest developments is voice recorder electronic dictation. This combination of ordinary sound amplification and recording has so many advantages over older dictation recorders as to constitute an entirely new instrument, with a surprising new range of applications. The latest model which has been used by the Government since start of the war and by some high-priority business offices, is contained in a neat steel stand, fitted with a smart desk or hand microphone, instead of the old mouthpiece and speaking tube. The microphone will pick up messages from almost any point in the room, thus is useful for recording conferences as well as for taking down letters, memoranda, instructions and reports. A larger model will record speeches delivered in an auditorium.

SOME NEW FEATURES

This device may be equipped with two cylinders, instead of one. These operate automatically, the one taking over just a few seconds before the first is completed, thus ensuring uninterrupted recording, and frees the person dictating from necessity to interrupt his train of thought to put on a fresh cylinder.

Still more recent models use a plastic flexible material, instead of the wax cylinder, as the recording medium. Chief advantage of the plastic material over the wax cylinder is in saving of space and the fact that the plastic is practically indestructible. The plastic loops are used but once whereas the wax cylinders are re-surfaced by a shaving machine, and used over and over again.

One of the fantastic applications—to the layman at least—is its ability to pick up

two-way telephone messages. Merely by placing the telephone on a slim, plastic stand which resembles a small black ledger, but which contains an induction coil, most models of electronic voice recording machines will take down conversations from both ends of the telephone.

Before the war a large concern marketing perishable products used one for taking down salesmen's orders, transmitted from various points in the country to head office. It was found to be a time-saver, as well as a valuable supplement to telephone service. Orders could be placed faster and customers serviced quicker.

Here's how it worked: a salesman was given a number and at a certain hour each evening he was allotted a special line linking him with head office where a boy on duty operated the receiving end of the machine. When the switch was thrown, the salesman simply read his orders over the phone as fast as he could go, the orders being recorded on a cylinder. One transcription of the information on the cylinder provided the order, the invoice, necessary labels for shipment, etc. This was much faster than the old system and the salesman was saved time-consuming and tedious order-writing.

Possible postwar uses are visualized by legal firms. By installing an electronic voice recorder, the firm will save time when a junior, for instance, has to search a title at the Lands and Deeds Registry Office. Instead of laborious notation of the facts in the case, he will report them over the phone onto a voice recorder.

Already these electronic recording machines are used in the X-ray and pathology departments of some American and Canadian hospitals. The doctor records his findings by means of a microphone pick-up, operated for start and stop by a foot-pedal, thus freeing both hands for the handling of specimens or X-ray plates.

AIR-TRAFFIC CONTROL

The newer electronic recording machines, those using the plastic material as a recording medium, have found their most im-

portant war use up to the present in control of airway traffic.

A staff of men and women, stationed at various points throughout the country, send out continuous instructions regarding speed of flight, altitude, weather and traffic information to the pilots of planes. Transmitted by direct wire to the airfield, these messages are relayed by radiophone direct to the planes, which in turn notify the ground they have received the information.

A complete record of all these ground-air conversations is carefully kept by means of batteries of voice recording machines.

They have not yet been released to the public, although they are reported in use by the American and Canadian governments.

The electronic recorder has also been used extensively since the war by Government listening posts where monitors retain a permanent record of propaganda broadcasts from enemy stations.

BATHING-SUIT CONTROL

RADIO-CONTROLLED "explosion boats" are the latest Nazi attempt at electronic control of weapons from a remote point. According to reports published last month, these last-gasp resistance weapons were light speed-boats the size of a pleasure-type motorboat.

The speedboat goes out under escort of a "command boat" until it is in range of its target. It is then released under the control of a pilot, who—clad in rubber suit and lifebelt—operates it till within a few hundred yards of the target. He then presses a button turning it over to radio control and goes over the side. The command boat immediately takes over and guides the explosive unit toward the target.

The floating pilot is later fished out of the water by the command boat "if circumstances are favorable," according to a German broadcast describing the new weapon.

(See also article, "Radio Motor-Torpedoes, April, 1944, *Radio-Craft* on the same subject.)

Electronic Symbols Now Co-ordinated

By FRED SHUNAMAN

A MINOR and undesirable effect of the rapid advance of electronics in the industrial field is the confusion which has resulted in graphic symbols and schematics. What to a communications man is the symbol for a resistor is a coil to the power engineer. Conversely, the radioman unquestioningly accepts as a fixed condenser the power symbol for a contactor!

These differences were of little importance as long as the two types of drawing seldom entered overlapping fields. Today the industrial trend of electronics is further accelerated by special conditions surrounding war production. The most striking instance of conflict is in the wiring diagrams of military airplanes, where both power and communications are involved. Under such circumstances, valuable time may be lost installing apparatus in such planes. The maintenance problem is even worse. In many cases one man may be compelled to work with both types of diagrams at the same time. Confusion is bound to result, and confusion may well spell loss of life in a critical situation.

Two conferences—held under the auspices of the Armed Services and the American Standards Association—recently met with the idea of coordinating the two systems of symbols. A large number of industrial organizations and some individual industries, as well as publications dealing with electronics, were represented.

NEW SET OF GRAPHIC SYMBOLS

The conference established the group of symbols shown in Fig. 1. These coordinated electrical and electronic graphical symbols are intended for use both in communications and power work, and—it is hoped—will put an end to the costly and dangerous confusion resulting when both power and communications diagrams have to be used concurrently by persons whose electronic training may have been short and intense.

Due probably to the speed at which decisions had to be made, and possibly in part to mixed motives of the participants, a real opportunity to straighten out the symbol situation was missed. Much confusion still exists, and some changes were made which seem to create difficulties instead of resolve them, by making schematics unfamiliar to some who were trained to recognize the older ones and who lack the background which makes the transition to new diagrams easy to the experienced radioman or engineer. A temporary result is the existence of three types of schematics instead of two—the new coordinated kind and the two old forms.



The symbol for condenser-contactor still exists (as a contactor) to confuse the communications man, in spite of the fact that a common symbol for contactor exists and is readily understood by both radio and power engineer. This symbol is still retained for sequence contacts (Fig. 1) and the coordinating authority went so far as to provide that "the symbol for sequence contacts may also be used for a simple contact in order to maintain uniformity and

avoid confusion on drawings." (See Note C on Fig. 1.)

The standard power symbol for a fixed condenser,  was passed over in favor of an entirely new one, in spite of the fact that it conflicts with nothing in radio diagrams and is recognized by communications men. (Not so many years ago QST attempted to popularize the symbol as a designation for all condensers of more than 1 mfd. capacity.) It is an old communications symbol, and radiomen still understand the sign, though they seldom use it.

Another peculiarity was the abandonment of the symbol  for variable or adjustable condenser. Since this was common to both systems (ASA Z32.5—Standards for Telephone, Telegraph and Radio—page 9, symbol 2.142; and ASA Z32.3—Standard Symbols for Power, Control and Measurement—page 6, symbol 3.5) this action could hardly have been in the interests of unity.

CONFUSION WORSE CONFOUNDED

Indeed, more than coordination must be in view when a symbol common to both systems is abandoned in favor of one never before seen. One of the answers given is that many of the draftsmen present did not want to exchange simple symbols for ones more difficult to draw—that the conference heard a strong voice for the simplification of symbols as well as their unification. If this were the case, it was a praiseworthy aim. In the present situation it can only serve as a horrible example of the results of mixed motives. The cause of simplification was worse served than any of the others which may have been represented. For example, the symbol for a variable condenser,  is more complicated than any of those in use hitherto. The trimmer  includes all the complications found in the worst designs formerly used and adds a letter T to them.

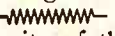
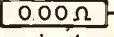
The present contactor symbol is ascribed to a sentimental unwillingness among power men to part with a sign that had served them long and faithfully. A similar feeling must have prevailed among communications men, for the symbol  for the resistor is retained, in spite of the fact that a non-confusing alternative  is provided. A further disadvantage is that the communications resistor may readily be confused with a coil by power men. The rectangle with the ohmage of the resistor printed inside is a perfect symbol, combining clarity and completeness of information with economy of space.

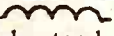
The coil symbol is now similar to that used in communications, with the exception that an open-work version,  may also be used. This will be understood without hesitation by all concerned and can cause no trouble.

A study of schematics reveals that in the communications field, at least, there is room for vast improvement in symbols which were not in need of coordination and were therefore not considered by the coordination conference. The American Graphical Standards provide no symbol for a powdered-iron











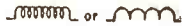

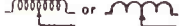

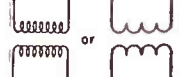

CAPACITOR FIXED		INDUCTOR FIXED	
VARIABLE or ADJUSTABLE		VARIABLE or ADJUSTABLE	
NOTE A			
* CONTACT SIMPLE OPEN		WITH IRON CORE*	
			
NOTE B		TRANSFORMER	
SIMPLE or SEQUENCE			
NOTE C			
RESISTOR		WITH IRON CORE	
FIXED SIMPLE			
DETAILED			
VARIABLE or ADJUSTABLE			
SIMPLE		OPERATING COIL	
DETAILED		SIMPLE	
SIMPLE		DETAILED	
DETAILED			

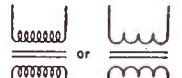
Fig. 1. NOTE A: Where it is necessary to identify the capacitor electrodes, the curved element shall represent the outside electrode in fixed paper-dielectric and ceramic-dielectric capacitors, the negative electrode in electrolytic capacitors, and the movable element in variable and adjustable capacitors. When it is desired especially to distinguish trimmer capacitors, the letter T should appear adjacent to the symbol.

NOTE B: The line representing contacts shall be approximately equal to 1/4 times the width of the gap between the lines.

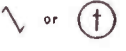
NOTE C: The symbol for sequence contact may also be used for a simple contact in order to maintain uniformity and avoid confusion on drawings.

* This symbol must always be used with an identifying legend within or adjacent to the rectangle.

† This symbol must always be used with an identifying legend within or adjacent to the circle.

core, as used in R.F. and I.F. transformers. One of the largest receiver manufacturers denotes such a core with a series of large dots or bullets down the middle of the space between the two coils. Most others use a sign resembling that for iron cores in audio transformers, but with dashed instead of solid lines. There are a few variations, some of which indicate a withdrawable core (permeability-tuning). One looks in vain among the radio symbols for a rectifier, though happily the standard symbol can be found in the Power, Control and Measurement list. It is understood that the new Communications Standards—which will be published before this is printed—will carry a number of these symbols.

Another group of symbols which radio diagrams treat in several ways are those for different types of microphones. The Graphical Symbols do provide signs for these, but they are aesthetically such horrors that no radio magazine has ever adopted them. The same reasons may have prevented adoption of the Standard Symbols for phonograph reproducers (pickups) though here the radio industry is practically in agreement on its own symbols.

THE ROAD TO IMPROVEMENT

It will be evident from the foregoing that there is much room for improvement in radio symbols, both those recently "co-ordinated" and others not so dealt with. Radio-Craft believes the best method to bring about such improvement is to adopt the latest system—with all its faults. This will be a step toward one uniform system

(Continued on page 242)

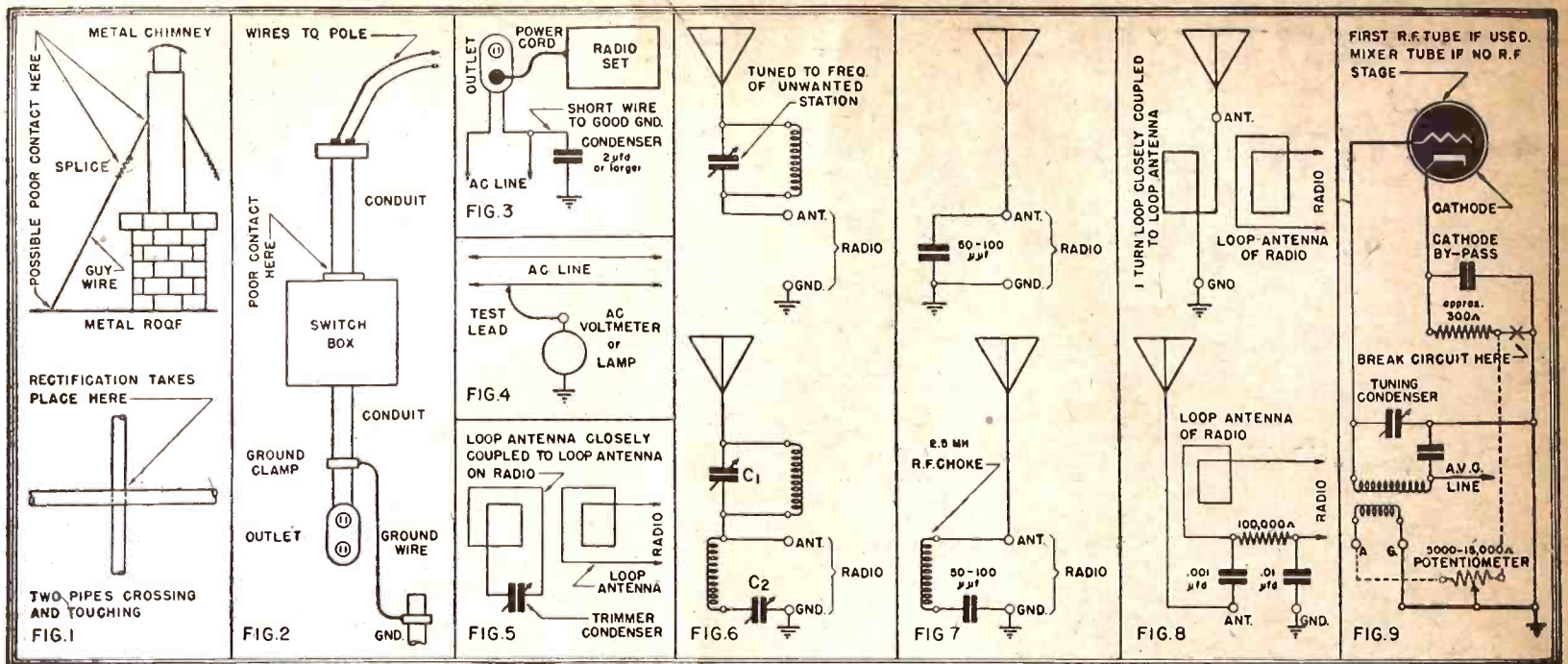

"STATION RIDING"

Cross-Modulation Presents Serious Problems to the Serviceman

THE term "Station riding" was first heard by the writer in San Francisco in 1930. It was used by radio technicians of the Bay City to describe a type of radio interference very prevalent in that area. Station riding is the type of interference that allows an unwanted signal to "ride" the carrier of a wanted signal. When a signal is tuned in on a radio receiver and station riding is present, two or more signals are heard at the same time. When the receiver is detuned, neither the desired nor the undesired signals are heard. In the case of a broad tuning or non-selective receiver, interfering signals are usually heard between stations. Station riding affects highly selective radio receivers as well as receivers with poor selectivity.

To rid the receiver of this annoying interference, many schemes were tested. Changing the antenna, a better ground connection, wave traps, etc., were tried. These methods often reduced or eliminated the interference. In other cases, the source of interference had to be located and the remedy applied at the source.

The source of station riding is usually hard to locate unless a radio interference locating device or a sensitive portable radio receiver is used. Typical causes of station riding are poor electrical contact between sheets of metal on a metal roof, two pipes touching but not making good electrical contact, antenna touching metal drain pipe, poor electrical contact at splices on guy wires attached to antenna mast or metal chimney, or almost any mass of metal making poor electrical contact to another mass of metal. (Fig. 1). The theory that has been advanced on the cause of this station riding claims that rectification of strong radio signals takes place at the point of poor electrical contact. (See "Foxhole Emergency Radios" in September *Radio-Craft*.) When two or more radio signals are rectified at these points, their sum and difference frequencies are radiated by the metal objects. The more signals that are picked up and rectified, the larger is the number of radiated beats. When several

By LEO G. SANDS*

signals are rectified in this fashion, nearby receivers may pick up jumbled signals every few kilocycles on the receiver tuning range.

In one instance, the writer was called to diagnose a case where the listener complained that the radio was unusable. It was found that half a dozen mixed signals were being received every ten kilocycles throughout the broadcast band. Every carrier, including the high power local stations, was accompanied by half a dozen interfering signals. Line filters and wave traps were tried to no avail. Being a loop antenna type receiver, an outdoor antenna and ground were tried. The owner felt that it must be the fault of the radio receiver. One of another make was tried and the results were found to be just as bad.

TRACKING DOWN THE TROUBLE

Armed with a portable receiver (which also suffered from the same interference), the writer followed the power lines in front of the house and found the interference strongest when directly under the wires. The power lines were followed to their termination in the next block at a construction company tool shack. A switch box was located on the wall of the shack. The wires were fed to the switch box through a vertical piece of conduit. From the bottom of the switch box, another short piece of conduit terminated in an outlet box. This lower piece of conduit was grounded. Upon examining the switch box, the writer slammed its door shut. The interference ceased. Moving the conduit caused the interference to reappear. Poor electrical contact between the top piece of conduit and the switch box apparently caused rectification of radio signals. (Fig. 2.) Tightening the conduit to the box cleared the trouble.

Another case of severe station riding occurred with a popular brand multi-tube receiver which was normally quite selective. The receiver was located less than one quarter of a mile from a five-kilowatt broadcast station. This station did not

cause interference, but a ten-kilowatt station fifteen miles away rode every signal that could be tuned in on the broadcast band. The writer tried every trick in the bag including a check of the house wiring. One peculiar condition of this case was the fact that the interference ceased every day between the hours of noon and one P. M., apparently due to load changes on nearby power lines. Since the radio was one of a very popular brand, the distributor was anxious to keep the radio sold, so a factory engineer was dispatched to the scene. He too tried every trick he knew including the replacement of the built-in loop antenna with an antenna transformer and an outdoor vertical rod antenna. Nothing seemed to reduce the interference, so the dealer who had sold the radio exchanged it for one of another make. This receiver worked fine without a trace of station riding. The first receiver used variable capacitor tuning and the second receiver used permeability tuning. However, this proves nothing as in other locations receivers with permeability tuning suffered from station riding just as badly as those with capacitor tuning.

BY-PASSING THE LINE

Still another case. This radio receiver was one of good design with exceptionally good selectivity, but it too suffered from severe station riding. The writer found that running a short ground lead to the grounded side of the A.C. line at the outlet to which the radio was connected completely eliminated the trouble. (The reader should be cautioned not to try this unless he has definitely determined which side of the line is grounded. For safety reasons, a large paper dielectric condenser [2.0 mfd. or larger] should be used in series with the ground lead.) In this case, the cure did not work unless a sufficiently large condenser was used. (See Figs. 3 and 4.) Another word of warning to the reader is to be careful not to violate underwriter rulings.

In cases where the source of interference has been found to be caused by two pipes

(Continued on page 249)

*Assoc. I. R. E.

Characteristics of Electronic Guitars

By ROBERT SMITH



The electric guitar is probably the most popular of electronic music instruments and is universally used.

THE electric guitar is a popular instrument and is used by many "name bands." The serviceman will find it wise to know the circuits used in amplifiers employed for building up the sound of a guitar, as this is one phase of modern electronics which pays off profitably.

The circuit of the Valco Guitar Amplifier is shown in Fig. 1. There are four input jacks. Three of these are in parallel and the fourth works into a separate pre-amplifier tube, a 6J7. This 6J7 functions as a screen-grid amplifier and is VT-1. The output of VT-1 feeds into a grid of the 6N7, VT-3, and the output of this tube, VT-3, drives one of the grids of the 6N7 VT-4. The output of this tube, in turn, drives a 6L6 which works into the loudspeaker.

Tube VT-2 is a 6J7 but is triode connected. The suppressor grid and screen grid are tied to the plate, forming a triode which has a relatively low gain in comparison with a pentode. A low-level mike of the crystal type may be plugged into J-1. A pickup on the guitar may be plugged into J-2, J-3 or J-4. Several pickups can be accommodated if necessary. The 6L6 tubes operate in push-pull. The grid voltages are 180 degrees out of phase. The output of the 6N7, VT-4, plate 1, feeds a signal to the 6L6 grid A through condenser C_a. The signal voltage between grid A and ground causes a signal current to flow in the 100,000 ohm and 4,200 ohm resistors and the voltage across the 4,200 ohm unit is applied to the grid 2 of VT-4. The output of the tube, at plate 2, is fed to grid B on the 6L6 through grid condenser C_b. In this way, using a section of VT-4 as a phase inverter, the out-of-phase relationship necessary for push-pull operation is secured. The output tubes are class-A operated. Volume is controlled by P-1 and P-2. The tone is controlled by means of R_t. Decreasing the

value of R_t cuts the high frequency impedance between the plates of 6N7 VT-3 and ground, causing a reduction in the high frequency response. This tone control may be very necessary and useful in eliminating fringe howl in critical installations where sound bounces off highly reflective surfaces to return to the mike input and cause trouble.

Another typical guitar amplifier is the Vega 180. The diagram is shown in Fig. 2. This amplifier also uses a pair of 6L6 tubes in push-pull class A amplification, giving plenty of audio power output. The same sort of phase inverter system as was employed in the Valco amplifier of Fig. 1 is

also employed in this amplifier. There the similarity ends, for we find that a high gain pre-amplifier system is used, which, incidentally, is a point stressed by the manufacturer in advertising.

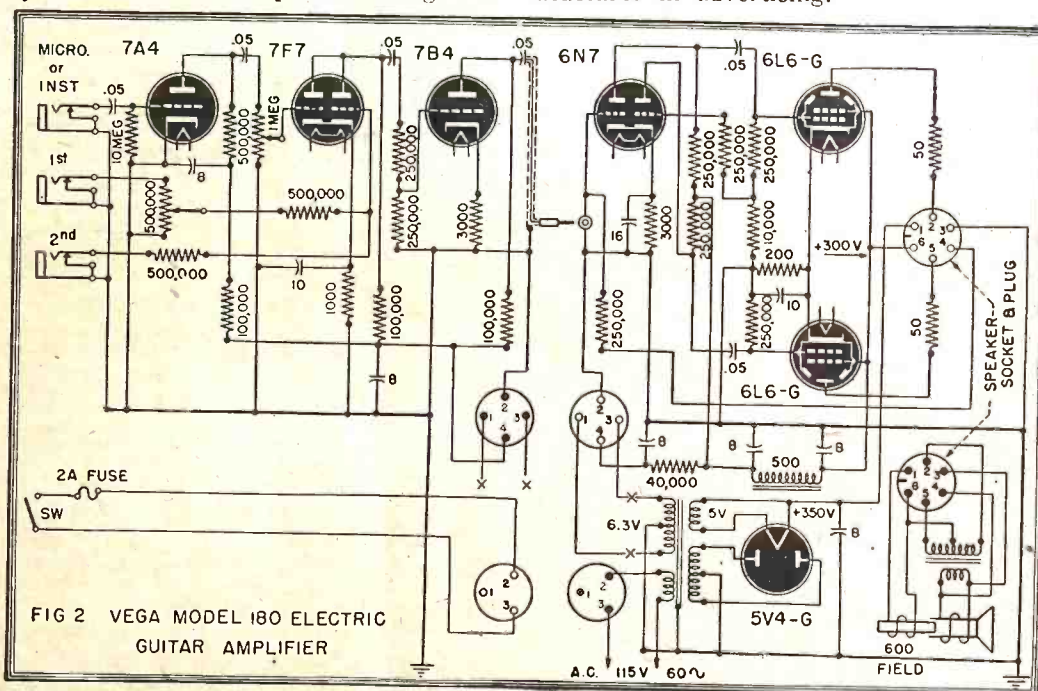

FIG 2 VEGA MODEL 180 ELECTRIC GUITAR AMPLIFIER

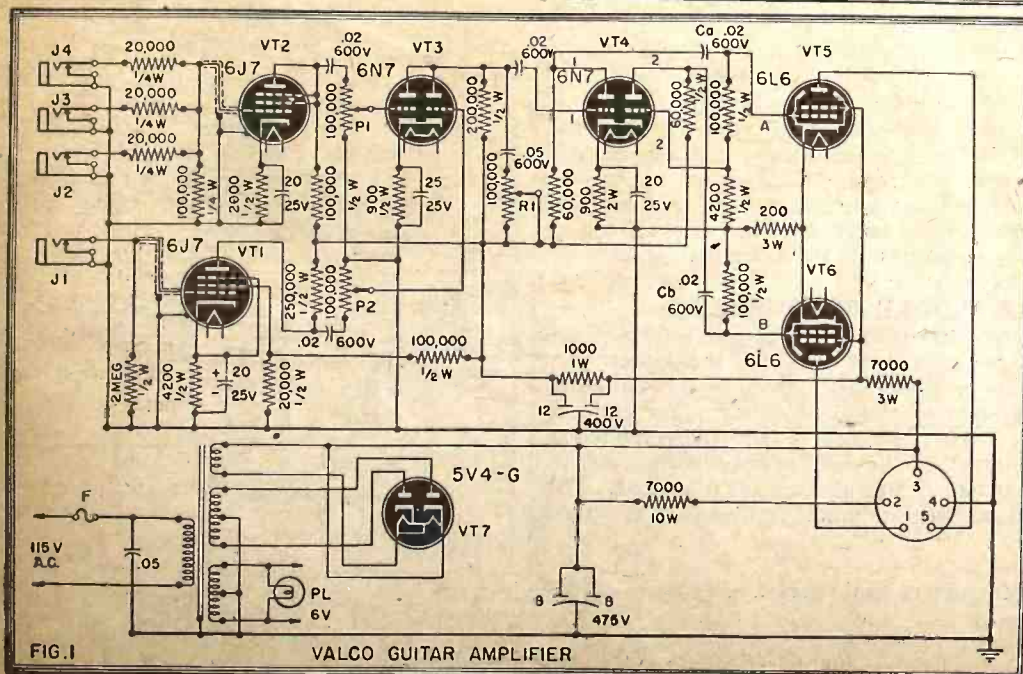

FIG. 1 VALCO GUITAR AMPLIFIER

A low level mike or pickup on a guitar can be fed into the jack marked "micro" or "instr" on the diagram. The signal voltage then is fed to the 7A4 grid. The 7A4 output supplies a signal voltage to the 1 meg potentiometer through the .05 coupling condenser. Thus, the input voltage to the 7F7 grid is adjustable. The output of the 7F7 then drives the 7B4 which works into the 6N7 of the main amplifier. The signal then goes to the 6L6 tubes and the loud-speaker. If the input signal originates at the jack marked "1st," the input level is controlled by the 500,000 ohm control, adjusting the 7F7 grid potential. The output of the 7F7 then follows the sequence previously given. Using the 2nd jack, there is no control of volume and the pickup unit must have its own volume control device.

Low-Wattage resistors used for compactness may break down more than those in larger amplifiers. Otherwise servicing is standard.

(Continued on page 242)

SPEECH AMPLIFIERS

PART IV—TRANSFORMER COUPLED CIRCUITS

By ROBERT F. SCOTT

THE transformer is employed as a coupling method where a step-up in the voltage applied to the grid of the following stage is desired. One advantage of transformer coupling is that the gain may be increased while passing through the coupling device. This is not possible with resistance coupling.

In a transformer coupled stage, the plate of the first tube is coupled to an inductive load. This load is the primary winding of the transformer. The secondary winding is coupled to the grid circuit of the next tube. Due to the transformer, it is possible to have any degree of step-up or step-down between windings. The transformer is adapted to coupling between single-ended and push-pull stages.

A particular disadvantage of transformer coupling is that it has a tendency to accent certain portions of the audio range. This introduces frequency distortion into the circuit. Such distortion is objectionable in practically all cases.

TYPICAL TRANSFORMER CIRCUIT

Fig. 1 is a typical circuit employing transformer coupling between two triode stages. Although quite applicable for construction purposes, a circuit of this type does not include many factors which enter into the operation of the amplifier; as capacitances, inductances and resistances in the circuit. Fig. 2 is the equivalent of Fig. 1.

The average interstage transformer is of the step-up variety. The secondary therefore contains several times the number of

Fig. 1—A standard two-stage transformer-coupled amplifier circuit. Fig. 2—Equivalent circuit of Fig. 1. Figs. 3, 4, 5—How transformer circuits look to intermediate, high and low frequency signals respectively.

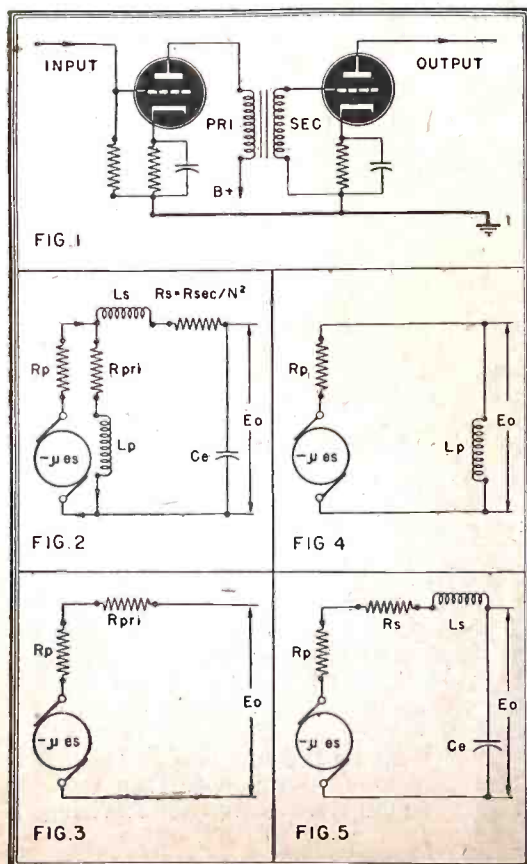

turns found on the primary. The voltage appearing across the secondary depends directly upon the voltage on the primary winding and the turns ratio.

Since each of the windings consists of many turns of wire, each is an inductance. These windings have a very low direct current resistance and there is very little d-c voltage drop across them. When an alternating current passes through the windings, there is a voltage drop across each, due to the impedance of the winding. This impedance will vary directly as the frequency. Since the voltage drop is dependent upon the impedance, we may say that the voltage drop will also vary directly as the frequency of the alternating current. Hence, the voltage drop is lowest at the low audio frequency ranges.

In the equivalent circuit the plate resistance R_p is in series with the load impedance, the primary winding. This combination acts as a voltage divider and the greatest voltage drop appears across the largest resistance. Since for maximum amplification it is necessary to have a maximum voltage across the load, the ratio of the load impedance to the plate resistance should be large.

A factor which is often detrimental to the operation of transformer coupled stages is the distributed capacitance of the windings. This capacitance is due to the potential difference which exists between adjacent turns of the insulated wire in the windings. The sum of these individual capacitances appears across the ends of the inductance.

Since the reactance of a condenser varies inversely as the frequency and the impedance of a coil varies directly as the frequency, the two reactances will be in parallel at high frequencies. The capacitive reactance is then the smaller of the two, much of the high frequency voltage will be shunted around the winding of the transformer. This shunted voltage will have no effect upon the magnetic variation of the core and so the high frequency response will be reduced.

The shunting effect of the secondary winding's distributed capacitance will load the winding due to the transient currents set up in the coil and condenser combination. With the secondary loaded in this manner, the magnetic field set up by the primary is opposed and thus the effective primary inductance is reduced, with consequent reduction of the transformer gain.

THE MIDDLE FREQUENCIES

The intermediate frequencies do not see the complex network of Fig. 2, but only a simple path, Fig. 3, where the inductive reactance of the primary winding and the capacitive reactance of the secondary winding are so large as to present an open circuit. The gain at intermediate frequencies is given by

$$\text{Gain (intermediate frequencies)} = \frac{E_o}{E_s} = uN$$

where E_s = voltage input to first stage

E_o = voltage output from secondary winding
 u = amplification factor of tube
 N = turns ratio of transformer

The relative amplification at low frequencies is governed by the inductance of the primary at these frequencies. The equation for finding the gain at these frequencies is

$$\text{Gain (low frequencies)} = \frac{uN}{\sqrt{1 + (R'_p/6.28 \times f \times L_p)^2}}$$

where R'_p = plate resistance + d-c resistance of primary
 f = frequency
 L_p = primary inductance

Proper application of the above equation will show that when the response falls to 70.7% of uN , the inductive reactance of the plate inductance will be equal to the plate resistance. The equivalent circuit for the low frequencies is shown in Fig. 4.

HIGH-FREQUENCY CALCULATIONS

The performance of the transformer coupled circuit at high frequencies depends upon the individual inductances and the distributed capacitances of these inductances, plus stray capacitances and leakage reactance. The equation for calculating the gain at the high frequencies is rather difficult to handle because many of the factors cannot readily be computed outside (or inside) a laboratory. One of the most simple of these equations is shown below. (See equivalent circuit in Fig. 5.)

$$G = uN \frac{1}{\sqrt{\left(1 - \frac{f_a^2}{f_b^2}\right)^2 + \frac{f_a^2}{f_b^2 \times Q^2}}}$$

where f_a = frequency of operation
 f_b = resonant frequency of the series circuit consisting of total leakage inductance and the distributed capacitance

$$= \frac{1}{6.2832 \times \sqrt{L_t \times C_o}}$$

L_t = the sum of the primary and secondary leakage inductances divided by the turns ratio squared
 $= L_p + L_s/N^2$

and $C_o = (C_m + S_s + C_L) \times N^2$ farads
 Q = is the ratio of the reactance of the series circuit to its effective series resistance
 $= \frac{6.2832 \times f_b \times L_t}{R_p + R_{pri} + R_{sec}}$

where R_p = plate resistance
 R_{pri} = resistance of the primary winding
 R_{sec} = resistance of the secondary winding

EMERGENCY OHMMETER

By A. P. NIELSEN

THIS ohmmeter was built from what was found at the very bottom of the junk box, and worked so well that it was deemed worth passing on to others. If the builder has an 0-1 milliammeter, he can construct a higher-range instrument than the one shown, and need read no further. If he has not, almost any kind of low-range voltmeters or milliammeters will do fair work in the circuit given. I have built several, using meters not over 7½ volts D.C. and not over 25 millamps D.C. Almost any kind of transformer on hand can be used, too.

If a low-range meter is used—especially a low-range milliammeter, it must be protected by placing a suitable resistor in circuit. This resistor should be of such a size that the meter just reads full-scale deflection when the terminals X,X, are shorted. In this particular circuit only a single 10,000-ohm resistor was found necessary to prevent overloading the meter, and this was needed only in the lower ranges. Since measurements take only a short time, a 1-watt resistor was big enough here.

An old filament transformer was used, with a 71-A tube hooked up as a half-wave rectifier (grid and plate tied together). The 71-A gave much better results than any other type of 5-volt tube tried, and apparently, a tube for this job must be one with a low internal resistance. The condenser across the D.C. line also had an effect, any larger or smaller size than the 0.1-mfd. unit used would lower the high range of the meter.

The meter I use is an old Jewell 0-5-volt type. The transformer was from an old Kodak Dry B replacement unit, together with its 4-prong socket. Its filament winding had a center tap, but of course if there had not been a center tap I could have attached the positive lead direct to one side of the filament.

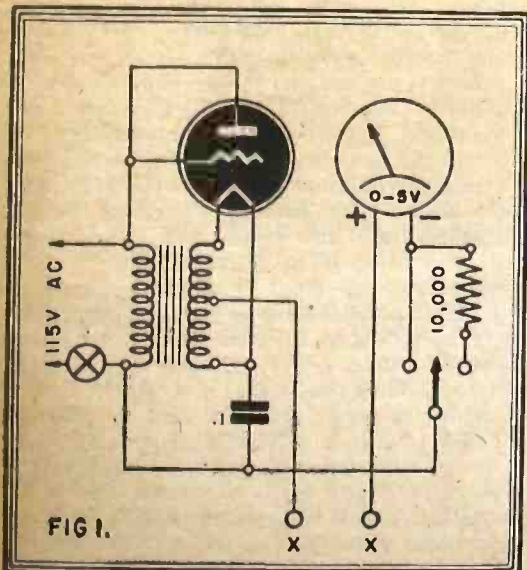

FIG. 1.

Fig. 2-a, the low-range circuit, which I stumbled across accidentally while trying out another, looked familiar, so I dug into my reliable storehouse of former days, the stack of filed *Radio-Craft*. The circuit sought was on page 282 of your November 1932 issue, in an item submitted by Mr. George H. Gabus. His circuit—Fig. 2-b—is better than mine, except that mine can be clipped together anywhere. Just use a battery big enough to make the meter read full-scale with test leads open, not shorted this time. If you have a milliammeter instead of a voltmeter, enough resistance will have to be inserted in series so that the meter will read just full-scale with the battery used. It then becomes practically the Gabus circuit, except that there is no adjustment for a failing battery.

With the above circuit I can make accurate measurements from 20 ohms to 1

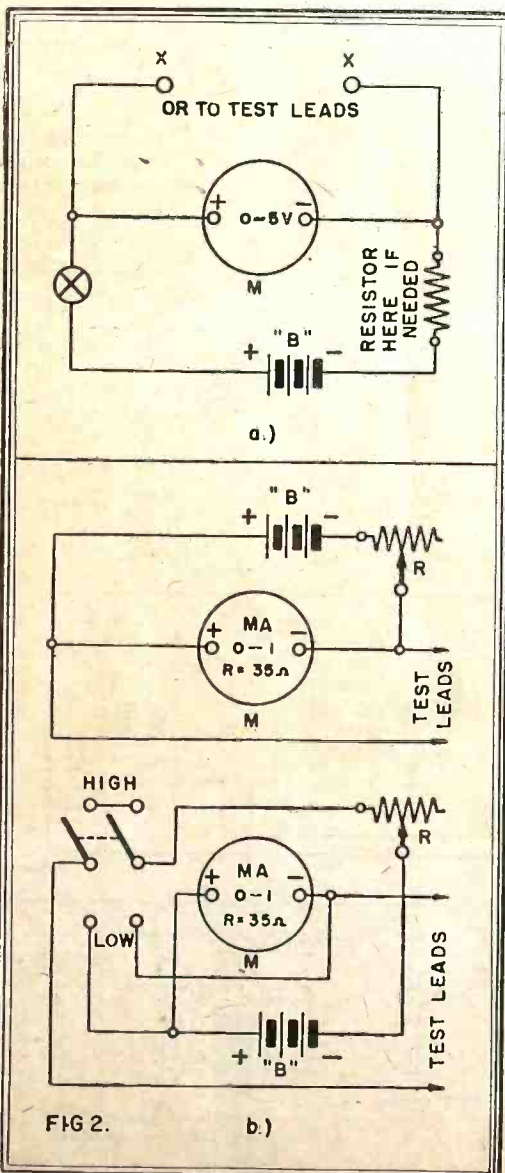
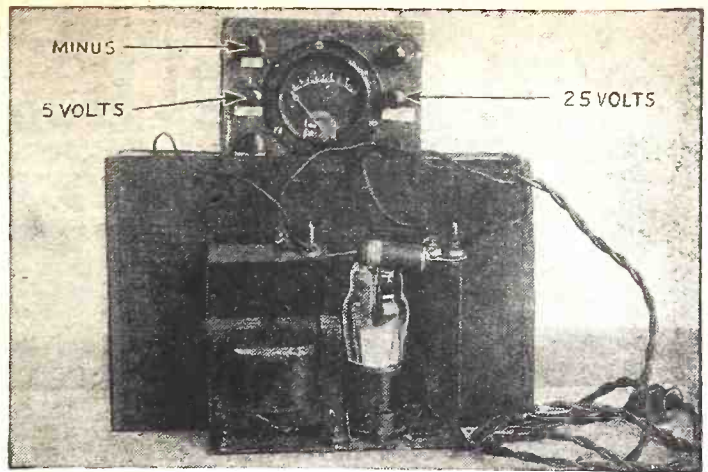

FIG. 2.

b.)



Meter sits on the box which holds tube and transformer.

megohm, and 1.5 and 2 megohms can be identified. All the parts, except the separate meter, are neatly housed in a 3½ x 7½ x 11-inch wooden box, with a removable upper lid. The scale for the low range meter was calibrated from an old variable rheostat and two higher scales, one for A.C. and one for battery use, from new fixed resistors. Scales were made on graph paper, to save spoiling the face of the meter.

SCANNING THE BRAIN WAVE

ELECTRICAL engineers who have solved the scanning problem in television could help solve the technical problems now hampering scientists trying to unravel the mechanism of mental activity through study of the electric potentials of the brain, Dr. R. W. Gerard, physiologist of the University of Chicago, declared at the recent National Electronics Conference.

"Only lack of suitable instruments," he said, "prevents the plotting of every single message which travels anywhere in the brain." The philosophical arguments over whether man has a free will might some day be settled by physical measurements of electrical activity in the brain, he hinted.

By all means the most dramatic thing about the brain waves is that they exist with the subject at rest and are actually fragmented by activity. The main, or alpha, rhythm is most pronounced in a person sitting relaxed in a dark room. Mental effort, mild emotion, or sensory stimulation, especially by light, disrupts it. Experiments on other animals, notably the frog, prove what the human observations suggest; that the brain has a spontaneous electrical beat, as automatic as that of the heart, which is modified by but not dependent on outside stimulation.

This major discovery has changed our thinking about the brain: from the picture of a passive telephone system which is inactive unless receivers are up, to one of a system in continuous activity and able to start its own messages as well as to receive others. This does not yet quite make a place for free will but it does fit better the facts of conscious experience.

Among problems still to be solved is how metabolic energy is transformed into rhythmic membrane potential waves. The membranes which surround all living cells, Dr. Gerard explained, are differentially permeable to ions and become polarized or charged as condensers. They are kept charged, commonly to about 50 millivolts, by energy released in the course of metabolism, mainly by the oxidation of sugar.

"The myriad cells, arranged in fairly regular layers in the brain cortex, beat in synchrony to a large extent—it is only then that the brain waves are ordinarily measurable—but also form special activity patterns and are modulated by incoming nerve signals," Dr. Gerard stated.

Fig. 1—The simple ohmmeter, made from parts at hand. Fig. 2-a—A low-range circuit, which operates better with a milliammeter than the voltmeter shown. Fig. 2-b—The Gabus circuit.

A Magnetic Recorder

Uses Recent Supersonic Method for Wire Recording

By WARREN M. DAVIS

A MAGNETIC wire recorder, an electronic machine for recording voice and music on wire about the size of a human hair, is one of the post-war "wonders" that most any radio amateur or repairman can build from the spare parts laying around his shop. The principle involved in wire recording is not new. It was invented in 1898 by

Valdemar Poulsen, a Danish scientist, and since then has been improved and simplified. Wire recording has been more extensively used in Europe than in America. The machine can be used

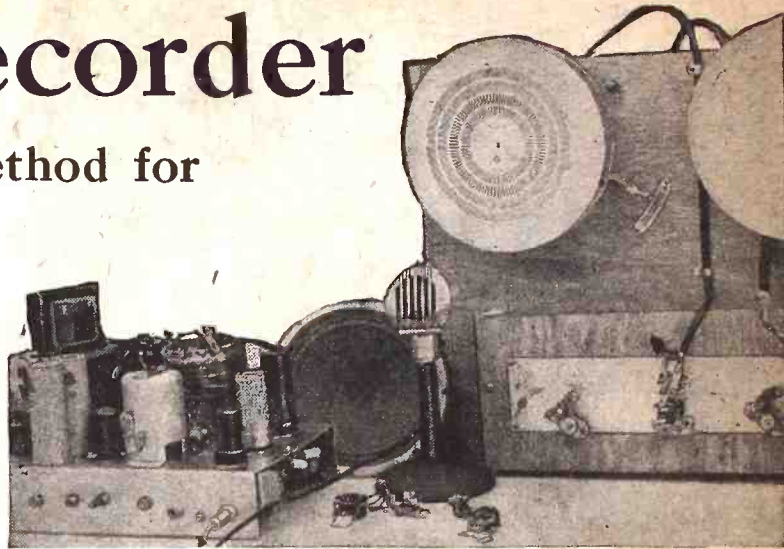

The author's experimental set-up. The stroboscope speed gage is permanently attached to one of the wire reels.

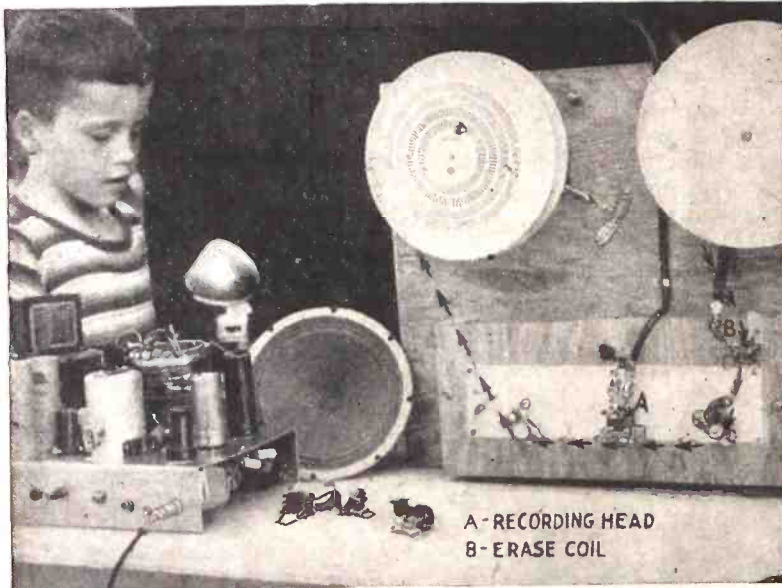

for office dictation, making oral notes in a laboratory, recording pilot's weather observations, as well as home entertainment.

I have my own radio shop tucked in the east end of my cellar at my home on Mill road in North Hampton, N. H. For quite a while I had fancied making a magnetic wire recorder but with all the war shortages on

radio parts it looked impossible. On the start of my vacation the other day I was struck with the idea that the junk box—bulging with old spare parts—was the answer to my material shortage. It was! Every radio amateur or repairman know has the same kind of a box so they have the essential parts needed to build their own magnetic wire recorder.

The amplifier used may be any conventional circuit capable of 5 to 10 watts output with a few modifications and the addition of a low frequency oscillator. The oscillator may be on a separate chassis if necessary. The recording head, which is also the reproducer, can be constructed from old audio transformer laminations which must be filed to fit the coil being used in the head. The coil can be found in old magnetic phonograph pick-ups or magnetic speakers.

The wire puller, the spool that winds the wire, is best powered by an old electric phonograph motor. The spools or reels on which the wire is wound can be cut out of solid wood or laminated boards. The wire guides should be of non-magnetic material such as pulleys taken from old radio dial assemblies. These components may be mounted in any number of ways to suit the individual builder.

The wire used for recording must be a steel wire with 5- to 9-tenths of one per cent carbon content. I have used piano wire .014 inch in diameter and smaller. The smaller the wire the better the quality.

I made the amplifier first. So from now on I'll discuss the building of this machine piece by piece. In the bottom of my junk box I found an old radio chassis which measures 10 by 16 by 3 inches. First I built the power supply which consisted of a power transformer capable of delivering 120 mills at 350 volts DC. Then I built a conventional line-of-four-tubes amplifier following. The only difference in this amplifier from conventional circuits is the addition of an audio filter inserted between the pre-amplifier and the driver tube. The purpose of the filter is to attenuate the low frequency audio signal. This filter consists of a resistance-capacity-inductance network.

The resistor is connected between the second stage coupling condenser and the driver. This consists of two 4,000 ohm resistors in series shunted with an .006 condenser, with a 125 millihenry choke connected from between the 4,000-ohm resistors to ground through a variable 25,000-ohm control. There is a switch between this control and ground. It is followed by a second identical network. A second coupling condenser isolates the filter from the grid of the following tube. This filter is used only

(Continued on page 236)

Left — Recording on the magnetic wire. Arrows show direction of wire travel.

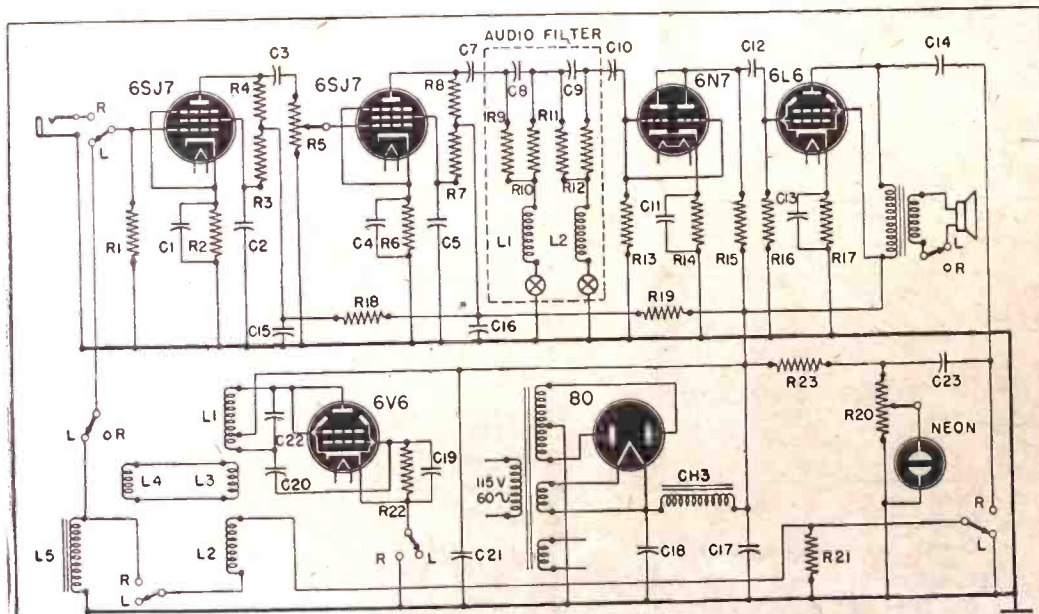

FIG 1

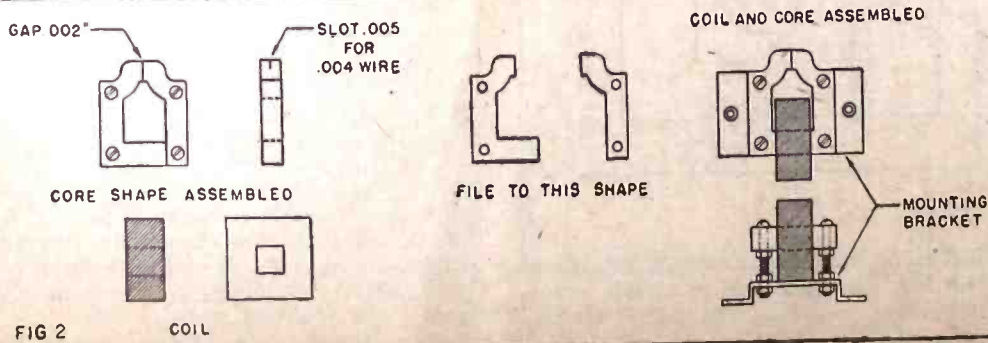

FIG 2

New Radio-Electronic Devices

COMMUNICATIONS MICROPHONE

Electro-Voice Mfg. Co.
South Bend, Ind.

DESIGNED for police, airport, utility, mobile communications and portable public address installations, the 600-D Electro-Voice microphone is produced to meet rigid war-time specifications.

Among the many features of the new 600-D, is the "press-to-talk" switch which opens the microphone and closes the relay simultaneously, if desired. A high impact molded phenolic case built to requirements of rugged military usage weighs but 9 ounces. Resistant to temperature changes, this communications microphone will withstand temperatures from -40 to +185 degrees F. The frequency response of the 600-D ranges from 50 to 8,000 cycles per second with an output of -57 DB. (0 DB. = 1 volt/Dyne/CM²). The curve is substantially flat for highest articulation. Complete with an 8-foot cable, a panel mounting bracket is on the rear of the microphone.—*Radio-Craft*



3,000-VOLT DYNAMOTOR

Carter Motor Co.
Chicago, Ill.

THE unit is 11½ inches long 4½ diameter and 5 inches high and weighs less than 18 pounds without filter. It furnishes 3,000 volts D.C. at 0.05 amperes. The input to the motor portion of the dynamotor can be had in voltages ranging from 12 volts to 115 volts D.C.

Special laminations and special type insulation which is capable of withstanding the very high voltage without

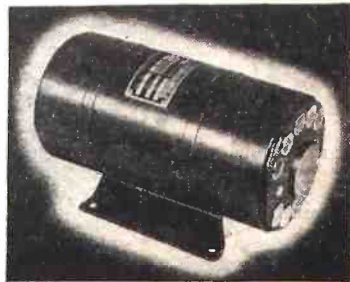

SEALED INSULATING LEADS

Electrical Industries, Inc.
Newark, N. J.

ELECTRICAL Industries hermetically sealed leads are constructed of pyrex glass with Kovar electrodes and Kovar metal collars. The Pyrex glass assures high dielectric strength, immunity to any reasonable thermal or mechanical shock as well as absolute freedom from absorption of moisture and humidity. The surface of the glass insulator is such as to provide maximum water shedding properties and accounts for the high performance of the insulator.

The electrode and collar are ideal materials for soldering,

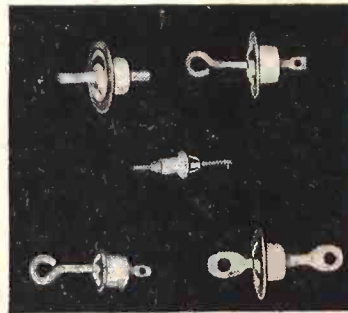

breakdown are found in this unit. Also, it is possible to furnish it with two 1,500-volt, 0.05 ampere outputs, instead of the 3,000-volt one. Because of the high voltage and the tendency toward sparks and corona effects, the ends of the unit, where the brushes are located, are enclosed in explosion-proof covers, enabling its use in gaseous locations such as near airplane engines, in mines and other similar positions where contacts might be dangerous.

It is expected that the units will be used in portable television equipment, portable-high-voltage visual signaling devices and portable and mobile equipment.—*Radio-Craft*

DUAL-UNIT ATTENUATOR

The Daven Co.
Newark, N. J.

THE Daven Dual-Unit construction finds most important application in Balanced "H" Attenuators, as well as in special multi-circuit controls of the Potentiometer, "T", Ladder, "L", and Rheostat types. Comprised of two units, one mounted behind the other, the respective shafts of each meet in a lap joint within a long snug bushing, providing quick and easy separation of the units. This is done by simply loosening a knurled nut and releasing a snap-on fitting, without the necessity of dismantling the front unit from the instrument panel.

The new Dual-Unit model is electrically the same as previous models. In addition it has fungus and mildew resisting varnish on all bakelite parts and resistive windings. Contact and switch blades are of tarnish resistant, improved silver alloy. Other metals are optional. The means of coupling front and rear attenuator shafts is simple, positive, durable and foolproof.—*Radio-Craft*

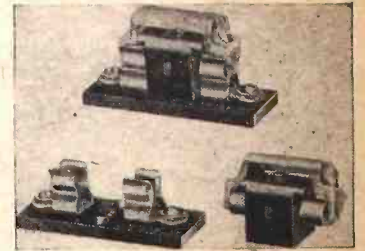
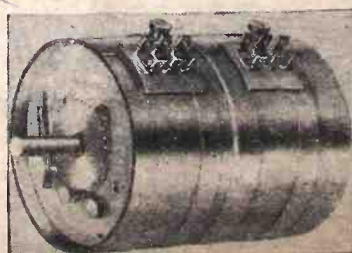

Shield can be swung aside for resetting, the Breakerette being removed from the clips. In the nontrip-free the shield is not used.

The Breakerette is extremely small and light and no more affected by ambients than fuses. There are only two moving parts. Case is molded bakelite. Trip-free shield is of thermoplastic to permit visual indication when breaker is tripped. Extreme dimensions 1⅞ inches long x ¾ inches wide. Overall height with trip-free shield is 1½ inches. Weight 15 grams without hood, 18 grams with hood. It fits into clips on ⅞ inch spacing or more.—*Radio-Craft*

TROPICALIZED RESISTORS

Instrument Resistor Co.
Little Falls, N. J.

A complete line of resistors providing two-way protection against deterioration and resultant failure in tropical or humid locations now is available. Each component is enclosed in a special bakelite case. After complete dehydration the resistor is carefully sealed in a special compound, and further made impervious to atmospheric surroundings with a bakelite cap which is accurately machined to fit the bakelite case. Leads are bare at the point of entrance through the case, and are permanently and hermetically sealed with special tropicalizing compound.

No creepage of moisture or fungus growth can take place at any point. Corrosion, electrolysis or oxidation are effectively barred from the resistor unit by this effective method of enclosure. A 6-32 mounting screw is an integral part of the housing. After completion of the unit, a special fungicidal coating is applied. This coating is non-toxic, meets all Signal Corps No. 71-2202-A specifications and is effective for about one year after application.—*Radio-Craft*

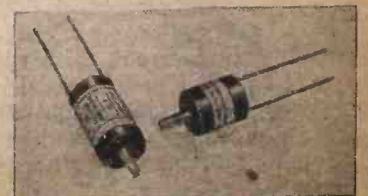

brazing or welding to the unit enclosure. Standard shapes and sizes are available in a wide variety of shapes for standard applications. Any shape or size can be furnished to meet particular requirements and the most exacting specifications.

The Pyrex glass and metal electrodes form an absolutely gas and moisture tight chemical bond, so that internal gas pressure may be maintained in units employing these leads. This bond likewise defies the stress and strain of severe temperature change.—*Radio-Craft*

LITTELFUSE BREAKERETTE

Littelfuse Inc.
El Monte, Calif.

RESET protection in circuit breaker form, interchangeable with all 5 A G fuses, or Navy "midget" size, both for new equipment and replacement, is one of the latest products of Littelfuse, Incorporated. (5 A G fuses: 1½" x 13/32" dia., 3 to 50 amperes.)

The new No. 1561 Breakerette is of push breaker type, rated at 32 volts A.C. or D.C. Break is snap action capable of interrupting short circuits of 1000 amperes in ratings up to 5 amperes and 2500 amperes in ratings over 5 amperes capacity.

Both trip-free and nontrip-free features are provided—the trip-free by a shield attached to end caps, and pivoting on them.

World-Wide Station List

Edited by ELMER R. FULLER

WE appreciate the response we have had during the past year to our appeals to short-wave fans to join our ranks and send us the dope that they dig up from the ether. It is hoped that they will continue to send us reports and that during the coming year we will be able to add still more names to our list of observers.

Due to shortage of space and the impossibility of reducing our station list to any great extent, we have taken the next step and beginning with this issue, will use smaller type for the station list. Also many stations we have listed for several months, but have not been reported as being now on

the frequency given, will be omitted. If you find we have dropped one which should have been left in the list, please let us know about it.

A new Cuban is being heard in the morning, CMCY on 11.68 megacycles; location of course, is Habana. VJY9, on the Island of Curacao, is being heard frequently on 9.31 megacycles. The transmitter on 10.065 megacycles is in Cairo, Egypt, and is being heard afternoons. The Swiss have left the frequency of 9.185 megacycles. Another new Cuban is being heard on 9.270 megacycles during the evenings.

TAP, in Ankara, Turkey, is being heard daily at 1 to 2 p. m. on 9.51 megacycles with

very good results in the eastern United States. CSW6 in Lisbon, Portugal, has been heard several times recently coming in on 11.04 megacycles during the afternoon, usually around 3 p. m.

In an early issue we will bring to you a chart showing the stations most often heard and the times that they are on. This will give you a quick way of telling what to listen to or for at any given hour. It is now in preparation, and it is hoped that it will be ready for publication in the February issue. If you have any other practical suggestions, let's hear from you.

All times mentioned in this magazine are always Eastern War Time.

Freq.	Station	Location and Schedule	Freq.	Station	Location and Schedule	Freq.	Station	Location and Schedule
These are additions to last issue of part 1 of log.			9.608	ZRL	CAPE TOWN, SOUTH AFRICA; 10 to 11:45 am.	9.720	PRL7	RIO DE JANEIRO, BRAZIL; 4:10 to 9:50 pm.
5.400	YDRI	NETHERLANDS INDIES; heard about 3 am.	9.610	DXB	BERLIN, GERMANY; evenings.	9.730	XGOA	CHUNGKING, CHINA; 1:30 to 2:40 am; 6:30 to 10 am.
6.180	XGEA	CHUNGKING, CHINA; girl announcer at 10:30 and 11:30 am.	9.610	ZYC8	RIO DE JANEIRO, BRAZIL.	9.735	CSW7	LISBON, PORTUGAL; heard 9 to 10 pm.
7.12	GRM	LONDON, ENGLAND; heard at 2 am in Pacific service.	9.615	TIPG	SAN JOSE, COSTA RICA; heard at 9 pm.	9.735	CXA15	MONTEVIDEO, URUGUAY.
7.150	---	LONDON, ENGLAND; South America service.	9.615	VLC6	MEXICO CITY, MEXICO; heard at 7:25 pm.	9.740	CSW7	LISBON, PORTUGAL; heard 9 to 10 pm; is probably same transmitter as on 9.735 but checks at different points on different days.
7.320	---	LONDON, ENGLAND; heard evenings.	9.625	---	MELBOURNE, AUSTRALIA; heard at 8:30 and 11 am.	9.740	---	"RADIO FRANCE"; heard 4:30 to 4:50 pm.
This is new copy of part 2 of log.			9.630	CBFX	LONDON, ENGLAND; South American service.	9.760	DKSA	"DEUTSCHER KURZWELLEN SENDER ATLANTIK."
9.100	ICA	NAPLES, ITALY; heard at 10:45 pm.	9.640	GVZ	MONTREAL, CANADA; heard going off at 12:06 am.	9.785	OTC	LEOPOLDVILLE, BELGIAN CONGO; relays BBC from London evenings.
9.120	---	BALIKPAPAN, BORNEO; heard 6 to 7 pm.	9.64	KZRH	LONDON, ENGLAND; heard at 2:30 am in Pacific service.	9.800	DKSA	"DEUTSCHER KURZWELLEN SENDER ATLANTIK"; heard from 2:30 pm on.
9.125	HAT4	BUDAPEST, HUNGARY.	9.646	XGOY	MANILA, PHILIPPINES; 6 to 7 am.	9.825	GRH	LONDON, ENGLAND; heard at 9:50 pm.
9.270	---	HAVANA, CUBA; heard early evenings.	9.650	DJW	CHUNGKING, CHINA; East Asia and South Seas beam, 7:35 to 9:40 am; North American beam, 9:45 to 11:40 am; European beam, 11:45 am to 12:30 pm; East Asia and South Seas beam, 12:30 pm to 1:45 pm.	9.855	KWIX	SAN FRANCISCO, CALIFORNIA; Australian beam, 4 to 6:30 am.
9.31	VJY9	CURACAO, NETHERLANDS WEST INDIES.	9.650	WOOC	NEW YORK CITY; European beam, 5:15 to 6:45 pm; 7 to 9:15 pm.	9.897	WKRD	NEW YORK CITY; European beam, 9 to 11:30 pm; 2:15 to 6 am.
9.360	CBFX	MONTREAL, CANADA; 7:30 am to 11:30 pm.	9.660	---	LONDON, ENGLAND; heard at 8:50 pm.	9.897	KROJ	LOS ANGELES, CALIFORNIA; Australian beam, 4 to 9 am.
9.410	---	LONDON, ENGLAND; to South America.	9.670	WNBI	NEW YORK CITY; European beam, 4 to 7:30 am; 3:45 to 5:15 pm.	9.897	WKRX	NEW YORK CITY; North European beam, 6 to 8:45 pm.
9.440	FZI	BRAZZAVILLE, FRENCH WEST AFRICA; heard about 4:30 pm.	9.670	WRCA	NEW YORK CITY; Brazilian beam, 8 to 11:30 pm.	9.930	---	ATHENS, GREECE; heard 2 to 7 pm.
9.465	TAP	ANKARA, TURKEY; heard at 4:15 to 4:45 pm in English.	9.680	XEQQ	MEXICO CITY, MEXICO; heard at 8:48 pm; sked not known.	9.930	DKSA	"DEUTSCHER KURZWELLEN SENDER ATLANTIK"; heard from 2:30 pm on.
9.490	---	LONDON, ENGLAND; European service.	9.685	TGWA	GUATEMALA CITY, GUATEMALA.	9.950	---	NBC IN LONDON, ENGLAND; no sked followed.
9.490	WCBX	NEW YORK CITY; Brazilian beam, 5 to 11:30 pm.	9.690	GRX	LONDON, ENGLAND; North American beam, 5:15 to 10:15 pm.	9.958	HCJB	QUITO, ECUADOR; 9 to 9:45 am; as late as 11:20 pm.
9.490	KRCA	SAN FRANCISCO, CALIFORNIA; Oriental beam, 2 am to 12:30 pm.	9.693	JIE2	TAIHOKU, FORMOSA.	10.000	WWV	WASHINGTON, D. C.; U. S. Bureau of Standards.
9.490	WCBN	NEW YORK CITY; European beam, 2:15 to 3:30 am.	9.700	WRUW	BOSTON, MASSACHUSETTS; European beam, 2:15 to 4 am.	10.040	---	BERLIN, GERMANY; heard evenings till about 9 pm.
9.500	WOOC	NEW YORK CITY; heard testing.	9.700	WRUS	BOSTON, MASSACHUSETTS; Central American beam, 7:30 pm to 2 am; North African beam, 6 to 7:30 am; 8:15 to 7:15 pm.	10.050	SUV	CAIRO, EGYPT; heard calling New York occasionally, usually Sundays.
9.500	XEWV	MEXICO CITY, MEXICO; 9 am to 3 am.	9.700	WRUA	BOSTON, MASSACHUSETTS; North African beam, 4:45 to 6 pm.	10.065	---	CAIRO, EGYPT; heard afternoons.
9.510	TAP	ANKARA, TURKEY; 1 to 2 pm.	9.705	---	FORT DE FRANCE, MARTINIQUE; thought to be heard at 8:36 pm.	10.080	---	MADRID, SPAIN; heard calling New York.
9.510	GSB	LONDON, ENGLAND; on at 2 pm.				10.130	HH3W	PORT AU PRINCE, HAITI; heard afternoons and evenings.
9.520	---	COPENHAGEN, DENMARK; heard 8 to 11 pm.				10.22	PSH	RIO DE JANEIRO, BRAZIL; evenings.
9.525	---	LONDON, ENGLAND; European service.				10.290	---	BERLIN, GERMANY; no sked known.
9.530	WGEO	SCHENECTADY, NEW YORK; East South American beam, 5:30 pm to midnight.				10.338	---	BERN, SWITZERLAND; North American beam, 3:45 to 4:15 pm except Saturdays; to South America, 7:30 to 9 pm.
9.530	WGEA	SCHENECTADY, NEW YORK; European beam, 8:15 to 8 am.				10.400	YPSA	SAN SALVADOR, EL SALVADOR; heard evenings.
9.530	KGEX	SAN FRANCISCO, CALIFORNIA; Oriental beam, 5 to 10:45 am.				10.543	DZD	BERLIN, GERMANY; evenings.
9.535	JZI	TOKYO, JAPAN; noon to 1:45 am.				10.620	KES3	SAN FRANCISCO, CALIFORNIA; N. E. I. beam, 1 to 6:30 am.
9.539	---	BERN, SWITZERLAND; heard evenings.				10.840	KWV	SAN FRANCISCO, CALIFORNIA; Australian beam, 2 to 5:15 am; N. E. I. beam, 5:30 to 7 am; 4:30 to 6 pm; Sundays only, 4:45 to 6 pm; off on Wednesdays.
9.540	VLG2	MELBOURNE, AUSTRALIA; heard at 8:30 and 11 am.						The following are additions and corrections to part 3 which was published two months ago, and which will be repeated in full in the next issue.
9.540	VE9AI	EDMONTON, CANADA; heard evenings; no sked yet.				11.68	GRG	LONDON, ENGLAND; heard on at 11 am and 12:30 pm.
9.540	---	BERLIN, GERMANY; evenings till after 11 pm.				11.740	COCY	HAVANA, CUBA; heard at 1 and 5 pm; probably on all afternoon.
9.550	WGEX	SCHENECTADY, NEW YORK; European service, 5 to 9 pm.				11.780	---	LONDON, ENGLAND; heard at 1 pm and 7 to 10 pm.
9.550	---	SINGAPORE, STRAITS SETTLEMENTS; heard at 7:25 to 7:30 am.				11.780	---	PANAMA CITY, PANAMA; heard at 1:15 and 9:30 pm.
9.550	QWB	LONDON, ENGLAND.				12.040	GRV	LONDON, ENGLAND; heard at 11 am and 1 pm.
9.555	XETT	MEXICO CITY, MEXICO.				12.070	CSW	LISBON, PORTUGAL; heard 2:30 to 4 pm.
9.560	---	BERLIN, GERMANY; evenings till after 11 pm.				14.800	WQV	NEW YORK CITY; Sundays only, 3:30 to 4:30 pm.
9.565	---	MOSCOW, U.S.S.R.				15.11	DJL	BERLIN, GERMANY; opens at 11:10 am to Africa.
9.57	KWIX	SAN FRANCISCO, CALIFORNIA; Oriental beam, 6:45 to 10:45 am.				15.155	SBT	STOCKHOLM, SWEDEN; heard at 11 am.
9.570	KWID	SAN FRANCISCO, CALIFORNIA; South American beam, 8 pm to 12:45 am.				15.260	GS1	LONDON, ENGLAND; heard at 11 am.
9.570	WBDS	BOSTON, MASSACHUSETTS; European beam, 3:45 to 5:30 am.				17.850	---	BERLIN, GERMANY; heard at 10:30 am.
9.580	GSC	LONDON, ENGLAND; North American beam, 5:15 pm to 12:45 am.						
9.58	VLG	MELBOURNE, AUSTRALIA; 11 to 11:45 am.						
9.590	WCRC	NEW YORK CITY; European beam, 4 to 6:45 am.						
9.59	WLWO	CINCINNATI, OHIO; West South America beam, 7 pm to mid.						
9.595	---	ATHLONE, IRELAND; heard at 5:10 to 5:30 pm.						
9.600	XAEW	MEXICO CITY, MEXICO; heard late afternoons and evenings.						
9.600	GRY	LONDON, ENGLAND.						

Technical Terms Illustrated

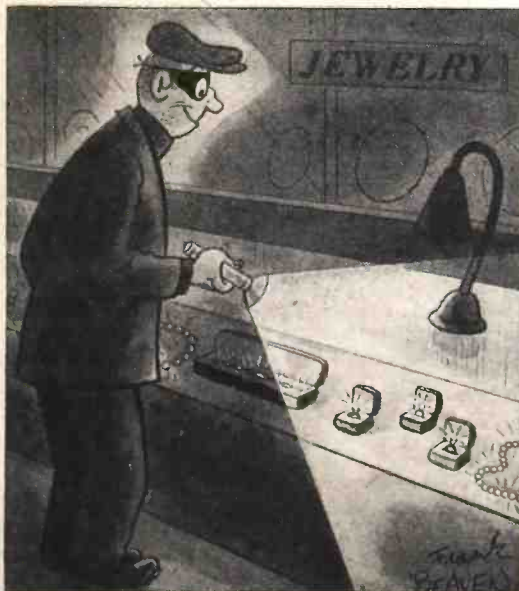

Suggested by: Steve Elco, Linden, N. J.
"A Crystal Detector"

Radio-Electronic Circuits

MULTI-USE INDICATOR

This indicator has a large number of uses. It can be added to a one-tube set as a tuning indicator and will amplify the signal as well. It may be inserted between the detector and power tube to act as a voltage amplifier and indicator.

It may also be attached to an amplifier or recorder as a volume indicator.

EDWIN BOHR,
N. Chattanooga, Tenn.

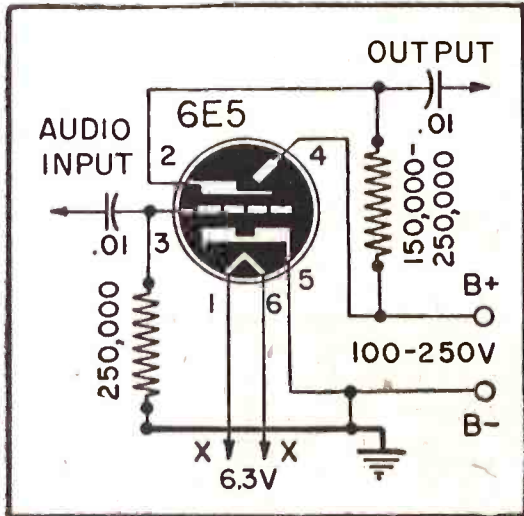

AC-DC INTERCOMMUNICATOR

This intercommunicator gives excellent results up to fifty miles. It is self-contained and was designed for use by signalmen to communicate between interlocking towers and signal locations over available telephone lines.

When S-1 is in normal "listening" position, the low-impedance windings coupling T-1 to T-2 are shorted and simultaneously the speaker is connected to the output secondary. When S-1 is depressed the speaker is connected in series with the above two low-impedance windings to transmit sounds over wires.

Components are marked and impedance of transformers is designated. Better re-

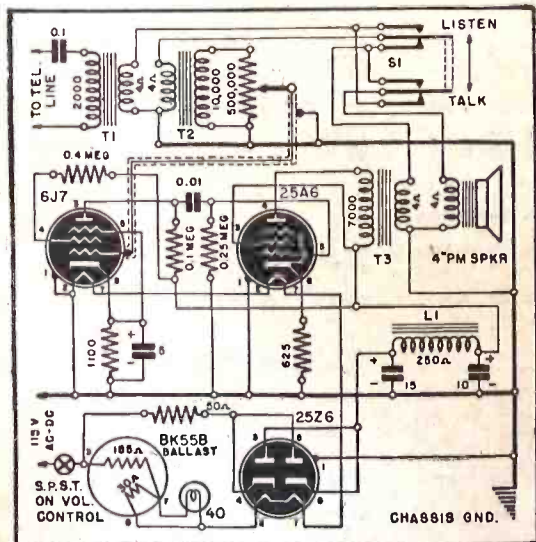

sults would probably have been obtained had it been possible to obtain a transformer with 600 ohms impedance facing the open line for T-1. This not being obtainable, an ordinary Jensen output transformer (ZP-1020) was used for it as well as T-2 and T-3.

P. A. FLANAGAN,
Richmond, Va.

RADIO-CRAFT welcomes new and original radio or electronic circuits. Hook-ups which show no advance on or advantages over previously published circuits are not interesting to us. Send in your latest hook-ups—RADIO-CRAFT will extend a one-year subscription for each one accepted. Pencil diagrams—with short descriptions of the circuit—will be acceptable, but must be clearly drawn on a good-sized sheet of paper.

OSCILLATOR AND TESTER

I have built this excellent servicing tester using only a 1-V, a 76 and a 2-watt neon bulb. The line resistor may be either a 360-ohm 10-watt unit or a 40-watt bulb. Grid and plate coils are wound for desired bands.

C4 and C5 are capacitances formed by merely twisting a pair of leads about 2 inches long. I obtain a loud R.F. signal which has a high-pitched musical tone, the single 1 MFD condenser giving just the right amount of filtering.

Condensers to be tested (at C terminals) must have a peak voltage rating of at least 120 volts. The neon indicates if leakage is present.

HENRY J. RUTOWSKI,
Detroit, Michigan.

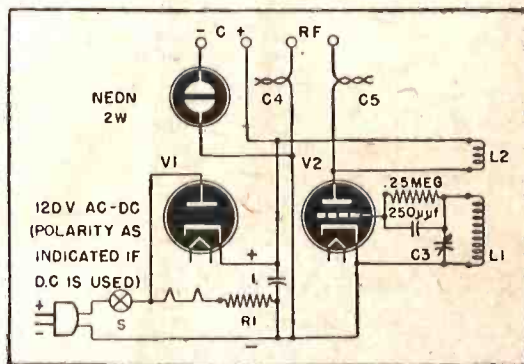

CARRIER CURRENT

The transmitter circuit is shown in the diagram. The oscillator coil is an I.F. tapped coil. For elimination of key clicks the filter may be connected as shown. The I.F. oscillations are then transmitted to the line through .02 mfd. condensers, the line being a power line, telephone line, or other available wires.

To receive it is only necessary to couple the line again through .02 condensers to the I.F. first stage of a superheterodyne receiver. It is necessary to use a B.F.O. in the receiver to hear the code signals. It is also possible to modulate the oscillator with phone in which case no B.F.O. is required in the receiver.

RICHARD COLE,
Orange, Texas.

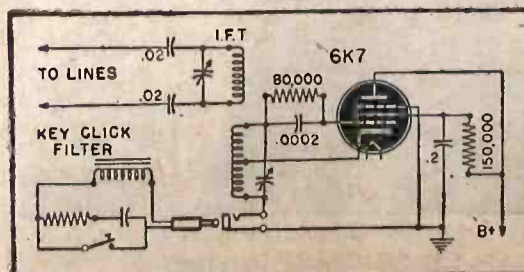

ONE TUBE SET

This small one-tube receiver works as well as much larger radios. I find that either a type 30 or a 1E4 are the best tubes to be used in this circuit. The tuning coil may be of the type used on crystal sets, using a slider to tap off the desired number of turns. Of course, a tuning condenser may be used.

I find that better results are obtained after the dry cell has run down a little than when it is new, so you don't have to

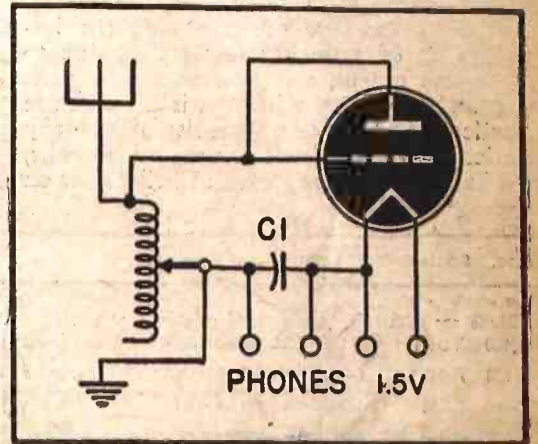

worry about batteries. C1 is not critical, about .002-.00005 being good.

PHILIP DENNISON,
Salina, Kansas.

(This set will be no louder than a good crystal receiver, but will free the user from the problem of spot-hunting and maintaining adjustment.—Editor)

CONDENSER CHECKER

This capacity bridge can be built very quickly and solves the problem of a variable-voltage transformer. I use a bell transformer with the 10 volt secondary used as primary in series with two 7½-watt, 110-volt lamps, hooked up as shown.

The secondary voltage with both lamps in circuit is 40—just right for small condensers. If one of the lamps is turned out, secondary voltage drops to 10, correct for large filter condensers.

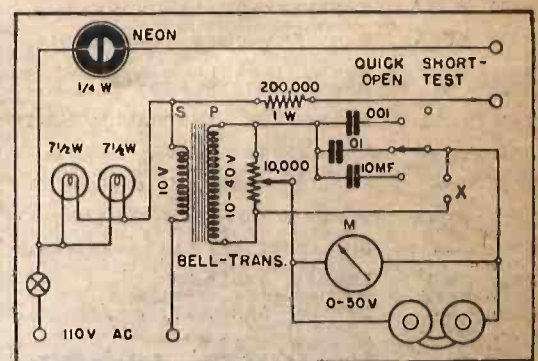

Different makes of bell transformers may vary the output voltage. The meter and neon lamp are not necessary, but the meter gives a visual check on the null point as heard in the phones.

W. F. WHALEN,
Ottawa, Canada

(A filament transformer should work in place of a bell transformer in this circuit.—Editor)

THE WORLD'S MOST FAMOUS BOOK FOR RADIO-ELECTRONIC BEGINNERS (No previous training necessary)

LEARN RADIO-ELECTRONICS EASIER BETTER FASTER for Only \$5.



A. A. GHIRARDI
Let Radio's most widely-read technical author help you start training NOW for a fascinating, profitable future!

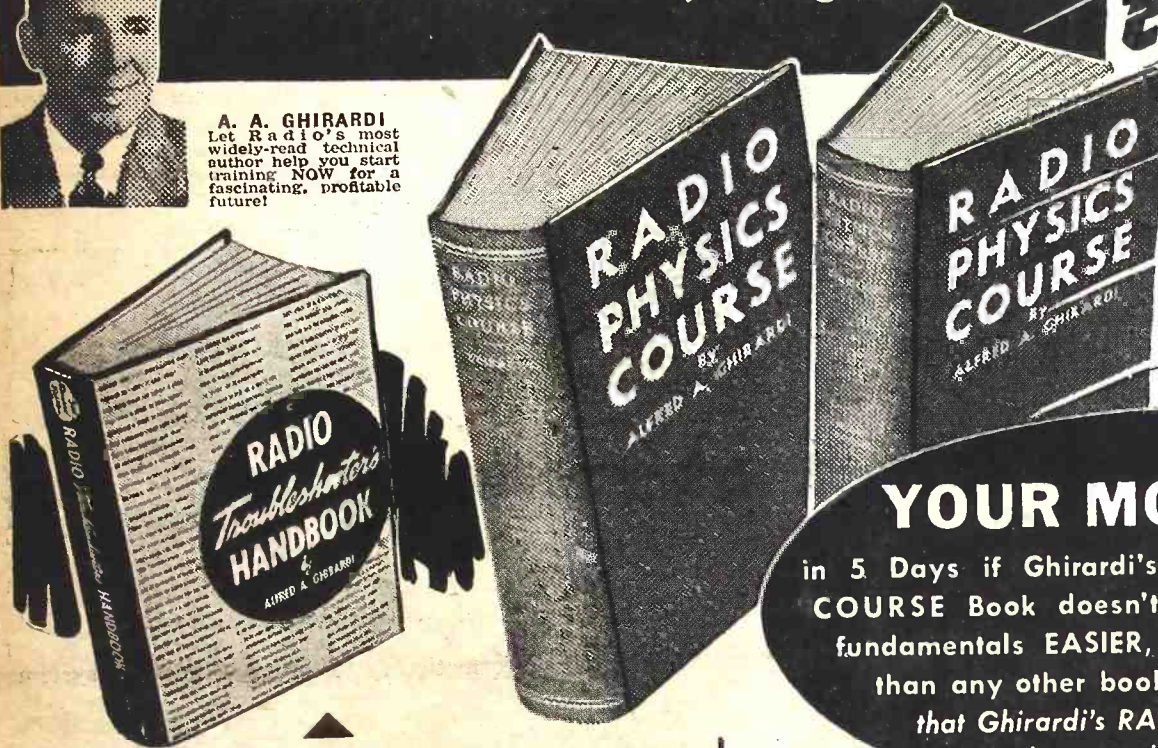

YOUR MONEY BACK
in 5 Days if Ghirardi's 972-page RADIO PHYSICS COURSE Book doesn't teach you Radio-Electronic fundamentals EASIER, FASTER and at LESS COST than any other book! That's how sure we are that Ghirardi's RADIO PHYSICS COURSE is the very best in the field!

HERE'S HOW TO REPAIR RADIOS THE EASY WAY!

A Definite Guide for Diagnosing, Locating and Repairing Radio Receiver Troubles

Radio servicemen everywhere say that this big 3rd edition of A. A. Ghirardi's **RADIO TROUBLESHOOTER'S HANDBOOK** is a complete guide to the trouble diagnosis, locating and fast repairing of **EVERY TYPE OF RADIO RECEIVER NOW IN USE**. It isn't a "study" book. You simply turn to it whenever you want to fix a particular type of trouble in a particular make of radio. Its 404-page Case History Section

gives full details on common trouble symptoms, their causes and remedies for **OVER 4,000 DIFFERENT RADIO RECEIVER MODELS**. It describes the trouble exactly—tells exactly how to repair it. It eliminates extensive testing—helps you do two jobs in the time normally required for one—repair cheap sets at a profit—substitute tubes and parts profitably—train new helpers, etc., etc.

In addition, hundreds of other pages are devoted to the most modern tube chart you've ever seen; tube and parts substitution data; I-F alignment peaks for over 20,000 superhets; a big section on I-F transformer troubles—and dozens of charts, graphs, helpful hints and data compilations—all carefully indexed for quick, easy reference.

This big, beautifully bound **HANDBOOK** is only \$5 (\$5.50 foreign)—on our **UNRESERVED 5-DAY MONEY-BACK GUARANTEE**. You cannot lose!

HERE'S HOW TO LEARN MODERN RADIO SERVICE WORK

... without an Instructor!

A. A. Ghirardi's **MODERN RADIO SERVICING** is the only single, inexpensive book that gives a complete, easily understandable course in modern radio repair work in all of its branches. Written so simply you can understand it without an instructor! Read from the beginning it takes you step by step through all phases of the work—or, used as a reference book by busy servicemen, it serves as a beautifully cross-indexed work for "brushing up" on any type of work that may puzzle you.

Included is a thorough explanation of all Test Instruments, telling exactly how they should be used and why (it even gives all necessary data for the construction of test equipment for those who prefer to make their own!); Receiver Troubleshooting Procedure and Circuit Analysis; Testing and Repair of Components; Installations; Adjustments; etc., etc.—also How to Start a Successful Service Business. 1300 pages; 720 Self-Testing Review Questions; 700 helpful illustrations and diagrams. Only \$5 complete (\$5.50 foreign) on our 5-Day Money-Back Guarantee.



SAVE MONEY!

See coupon for special combination offer on **MODERN RADIO SERVICING** and **TROUBLESHOOTER'S HANDBOOK**—over 2040 pages of helpful service data!

MOST POPULAR FOR ARMY-NAVY AND CIVILIAN RADIO TRAINING

This same inexpensive book has given more people their basic Radio-Electronic training than any other ever published. It is more widely endorsed by men who know. Because of its sheer merit, it is more universally used for home study, and more widely employed in U. S. Army Signal Corps, Navy and civilian schools and colleges than any other book on the subject. Would you want any better proof than this?

EVEN IF YOU DON'T KNOW ANYTHING ABOUT RADIO!

Even if you've had no previous Radio or Electrical training or experience, it's easy to learn from Ghirardi's **RADIO PHYSICS COURSE**! Everything that can be done to make learning easy has been done for you. It painstakingly explains everything in detail so you cannot fail to understand. Over 500 specially prepared illustrations help you to visualize every action. You don't have to know a single thing about Radio in advance. All you need is a little spare reading and a desire to get started **RIGHT** for a profitable future in any of Radio-Electronics' many branches—

from service work to aviation, military, broadcasting, manufacturing, public address and many others.

SCOPE OF 36 COURSES IN ONE

Actually, **RADIO PHYSICS COURSE** gives you the scope of 36 different courses in one convenient, inexpensive big book. Nothing is left out. Nothing is condensed. Nothing is left to chance. You learn all you need to know. You don't need to wait for monthly lessons. You progress as rapidly as you wish in your spare time and in the comfort of your own home.

A \$50 VALUE FOR \$5 COMPLETE

RADIO PHYSICS COURSE is acclaimed everywhere as the "biggest bargain" available in Radio-Electronic training. If it were broken into sections and sold as a course, you'd regard it as a bargain at \$50 or more—but you actually buy it all here complete in one big 972-page handsomely bound book for only \$5 (\$5.50 foreign) and with our absolute **5-DAY MONEY-BACK GUARANTEE**. Get the book and see for yourself. Compare it with any other book or course on the market—at any price. See how much more complete it is, how much better illustrated, how much easier to understand! You be the judge! You cannot lose!

WARNING! Paper shortages may make it impossible for us to continue meeting the tremendous demand for all Ghirardi Radio Books. Don't take chances! Order yours today while they're still available. Use this Order Form.

RADIO & TECHNICAL DIVISION OF MURRAY HILL BOOKS, INC.
Dept. RC-15, 232 Madison Ave., New York 16, N. Y.

Enclosed find \$..... for books checked; or send C.O.D. for this amt. plus postage. If I am not fully satisfied, I may return the books within 5 days and receive my money back.

- | | |
|--|---|
| <input type="checkbox"/> RADIO PHYSICS COURSE
\$5.00 (\$5.50 foreign) | <input type="checkbox"/> 3rd. Edit. RADIO TROUBLESHOOTER'S HANDBOOK
\$5.00 (\$5.50 foreign) |
| <input type="checkbox"/> Special "MONEY-SAVING"
Combination MODERN RADIO SERVICING with the HANDBOOK
\$9.50 (\$10.50 foreign) | <input type="checkbox"/> MODERN RADIO SERVICING
\$5.00 (\$5.50 foreign) |

Name
Address
City City Dist. No. State

REPAIR ANY KIND OF RADIO EQUIPMENT
PREPARE YOURSELF FOR A BETTER JOB AT HIGHER PAY IN THE RADIO-ELECTRONIC FIELD

THE QUESTION BOX

ADDING A RECORDER

? I would like to add a recorder to my Rauland Model 40 Power Amplifier. What value of magnetic cutting head will work best, and how should it be connected? Also please show how it should be connected.

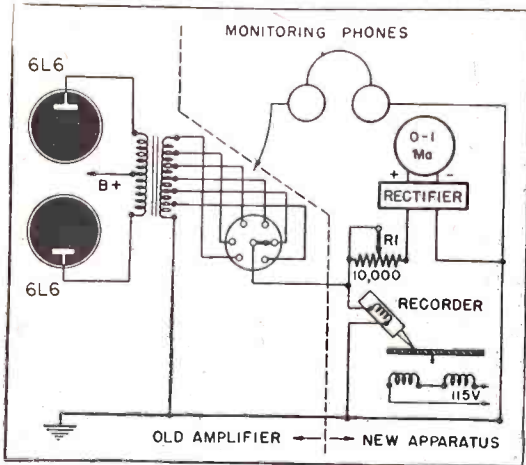

Please show also how a meter-type overload indicator should be connected to cutting head.—W. C. H., Cleveland, Ohio.

A. With your present output transformer you can use a magnetic cutting head of any value between 2.66 and 16 ohms impedance. If you have an 8-ohm cutter connect it to the 8-ohm tap of the output transformer as shown in the diagram. Under such conditions the speaker voice coil should be disconnected.

Many types of meter and tube indicators can be arranged, a simple system being shown in the diagram. After you have made a few experimental cuttings set the resistor R_1 so that the meter will remain near the center of the scale for an average recording. Should the meter read high at all settings of R_1 , put another resistor of 5,000 or 10,000 ohms in series with it, so that the needle may be brought to center-scale for a reference mark. The monitoring phones should be attached to the tap which gives the best results as judged by listening.

TWO-INPUT AMPLIFIER

? Please print a diagram of a high-fidelity amplifier using two 6L6's in the output. I require two inputs for crystal microphones

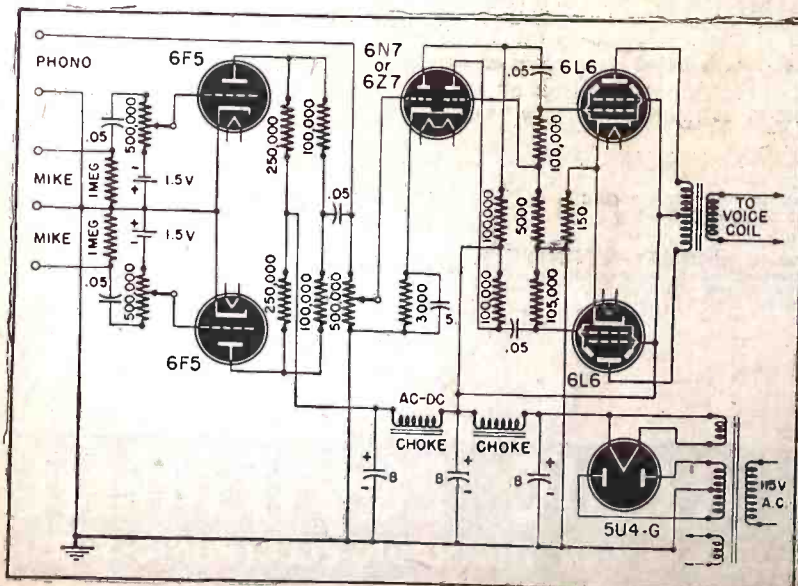

and one for phonograph.—G. R. C., Daytona Beach, Fla.

A. The circuit shown will give excellent fidelity, if carefully built from high-grade parts. The 1.5-volt bias cells shown may be ordinary flashlight cells. The large choke should be a low-resistance type with a carrying capacity of at least 150 Ma.; the other one may be a small A.C.-D.C. type as it carries very little current.

Various types of tubes may be used; the 6F5's may be replaced by 6C5's if they are more available; if the cathode resistor is changed, 6F6's may be used in the output instead of 6L6's. Large power transformer and choke and a high-quality output transformer will greatly improve the quality of reproduction.

A TUNED R.F. STAGE

? I would appreciate a circuit diagram and coil specifications for an efficient tuned radio frequency to be connected to the antenna post of a superheterodyne which at present has no R.F. stage ahead of the converter. The receiver has abundant R.F.

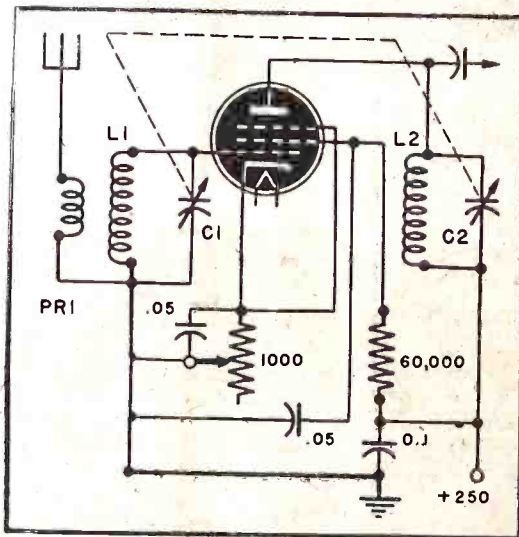

amplification and the purpose of the added stage is to eliminate or decrease materially image frequencies.

The preselector stage is to be used in connection with the short-wave band only. Tuning range of single coil 5.5 to 18 Mc. Filament and plate currents supplied by the receiver. Tuning condenser capacity 365 mmf. Type of 6.3-volt

tube is optional.—E. G., Cleveland, Ohio.

A. An efficient and selective amplifier is shown in the diagram. It may be considerably simplified by substituting a radio-frequency choke for the L_2 , C_2 combination. This will cut sensitivity somewhat, but will also cut out tracking troubles, as you will have only a single tuning condenser. A 6K7 or 6J7 tube may be used.

To cover the required range the coils may be wound with 9 turns of No. 18 wire on 1½-inch forms. Windings should be spaced to cover 1¼ inches. Primary may be 4 to 6 turns of No. 24 to 30 insulated wire wound near the ground end of L_1 .

SLOW-STARTING MOTOR

? I have a small G.E. record player attached to my radio. Before I can play any records I usually have to wait from 10 to 15 minutes for the turntable to gather sufficient speed. After the turntable comes up to speed reproduction is perfect.—T. J. H., Brooklyn, N. Y.

A. It would appear most likely that your motor is suffering from lack of lubrication or from stiff or heavy grease. Not having information as to the type of oiling system on your particular changer, my advice would be to clean out all present lubricant with kerosene, then to use either vaseline or a light grade of liquid oil, according to whether your player is intended to be used with solid or liquid lubricant. While it is possible there may be some other reason for the peculiar action of your motor, this is the most likely one.

4-TUBE TRF RECEIVER

? I have a 6U7, a 6P5, a 6F5 and a 12A7. Is it possible to use these in a TRF radio receiver?—D. W., Sparta, Wisc.

A. The above tubes are used in the diagram shown. Other tubes may be used, for example a 6K7 instead of the 6U7 or a 6C5 instead of the 6P5. A 6C5 may also replace the 6F5 with some loss of gain, and by changing the line cord resistor, a 25A7 or other rectifier-power-amplifier may be used.

If too much regeneration is experienced, a condenser from the junction of the screen-grid and plate coil of the first tube (point A) to cathode, and a radio-frequency choke between that point and the high-voltage source may be necessary.

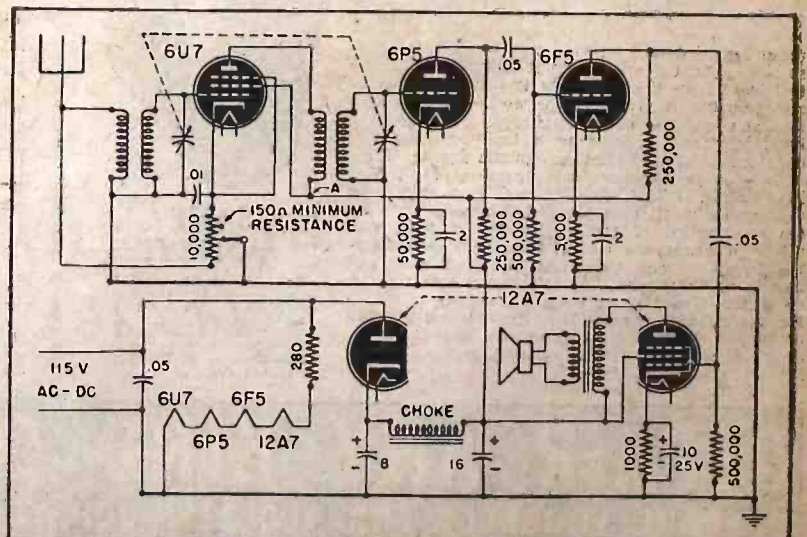

WHERE BUT MT. CARMEL

WOULD YOU EXPECT TO FIND
SKILLS LIKE THESE?

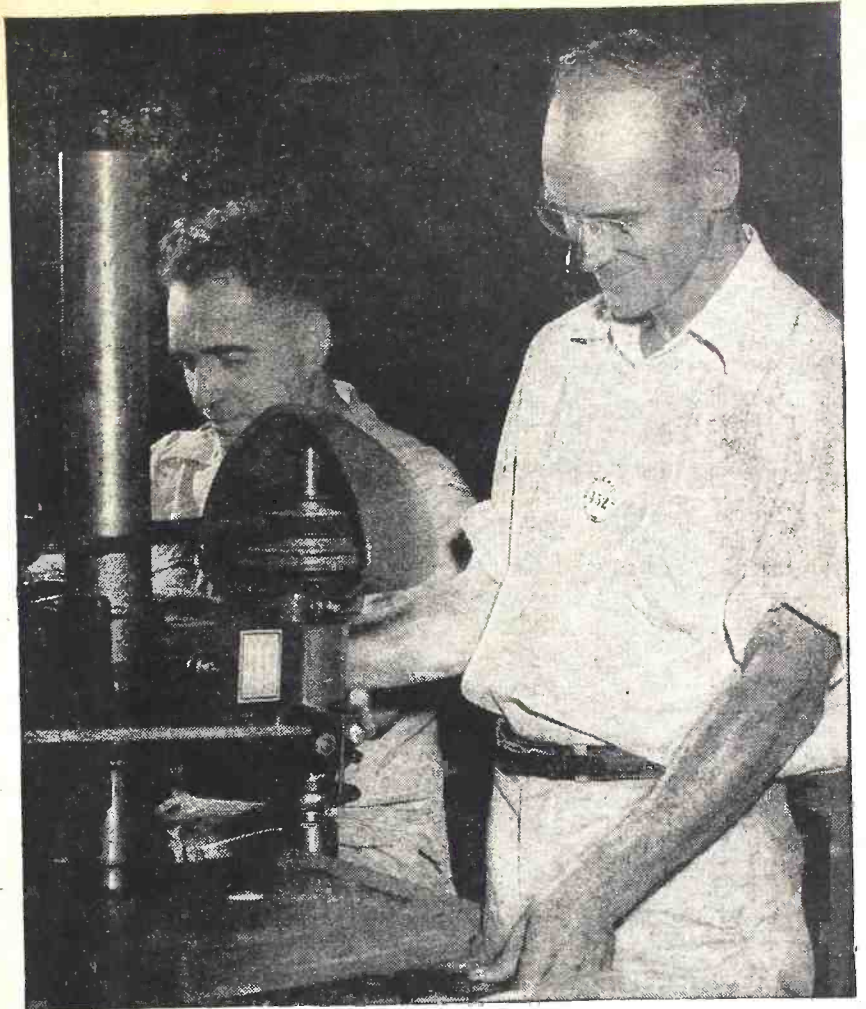

Concentration with a smile—One more reason for the precision performance of Meissner products. It's a smile of pride in a job well done that helps make personnel "precision-el."

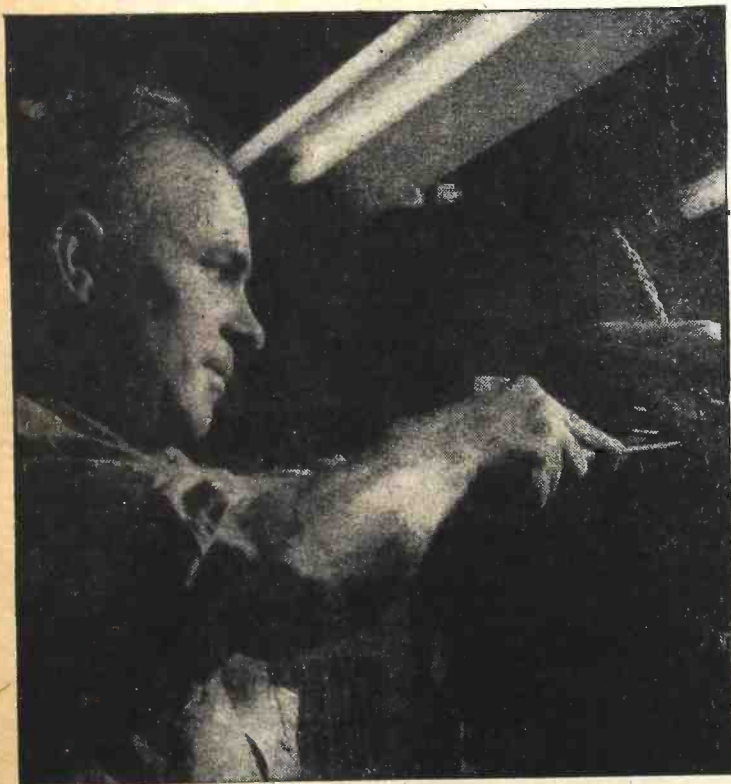

Sure, deft, hands—No compromise with quality here at Meissner as "precision-el" produces vital electronic war equipment.



Easy Way To "Step Up" Old Receivers!

Designed primarily as original parts in high-gain receivers, these Meissner Ferrocarril I. F. Input and Output Transformers get top results in stepping up performance of today's well-worn receivers. Their special powdered iron core permits higher "Q" with resultant increase in selectivity and gain. All units double-tuned, with ceramic base, mica dielectric trimmers, thoroughly impregnated Litz wire, and shield with black crackle finish. Frequency range, 360-600. List price, \$2.20 each.



MEISSNER

MANUFACTURING COMPANY • MT. CARMEL, ILL.

ADVANCED ELECTRONIC RESEARCH AND MANUFACTURE
Export Division: 25 Warren St., New York; Cable: Simontrice



Precisioneer—The years of experience this Meissner veteran brings to his job are just another reason why the Meissner products you use will do your job better.

TRY THIS ONE!

A PRACTICE BUZZER FOR CODE STUDY

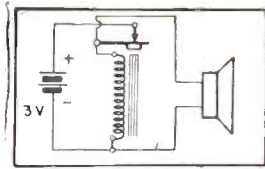

I find that a high-frequency buzzer with a small PM speaker connected across its coil makes an exceptionally good code practice set.

The buzzer should be of the adjustable type so the tone can be varied. It has more than enough volume—in fact, I intend to put a volume control on it.

AL DILLASHAW,
San Antonio, Texas

SIMPLE MERCURY SWITCH

The figure illustrates an easy-to-build mercury switch for use at 110 volt loads. Two common pins are pushed through a cork in a glass pill-bottle (obtainable from drug stores), leads being soldered to binding posts. I bent the ends of the pins into loops to make better contact.

A small amount of mercury is placed in the bottle and the bottle clamped to a wooden arm. Two stops limit the motion of the latter. A wooden upright and base holds the assembly.

HOWARD H. ARNOLD,
Marshalltown, Ia.

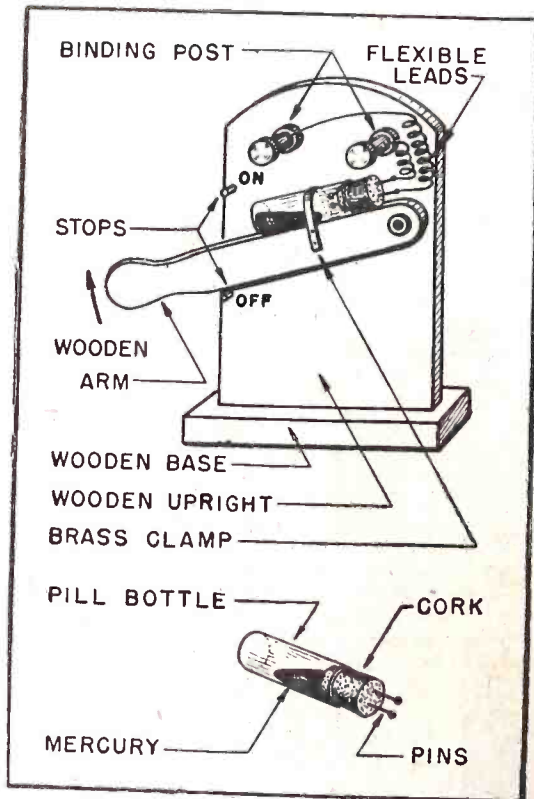

QUIETS NOISY TUBES

Before replacing tubes found to be noisy, touch the soldering iron to the cap and each prong. The noise in many tubes is due to a high resistance or loose contact at one of the tube prongs. Recheck by operation in receiver. If the tube is of the type that has a grid-cap, do not forget to touch it up with the iron as well.

GLENN SEATON,
Cleveland Hts, Ohio

MINIATURE TUBE MOUNTING

In working with the miniature tubes such as the 1S4, 1T4, etc., it is frequently necessary to mount the tube socket to the underside of the panel in an upside-down position. With the amphenol socket this means making a metal bracket, drilling and reaming out a $\frac{5}{8}$ " hole in it for the socket and

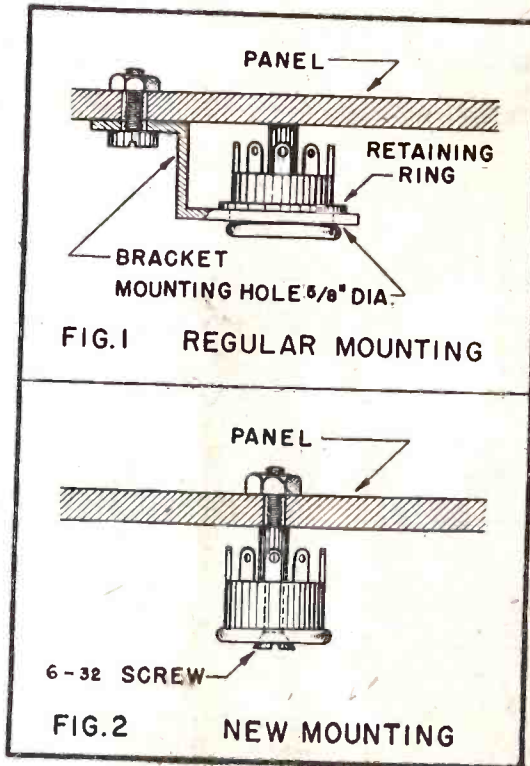

then fastening the socket in the bracket with the retainer ring. The bracket must then be drilled and bolted on to the panel (see Fig. 1). This requires considerable time, and when the job is completed the bracket is in the way so that soldering the wires to the base of the socket is difficult as space here is at a premium.

These sockets can easily be mounted (see Fig. 2) by drilling and tapping a single hole in the panel (6/32 thread). The socket is held in place by passing a 6/32 screw one inch long through the hole in the center of the socket and into the threaded hole in the panel. If the metal panel is too thin to thread, a nut can be used on top of the panel. A screw with a flat or countersunk head is preferable as the head will not protrude much above the top of the socket. The diameter of the screw head can be reduced slightly so as not to touch the tube pins by rotating the screw, in a hand drill, against a file. This makes a neat job, the socket can be easily removed, and since the bracket is eliminated, the wires to the socket can be more easily soldered.

R. S. HAVENHILL,
Josephstown, Penna.

LOW-NOTE SUPPRESSOR

Recently I built an intercommunication system using a pair of $3\frac{1}{2}$ -inch PM's, but found the speakers to have a frequency response too low for normal crisp voice reproduction. I applied a light coat of lacquer to the paper cone with a spray gun. This eliminated all trace of "woofers" action and brought the frequency response up to where it sounded very well on voice.

DAN W. DAMROW,
Chicago, Illinois

FRONT SEAT RADIO

The writer has his house wired as illustrated.

Two or three headsets plugged in on the line, causes a little drop in volume of the speaker, but that can be overcome by increasing the volume control on the radio.

Father can cut out the radio speaker, and listen to his favorite program while mother is quarreling with the children about getting their school home-work done.

Or little Johnny can have his silent reception while Pa and Ma are entertaining their callers.

Mother can plug in a speaker in the kitchen (instead of phones) and enjoy her work over a hot stove, or in the afternoon, she can plug in the phones in order not to wake up the baby.

An outlet should be put in the dining room for meals, the little bedroom off to the side for convalescents, and dad's den for poor, tired Father where he can escape the household and other worries.

Unbelievable as it may be to Radio Engineers, the writer has run as many as a hundred 2000-ohm headsets in one building from this kind of hookup, with speaker cut out, of course.

FRED H. RANDOLPH,
Booneville, Ark.

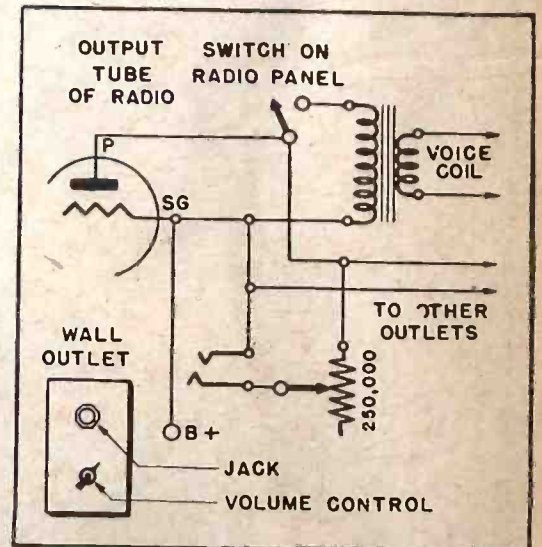

SIMPLEST OSCILLATOR

To build this code oscillator you need only two parts, a triode tube of any type and a center-tapped magnetic speaker. The power required is small, and may be obtained from a receiver, in which case the 'B plus lead may be connected to some screen grid lead in the receiver and B minus to the chassis.

A condenser may be added (dotted lines) to lower the tone obtained.

E. E. YOUNGKIN,
Altoona, Pa.

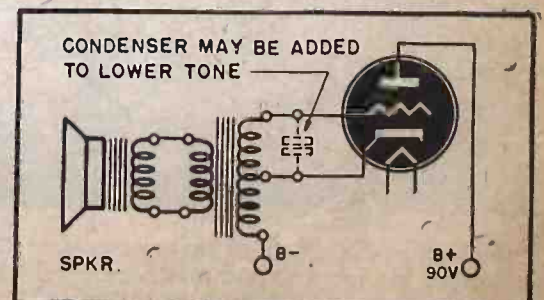

HOGARTH'S NOT WORRIED
 ABOUT POST WAR PLANS. HIS
ECHOPHONE EC-1
 TAKES CARE OF THAT!



ECHOPHONE MODEL EC-1

(Illustrated) a compact communications receiver with every necessary feature for good reception. Covers from 550 kc. to 30 mc. on 3 bands. Electrical bandspread on all bands. Six tubes. Self-contained speaker. 115-125 volts AC or DC.



ECHOPHONE RADIO CO., 540 NORTH MICHIGAN AVE., CHICAGO 11, ILLINOIS

Here's How CREI
Can Prepare
You Now for



... A Better Job
and a Post-War Career in
RADIO - ELECTRONICS

Add CREI technical training to your present experience—then get that better radio job you want—make more money—enjoy security.

After the war will come the period of the "survival of the fittest." Employers can then once again be "choosy" in selecting the best-trained, best-equipped men for the best jobs.

In our proved course of home-study training, you learn not only *how* . . . but *why*! Easy-to-read-and-understand lessons are provided you well in advance, and each student has his personal instructor who corrects, criticizes and offers suggestions on each lesson examination. This is the successful CREI training that has trained more than 8,000 professional radiomen since 1927. Your ability to solve tough problems on paper and then follow-up with the necessary mechanical operation, is a true indication that you have the confidence born of knowledge . . . confidence in your ability to get and hold an important job with a secure, promising post-war future. These jobs are waiting today for radiomen with up-to-date CREI technical training. Investigate CREI home-study training . . . and prepare now for security and happiness in the coming New World of Electronics!

WRITE FOR NEW, FREE 36-PAGE BOOKLET

If you have had professional or amateur radio experience and want to make more money—let us help you qualify for a better radio job. TELL US ABOUT YOURSELF, so we can intelligently plan a course best suited for your needs.—PLEASE STATE BRIEFLY YOUR BACKGROUND OF EXPERIENCE, EDUCATION AND PRESENT POSITION.



CAPITOL RADIO
ENGINEERING INSTITUTE

Home Study Courses in Practical Radio-Electronics Engineering for Professional Self-Improvement

Dept. RC-1, 3224 — 16th St., N. W.
WASHINGTON 10, D. C.

Contractors to U.S. Navy—U.S. Coast Guard—Canadian Broadcasting Corp.—Producers of Well-trained Technical Radiomen for Industry

Progress in Invention

Conducted by I. QUEEN

CONSTANT IMPEDANCE
REGULATOR

Patent No. 2,355,422

BROADCAST stations are often required to vary power input at specified times. These adjustments must not change impedance matching in any way. The figure shows a compensating circuit with a single control, the invention of Howard M. Crosby of Schenectady, N. Y. As series resistors are cut into the plate circuit for power reduction, the other end of the switch arm shunts the secondary of the modulation transformer MT with the proper impedance to maintain the correct relation between modulator and oscillator, and always reflect the same impedance back into the modulator primary.

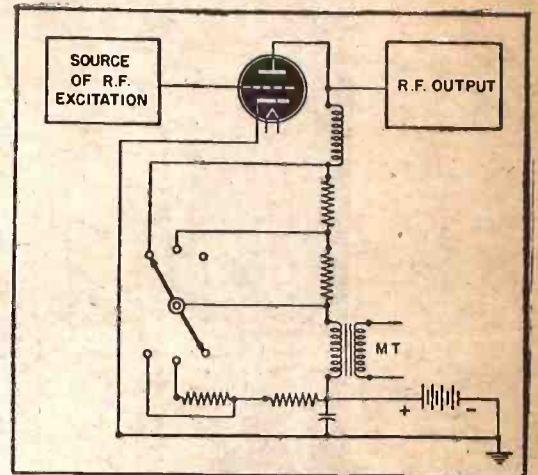

Patent No. 2,355,422

D.C. TO A.C. CONVERTER

Patent No. 2,352,299

WORN contacts and poor wave form result from vibrator sparking. These difficulties are eliminated by closing and opening contacts only while no current flows as is done in this circuit, patented by Alec H. B. Walker of London. When the bottom contact is made, C₂ discharges (through transformer primary), and the D.C. source charges C₁. The vibrator coil now being across the D.C., attracts the armature, whence C₁ discharges and C₂ charges. Contacts are therefore made only while condensers are fully charged or discharged. C₃ aids wave form.

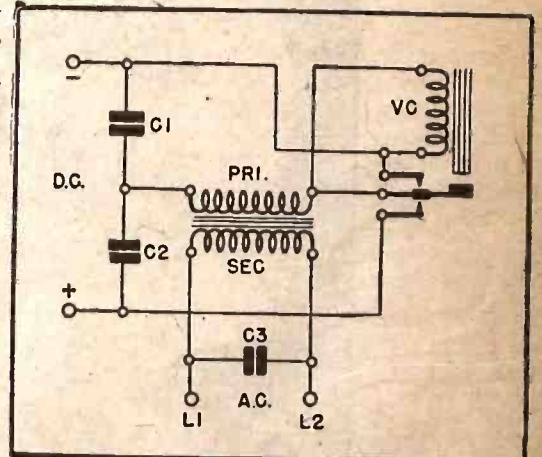

Patent No. 2,352,299

THYRATRON IGNITION
SYSTEM

Patent No. 2,353,527

THIS device eliminates pitted contacts, cam shaft wear and other disadvantages which attend the usual mechanical ignition system. Using a thyatron tube as shown only a very weak current need be made and broken.

The distributor and commutating device are synchronized. The latter has conducting and insulating segments contacted by a brush. When a conducting segment is contacted, the grid is grounded and no current flows. When contact is made with an insulating segment the grid is connected to the plus side of the battery, firing the tube, so that a heavy plate current flows through the transformer primary. The large condensers store a charge and aid in causing a heavy spark plug current.

This ignition system was patented by Enrique G. Touceda, Loudonville, and Donald A. Wilbur, Troy, N. Y.

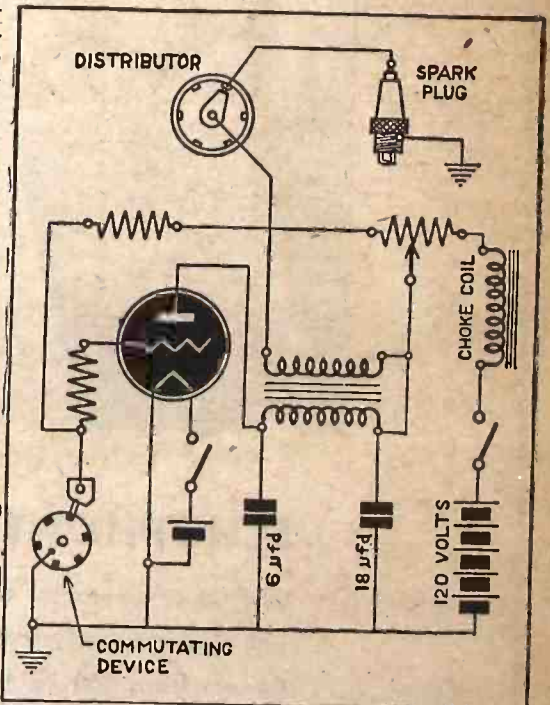

Above—Patent No. 2,353,527. Below—Patent No. 2,352,931.

A BASS AND TREBLE BOOSTER

Patent No. 2,352,931

A SIMPLE method is provided of boosting either bass or treble by means of one potentiometer adjustment, described in a patent obtained by Kirby B. Austin, Bridgeport, Conn. When this control in the 6J5 grid circuit (see Fig. 1) is at the upper point, curve C results (Fig. 2). Here the .01 condenser, the cathode resistor and coil C shunt the potentiometer. When the slider is at the lower end, curve A results. Now bass is boosted because the condenser shunts cathode resistor and feed-back coil C. Compare these two extreme curves with curve B when the .01 capacitor is disconnected. The sharp peak at 200 cycles is due to mechanical characteristics of the particular speaker used.

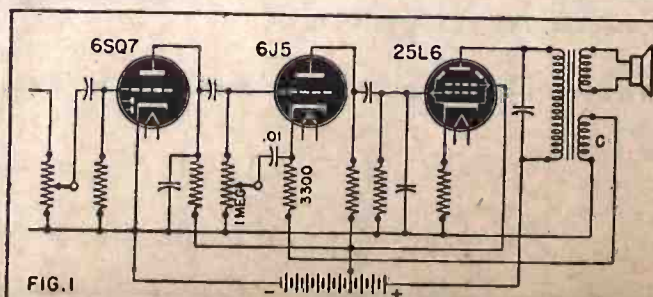

FIG. 1

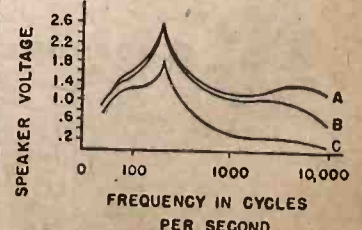

FIG. 2

THE DOUGH YOU BLOW
-will bring U.S. woe!



1918
What a boom we were handed by World War No. 1! Money came easily—went easily. Everybody was splurging on everything—from silk underwear to diamond sunbursts. Prices went skying. Sugar eventually hit 28¢ a pound!



1921
Bye-bye, boom. Factories closed; men laid off. Prices and wages sinking fast. Wish we'd banked some of that dough we'd blown a few years back! With jobs scarce, that money would have come in mighty handy, then.



1929
Prosperity. Stocks up fifty points in a week. Again everybody was buying everything—yachts, jewelry, stocks, real estate, regardless of cost. Depression? Phooey... we thought we'd found a way to lick depression.



1932
Or had we? Bread lines, apple vendors. WPA. "Brother, can you spare a dime?" No jobs. Prices dropping. Wages dropping. Everything dropping—except the mortgage on the house. "What goes up must come down."



1944
We're splurging again. Americans have been earning more money. But even today there are fewer goods to spend it on—so naturally prices rise. We must keep them in check. **DON'T LET IT ALL HAPPEN AGAIN!**

4 THINGS TO DO to keep prices down and help avoid another depression

1. Buy only what you really need.
2. When you buy, pay no more than the ceiling prices. Pay your ration points in full.
3. Keep your *own* prices down. Don't take advantage of war conditions to ask for more—for your labor, your services, or the goods you sell.
4. *Save.* Buy and hold all the War Bonds you can afford—to help pay for the war and insure your future. Keep up your insurance.

**EVERY
 WAR BOND
 YOU BUY
 WILL HELP
 US
 KEEP
 PRICES DOWN**

FOR **SPEEDY**
ACCURATE
ALIGNMENT

**Test
Oscillator**



SUPREME MODEL 571

- Simple Operation — all ranges read on two basic scales.
- Dual Tuning Ratio. One for speed—one for vernier adjustments.
- Electron coupled circuit giving greatest stability, Iron core coils.
- Ladder Attenuator.
- Double shielding minimizes leakage.
- Golden Oak carrying case.

SPECIFICATIONS

R.F. RANGES:

65-205 KC; 205-650KC;
650-2050 KC; 2050-6500 KC;
6.5-20.5 MC. Harmonics to
82 Megacycles.

AUDIO FREQUENCY:

400 cycles available for external testing.

INTERNAL MODULATION:

R.F. Carrier modulated at approximately 30% and 70% at 400 cycles. Modulation level selected by toggle switch.

EXTERNAL MODULATION:

Jack provided for external audio modulation.

ACCURACY:

1/2 of 1% on first three bands. 1% on last two bands.

SIZE:

9-1/2"x8-11/16"x7-3/8"

POWER SUPPLY:

115 volts 60 cycles—Special voltage and frequency on request.

SUPREME

SUPREME INSTRUMENTS CORP.
Greenwood, Miss., U. S. A.

ELECTRONIC GUN LOCATOR

(Continued from page 207)

ling through the air at a known regular speed and in a regular direction. Unfortunately, the speed and path of sound waves in air are dependent upon wind and other atmospheric conditions. Accordingly, each Field Artillery Observation Battalion includes a meteorological section which obtains the necessary meteorological data to correct for deviations which may result from atmospheric conditions. Special meteorological techniques have been evolved which have found wide application in other fields as well as sound ranging.

The microphone array in sound ranging, as described above, may be spread over a distance of 10 to 15 thousand yards. About 10 miles of wire are required to connect all these microphones to the recording station. Since the sound ranging installation is within the combat area, this wire network is often cut by combat vehicles and troops moving across the wires, and by friendly or enemy shellfire. The time necessary for setting up the sound ranging apparatus is primarily dependent upon the length of time required to lay the wire. In general, a flat terrain provides the most suitable area for the laying of wire. However, in zones similar to the Italian combat areas, sound ranging installations may be required in topography which may not provide more than a mile or two of level ground separated by gullies or mountains.

The apparent solution to this problem in sound ranging appears to be the utilization, in place of the wire lines, of a re-

lay system consisting of a radio set at each microphone position to transmit sound waves picked up by the microphone to a receiver at the recording station, for input into the oscillograph equipment.

However, the actual sound or pressure wave picked up by the sound ranging microphone is of such low frequency (pitch), 5 to 25 cycles per second, that it is usually below the range of audibility. The superimposed harmonics or overtones of much higher frequency are the gun sounds which are heard. Accordingly, no standard radio set can be used for this purpose, since the standard Signal Corps radio sets will not handle frequencies as low as 25 cycles per second.

With our entry into Italy, the need for a radio relay system for sound ranging became increasingly pressing. Therefore, as a unique stop-gap solution, a special modulator assembly was developed, which, in essence, changes the frequency of the sound picked up by the microphone to an audible frequency. This audible sound can be transmitted by any standard radio set from the microphone position to a similar radio set at the recording station. At the latter point, a demodulator unit is provided which changes the audio tone back to a sound ranging signal identical to that picked up by the sound ranging microphone. This original signal is then recorded, presenting the same record as would normally be supplied by using extensive wire lines.

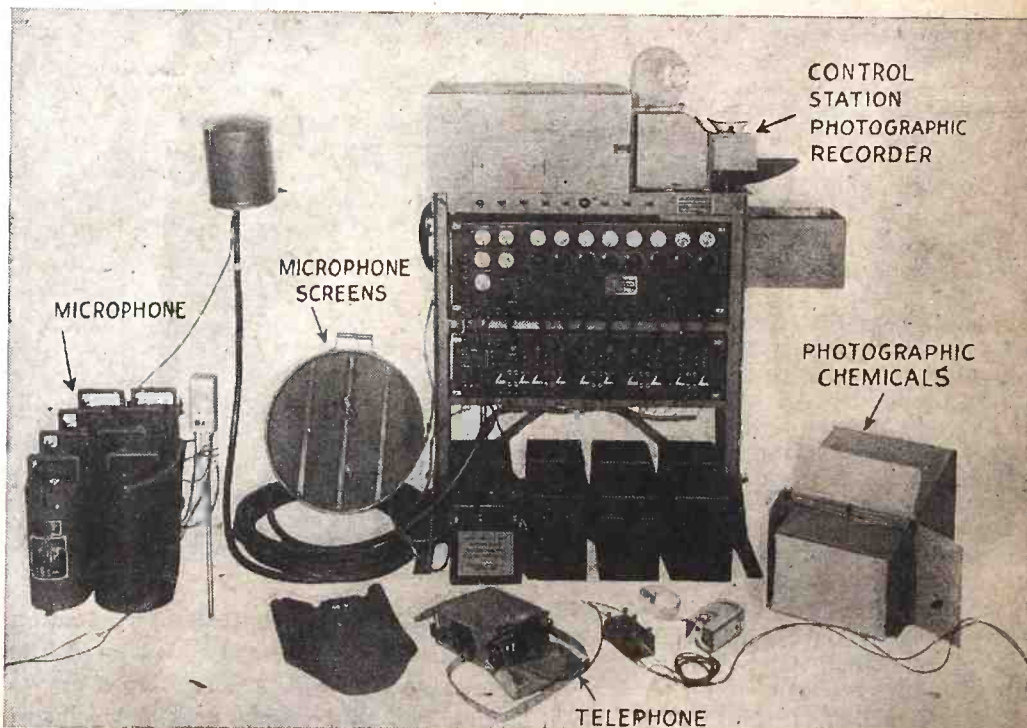

Signal Corps Photo

The apparatus used for locating enemy guns by sound pickup and electronic computation.

WHAT IS A VARIABLE-MU TUBE?

IS the 6K7—and others of its type—a variable-mu or a variable- μ tube? There is a difference, points out the Editor of *Wireless World* (London) in an editorial.

The Editor makes out a good case for his argument that "variable- μ " is incorrect, pointing out that the outstanding feature of a "variable-mu" tube is a variation in the mutual conductance as grid bias is increased negatively. (The 6K7 has a mutual conductance of 1450 micromhos at -3 volts and only 2 micromhos at -42.5 volts grid bias.) The amplification factor (μ) is affected only indirectly.

"Mu" might be an abbreviation for "mu-

tual conductance," but " μ " can mean only "amplification factor." Thus it is held that only the former term may be correctly used.

A rather impractical solution of the difficulty was proposed by *Wireless World's* editorial writer. In the United States a practical solution has already been approached in the near-obsolence of both the terms likely to cause confusion. We are more likely to hear of the "transconductance" of a tube than its "mutual conductance" today, and the term "variable-mu" is seldom heard today, having been almost entirely replaced by "super-control."

BROADCAST EQUIPMENT

(Continued from page 211)

erence frequency have been made, a written record is made of the oscillator output, the indication of the line-amplifier volume indicator, and the indication of the secondary scale of the modulation-monitor meter, which is calibrated in decibels. This procedure is then repeated, as shown in the data sheet of Fig. 2, for the frequencies given, and in that order. The oscillator is readjusted to the reference frequency at the conclusion of the test, in order to verify the original readings and determine that no unexpected changes have occurred during the operation. Finally, the reading of the modulation monitor at the 1,000-c.p.s. frequency is taken as the reference level and the results obtained are plotted on semi-logarithmic graph paper, as shown in Fig. 3.

Another method, practically the converse of that just described, does not appear to have any particular advantage, although it may be more convenient in some instances. The same precautions against regeneration are taken, and a reference frequency and modulation percentage are chosen as before. However, instead of keeping the oscillator output constant, it is varied so that the modulation-monitor meter indication is maintained at 50% throughout the range of frequencies specified in Fig. 2. The readings of the audio-oscillator volume indicator are then recorded and used for plotting the frequency characteristic curve. Thus, if at some frequency other than the 1,000-c.p.s. reference frequency, this volume indicator reads 1 decibel above the reference level, the overall response of the system is revealed as being down .1 db at that point.

It is quite obvious that equalization and frequency runs cannot be made during a station's regular program schedule. Any program modulation would nullify the results of the testing, and tone modulation would seriously interfere with the program. However, these necessary operations are provided for in the F.C.C. Rules and Regulations, which state: "The term 'experimental period' means that time between 12 midnight and local sunrise. This period may be used for experimental purposes in testing and maintaining apparatus by the licensee of any standard broadcast station on its assigned frequency and with its authorized power, provided no interference is caused to other stations maintaining a regular operating schedule within such period."

There are always at least two separate telephone lines between the main studios and the transmitter. This is most often the case with remotes as well. One line is the regular program wire, and may have an alternate for emergencies. The other is the intercommunication line or order wire. All of these lines are usually properly equalized, so that any one of them may be patched into the program circuit if necessary. If the lines are long, it is necessary to insert amplifiers known as "boosters" or "telephone repeaters" at intervals. The actual distance between repeaters depends upon individual circumstances, and is usually between 10 and 20 miles. All telephone lines and associated repeaters are furnished and maintained as a part of the service of the local Telephone Company. It should be understood that these are privately leased wires and do not go through a switchboard operator. They are considered as a part of the permanent installation and are not subject to tampering or interference. Although the telephone re-

RIDER VOLUME XIV COVERS 1941-42 RECEIVERS

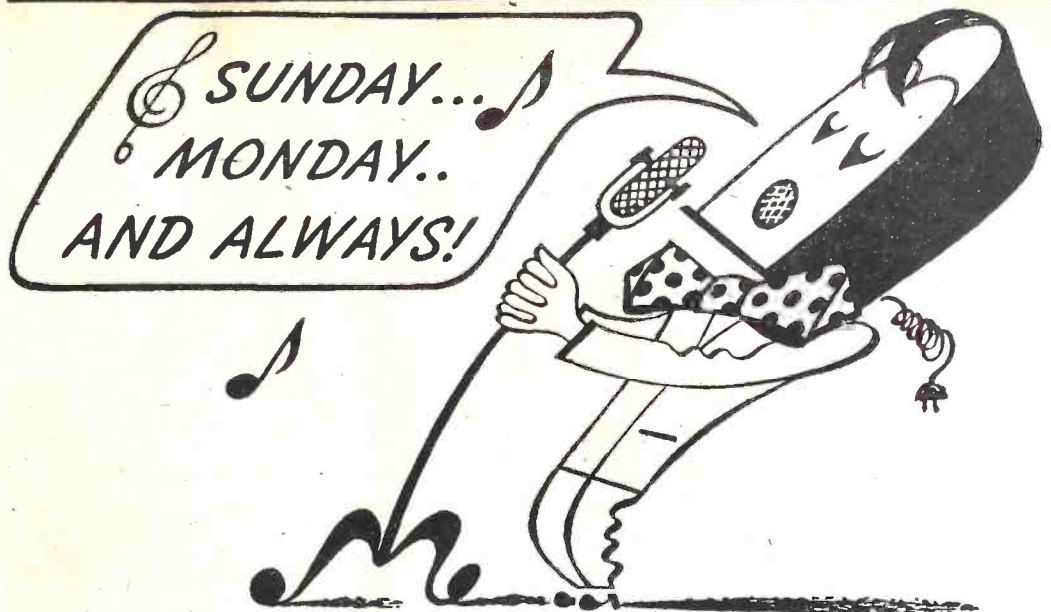

That's me three years ago. The first program I carried was Frank Sinatra — back in the days when a bobby sock was something worn by a London policeman.

My, how we 1941 models have worked since then. For most of us it's been too much and many of my contemporaries are now piled up in overcrowded service shops.

There is one bright spot however. Rider Manual Volume XIV is now off press. Carrying complete authorized servicing information on 1941-42 sets, we ailing sets are sure of correct diagnosis and quick painless repair.

But please be patient if your jobber's supply of Volume XIV is inadequate. He, and the Rider folks will get you your volume as fast as present WPB limitations permit.

RIDER MANUALS (14 VOLUMES)
Volumes XIV to VII . . . \$11.00 each volume
Volumes VI to III . . . 8.25 each volume
Abridged Manuals I to V
[1 volume] \$12.50
Automatic Record Changers
and Recorders 6.00
OTHER RIDER BOOKS YOU NEED
The Cathode Ray Tube at Work
 Accepted authority on subject \$3.00
Frequency Modulation
 Gives principles of FM radio 1.50
Servicing by Signal Tracing
 Basic Method of radio servicing 3.00

The Meter at Work
 An elementary text on meters 1.50
The Oscillator at Work
 How to use, test and repair 2.00
Vacuum Tube Voltmeters
 Both theory and practice 2.00
Automatic Frequency Control Systems
 —also automatic tuning systems 1.25
A-C Calculation Charts
 Two to five times as fast as slide rule . . . 7.50
Hour-A-Day-with-Rider Series—
 On "Alternating Currents in Radio Receivers"—
 On "Resonance & Alignment"—
 On "Automatic Volume Control"—
 On "D-C Voltage Distribution" 90c each

JOHN F. RIDER PUBLISHER, INC. 404 Fourth Avenue, New York 16, N. Y.
 Export Division: Rocke-International Electric Corp. 13 E. 40th Street New York City Cable: ARLAB

RIDER MANUALS *are complete* IN 14 VOLUMES

Fig. 3—Frequency characteristics of equalized line, as plotted from regular test run.

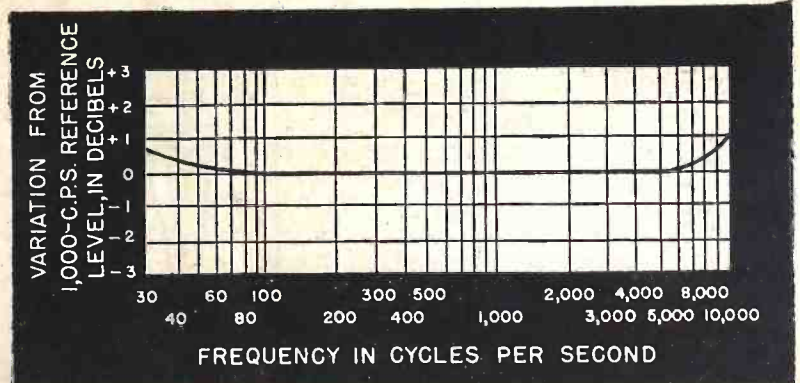

peaters undergo a rigid schedule of inspection and servicing, they may occasionally be a source of distortion. If this is detected when making the daily frequency run, it should be immediately reported to the

telephone company, so that the trouble may be remedied before air time.

The next installment will begin a discussion of the special requirements and operation of the line amplifier at the transmitting station.

LARGEST STOCKS CENTRALIZED SERVICE

FREE
Complete
Up-to-date
BUYING
GUIDE

Everything
in **RADIO and ELECTRONICS**



REPAIR and REPLACEMENT PARTS AVAILABLE without priority

SAVE TIME, CALL ALLIED FIRST!

Thousands use Allied's nation-wide service. Centralized

here are today's largest and most complete stocks under one roof. Over 10,000 items from all leading manufacturers . . . for the Armed Forces, Radio Training, Laboratories, Industry and Service Replacements. Our experienced staff simplifies procurement—expedites delivery. Call ALLIED first . . . for everything!

Write, Wire, or Phone Haymarket 6800

6 Radio Books for 75c

Dictionary of Radio Terms. No. 37-751 **10c** Radio Data Handbook. No. 37-754 **25c**

Radio Circuit Handbook. No. 37-753 **10c** Radio Builders Handbook. No. 37-750 **10c**

Radio Formulas & Data Book. No. 37-752 **10c** Simplified Radio Servicing. No. 37-755 **10c**

All Six Books No. 37-799 . . . **75c**

Write for Quantity Prices



ALLIED RADIO CORP., Dept. 2-A-5
833 W. Jackson Blvd., Chicago, Ill.

Please send following books (.....c enclosed)

- FREE 37-750 37-752 37-754
Buying 37-751 37-753 37-755
Guide No. 37-799 (All Six Books)

Name.....

Address.....

City..... State.....

ALLIED RADIO

A MAGNETIC RECORDER (Continued from page 220)

when recording, the switches being opened when playing back. The setting of the controls when recording is found by experiment. If there appears to be too much bass tone in playing back it will be necessary to set the controls for less resistance in the circuit when recording.

The output of the amplifier is fed through a 0.25 mfd. condenser, C14, and a selector switch which connects to a pick-up coil on the oscillator when recording. When playing back the selector switch grounds the oscillator pick-up coil and connects the output to the voice coil of the speaker. For recording the magnetic pick-up is connected across the oscillator pick-up coil to ground. The magnetic recorder head is connected by a selector switch from the input to the output of the amplifier, depending on whether you are recording or reproducing. The complete circuit appears in Fig. 1.

The oscillator circuit is a conventional Hartley. The oscillator coil is wound on a form 3 inches in diameter and 3 3/4 inches long. The primary has 260 turns of No. 33 S.S.E. closely wound. I tapped the coil at 45 turns and then at every fifth turn up to 80 turns. The plate supply is fed into one of these taps. I found that my oscillator worked best connected to the third tap. At the terminations of the windings I used some 2-56 screws as terminals. I applied a good liberal coating of coil dope. After this dried I wound the second coil L2, or No. 1 secondary. This is the coil used in the audio circuit in recording. This coil consists of 27 turns which are also brought to two 2-56 screws as terminals. After doping this winding and allowing it to dry I wound the second secondary, L3, which has 120 turns terminated in the same manner as the previous windings. This second secondary is the pick up coil for the erase coil. Both secondaries are wound with old No. 32 enamel wire taken from an old speaker field coil. The oscillator is tuned with an .01 mica condenser and should produce a signal between 27 and 30 Kc. The action of this supersonic frequency added to the signal

current is not well understood, but it is essential to good recording. It seems that it "loosens up" the wire magnetically, thus permitting the signal to be impressed on it.

As previously stated, when recording the output of the amplifier is fed through the No. 1 secondary of the oscillator to the recording head and then to the ground. The selector switch opens the oscillator cathode connection to ground when the machine is used to play back or reproduce.

The next step is the construction and selection of parts for the recording head. Here each individual must use his imagination and ingenuity. I have constructed about 12 heads. Each one used a different coil in either physical size, shape, number of turns, or D.C. resistance. Therefore I will describe the construction of only one, the one that has worked best.

All the heads worked but differed mainly in recording. The coil I used came from an old Atwater Kent magnetic speaker, the D.C. resistance measuring 700 ohms. The physical dimensions were 3/4 by 25/32 by 1/2 inches. The core was 3/16 by 5/16. Refer to Fig. 2 for the shape and manner of assembling. I have found that almost any coil will work as long as the gap in the core is kept between .001 to .003 inches. I used a piece of brass shim stock to maintain the gap at .002. I used a jeweler's hack saw with the finest blade obtainable to cut the slot for the wire to run through. After filing the core to shape, I assembled the pieces without putting them on the coil. I had them clamped together to enable me to drill the holes for 2-56 screws. Then I put the pieces on a wire, being careful to observe the order in which they were assembled so they may be reassembled in the exact way they were when the holes were drilled. With the wire strung out so the individual laminations were well separated I then heated them red hot with a blow torch and then left them to cool gradually.

I have also tried cooling them in an A.C. magnetic field—using an old speaker field for the purpose—and I believe this improved



Suggested by: Tom Blakey, Miami, Fla.

Frank BEAVEN

"He just can't settle down to reading until he's gone over it thoroughly with his pin detector."

the efficiency of the core. After cooling, I assembled the laminations on the coil. Hold this together with 2-56 brass screws and nuts. Before tightening dip the whole thing in dipping varnish, tighten and allow to dry.

Next get a small piece of phenolic tubing $\frac{1}{8}$ -inch diameter or some similar material, to wind the erase coil L4 on. The wire will be passed through this coil to clean it magnetically so it will be ready for another recording. I used No. 28 enamel wire although I do not believe the size or number of turns to be critical. The tubing was about $1\frac{1}{2}$ inches long and the coil on the tube about one inch long, layer wound about 200 turns. I mounted this between two pieces of $\frac{1}{4}$ -inch bakelite with holes drilled for a close fit so the tubing fits into the holes in the bakelite ends. Cement the coil in place with ordinary coil cement.

We are now ready to assemble the wire puller, head, and erase coil (See Fig. No. 3). I mounted the motor below the panel with an extension on the drive shaft. The drums I used were about 5 inches in diameter with a rim on each side to keep the wire from running off. I used microphone cable to connect the recording head and erase coil to the amplifier-oscillator assembly. A word of caution here in regard to running the wire puller; use your hand as a brake when stopping the reels! The wire may become hopelessly snarled if the reels are allowed to coast after the power is turned off. I rewind the wire by hand. Incidentally, when recording or reproducing the wire should move through the head at a constant speed of about 180 feet per minute. Whatever your speed is (it will work at slower speeds but not so well) it must be constant all the time.

You will have to find by trial and error how high to run the volume control and the audio filters when recording. Each set will vary, of course. If the reproduction sounds too bass and garbled it indicates you haven't filtered out the low frequencies enough. By connecting a pair of earphones across a small coil similar to the one used in the recording head and held close to the recording head you can monitor the record continuously.

Before you have taken the "bugs" out you will have broken your recording wire many times, unless you're exceptionally fortunate—and I've never yet met a radio ham that lucky. So remember this suggestion: when the wire breaks anneal the ends with a match flame, the heat from a cigaret, or bring out a tap from a filament supply and hold the wire across this voltage until it changes color. Then tie the ends together with a square knot and cut the surplus ends off. Apply a little more heat after tying the wire. The very small steel wire will burn if a match is held too close to wire, so be reasonably careful.

I installed a neon bulb as a volume level indicator as shown on the schematic. The point at which this bulb will flash can be controlled by R-20. R-20 should be adjusted so the bulb flashes just on the amplitude peaks.

And now that you know how to build it just dig into that "junk box" of radio parts over in the corner and you will find the makings of the magnetic wire recorder.

Parts List

- R1—2 meg.
- R2—800 ohms
- R3—2 meg.
- R4—500m ohms
- R5—500m ohms v.c.
- R6—2m ohms
- R7—1 meg.
- R8—250m ohms
- R9, 10, 11, 12—4m ohms—2 W
- R13—250m ohms
- R14—850m ohms—2 W
- R15—50m ohms—2 W
- R16—50m ohms



OUR CENTRAL LOCATION GIVES YOU QUICKER SERVICE!

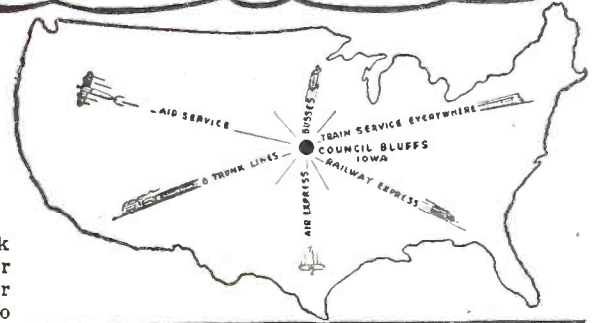

We want to take this occasion to thank you as one of thousands of customers for your business during the past year and for your friendship and loyalty which means so much to us.

In these days of scarcity we have done everything possible to bring you the best in radio parts and equipment. In spite of existing shortages we have made available thousands of items as shown in our printed circulars. As additional equipment is released, we will be the first to have it.

Our New Year's resolution is to continue to give you the same quick service on "hard-to-get" parts as thousands have enjoyed during the past year. Because parts move so rapidly these days we intend to continue our policy of publishing an up-to-date list of merchandise every two or three months. If you do not have our latest flyer—write today.

Sincerely,
Leo I. Meyerson
W9GFQ

HALLICRAFTERS

For many years we have been one of the country's largest distributors of Hallicrafter equipment. We have Hallicrafters available for immediate delivery on priority. For full particulars, write.

Mail Coupon Today

Wholesale Radio Laboratories RC-1
744 West Broadway
Council Bluffs, Iowa

- Send your reference Book "Tubes and Circuits". Here's my 10c.
- You bet I want a Tube-Base calculator. 25c is enclosed.
- Ship me your free radio map. 15c is enclosed for packing and mailing.
- Send your free flyer of hard-to-get radio parts.

Name.....

Address.....

Town..... State.....

I am an amateur; experimenter;
 service man.

OUR LATEST GET-ACQUAINTED OFFERS



TUBE AND CIRCUIT REFERENCE BOOK

Here's a handy reference book that meets the demand for simple, easy to understand data on substitution of radio tubes. Contains valuable technical information on tubes and circuits. It's a guide you'll refer to time and again. Send for your copy today! Only 10c post-paid.

TUBE-BASE CALCULATOR ONLY 25c

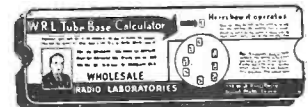

Here's just the calculator you've been looking for! Tells you quickly, tube characteristics that enable you to substitute available tubes for those hard to get. Only 25c. We pay shipping expense.

FREE Giant Radio Reference Map



Time zones, amateur zones, short wave stations. Other valuable information. Printed in colors; size $3\frac{1}{2} \times 4\frac{1}{2}$ ft. Yours free! Send 15c to help with packing and mailing.

WE'VE GOT THOSE HARD-TO-GET RADIO PARTS

You'll be surprised at the many hard-to-get parts we've been able to get for you fellows. Mikes, multi-t's, meters and many other items. They're yours as long as they last. Send for latest flyer. It's full of merchandise you've been trying to get! Stocks won't last long, so write today.



WHOLESALE RADIO LABORATORIES

744 W. BWDY. COUNCIL BLUFFS, IOWA

- R17—200 ohms 10 W
- R18—30m ohms
- R19—30m ohms
- R20—100m ohms v.c.
- R21—20m ohms—10 W
- R22—25m ohms
- R23—500m ohms
- All resistors $\frac{1}{2}$ W unless otherwise stated.
- C1—20 mfd.—50v
- C2—.06 mfd. 600v
- C3, 5, 12, 21—.06 600v
- C4, 11, 13—20 mfd. 50v
- C7, 10—.25 mfd. 600v
- C8, 9—.006 600v
- C14—.25 mfd. 600v
- C15, 16—8 mfd. 450v
- C17, 18—30 mfd. 450v
- C19—.0005 mfd. mica
- C20, 22—.01 mfd. mica
- C23—.03 mfd. 600v
- CH1, 2—125 m.h.
- CH3—Filter choke
- L1—Oscillator coil
- L2—No. 1 secondary
- L3—No. 2 secondary
- L4—Erase coil
- L5—Recording and reproducing head
- L, R—6-pole double-throw switch



BURSTEIN-APPLEBEE CO.

1012-1014 McGee St. • Kansas City 6, Missouri

BUY AN EXTRA WAR BOND

tween the two tubes. The amplifier is transformer-coupled in and out. Equalization is inserted in this amplifier to make it peak in the voice range, and frequency response being from about 80 to 6000 cycles.

In the middle of the Board can be seen a volume level meter. This meter is used across the output of each program amplifier to indicate the correct operating level. Below the decibel meter is a row of push-buttons. Each pushbutton is associated with a program amplifier output.

At no time during the playing of a record does the volume rise to more than minus

2-Db. on the peaks. The program amplifier output is set by using a record which has an abundance of high and low frequency passages. I suppose it will be asked, "Why not set the maximum program level by means of a standard audio frequency record." This has been found by actual practice to be useless for a good many reasons, the main one being that all crystal pick-up cartridges do not have the same voltage output for a given frequency, and also as they become weak through constant use this is a good check on their frequency response.

Hanging down from the front of the Board is seen the operator's breast-set. This consists of a pair of low impedance headphones, connected in parallel, and a dynamic microphone. Crystal microphones are little used in this type of work as they are not rugged enough for the abuse they get. Also the circuits are of low impedance to cut down noise and hum, and use of a high-impedance microphone would necessitate the use of an input transformer with its hum problems. The microphone can be raised or lowered to compensate somewhat for the different speaking voices of the operators.

Looking at the back of the Board as shown in the photograph, Fig. 2, is the following apparatus. At "A" in the upper left hand corner is the back of the permanent magnet speaker. In the upper right hand corner and labelled "B" are the two dial stepping relays.

In the middle is seen the back of the turntable motor. On the first shelf and to the left labelled "E" is the program monitor amplifier chassis. The phonograph pickup amplifier consists of a dual 100,000-ohm potentiometer working into the grids of a 6N7 tube. The crystal pickup is not grounded on one side as is the usual practice. The 6N7 tube is transformer-coupled out to a 500-ohm line. The monitor amplifier consists of an input transformer with a potentiometer across its secondary, into a 6J5 tube. This potentiometer not only controls the voltage on the grid of the next tube, which is a 6F6 tied triode, but also controls the volume level of the monitor speaker and the operators headset. A second potentiometer in the grid of the 6F6 tube controls the volume level of the monitor speaker. On the above chassis is the copper oxide rectifier and relay that controls the stepping relay on the panel and the buzzer. On the same shelf as the above chassis and labelled "D" is the conversion unit chassis.

This unit consists of a resistance-capacity network and two 1:1 hybrid coils. A brief description of this unit which is very important to the frequency response and operation of the equipment is as follows.

The amplifiers will operate over a maximum length of ten miles of telephone line. However, these conversion units plus the amplifiers are designed to work over a seven mile class "C" telephone line or any unbalanced circuit of that length. Whether the line between the Central Station and the Remote Station be a full seven miles or any fraction thereof, the network in the conversion unit will make up the line difference so that to our equipment it still is a seven mile line.

The capacitance of this seven mile line was figured at 0.6 Mfd., and its resistance as 1,344 ohms. Thus each conversion unit (one being used at each end of the line) is divided to have a capacity of 0.3 Mfd. and a resistance of 672 ohms. Each of these units are divided into seven sub-units. There are three 1-mile line units, two 1/2-mile line units, one 1/3-mile line unit and one 1/4-mile line unit. Each of these units is arranged like an "H" pad, as shown in Fig. 5.

Each one-mile line unit consists of four 56-ohm resistors, and a 0.1 Mfd. condenser. Each 1/2-mile line unit consists of four 27-

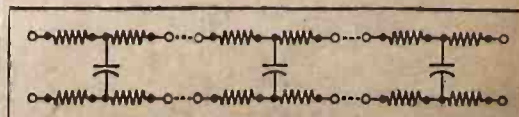

Fig. 5—Three sections of the artificial line.

RADIO-CRAFT'S LIBRARY

presents

4 BEST SELLERS

HERE are four of the handiest, most informative books that this popular technical library ever turned out. They hardly need an introduction. Their usefulness is already an established fact, proven on the best "proving ground" in the world: "The field of practical application."

Yes, indeed, thousands upon thousands of technicians, servicemen, experimenters, trainees use these books daily. They are just the right size to slip in the pocket so you can read them when traveling.

The knowledge gained from these self-help books can be used in countless ways; for example, in building a home-set, when servicing an outside job; or when preparing for an examination. Many men in the armed service who are aiming toward a higher rating are making excellent use of these books. The price, only 50c each, and less when you buy more than one at a time, is trifling when you consider that the first application of the knowledge gained will likely pay the cost of all four books.

No. 25—Home-Made Radio Test Instruments

Outline of Contents: A Low-Cost Signal Chaser—Signal Tracer Test Unit—Simplified Practical Signal Tracer—A Home-Made Infinite Resistance Tube Checker—Build This Direct-Reading V.-T. Voltmeter—How to Make a Modern V.-T. Voltmeter—Measuring High Values of A.C. Voltage and Current With a Low-Range Meter—How to Make a Meter-Range Extender—How to Build a Practical Tube Tester and Set-Analyzer Adapter—The Beginner's Simple Volt-Milliammeter—Build This Simplified Neon-Type Test Unit—Midget Oscilloscope—How to Make and Use a Frequency Wobbler—Double Tracing Your Oscilloscope—Home-Made Frequency Modulator.

No. 26—Modern Battery Radio Sets

Outline of Contents: Beginner's 1-Tube High-Gain All-Wave Receiver—Beginners-Build This 1-Tube Loop Receiver—A "3-in-1" Battery Portable—An Easily-Built "Flewing Superregenerative" 2-in-1 "Card File" Battery Set—A 2-Tube Superhet. With Pentagrid Regenerative 2nd-Detector—The 4-Tube Superhet. Vacation Portable—The "Lunchbox 5" Battery Portable—"The Seafarer" Loop-Type Boat Radio Set—4-Tube Permeability Portable—An All-Purpose Portable—A Typical Commercial 3-Way Portable (Pilot Models X-1452 and X-1453)—Switch for Varying "C" Bias on Battery Radio Sets—Making a Simple Portable Aerial—Making a Pilot-Light Fuse—Old Auto Sets for New Cars—Using a Loop Portable in Cars—Quasi-Electric Soldering Iron—Lamp Bulbs as Resistors.

No. 27—Modern Radio Servicing Technique

Outline of Contents: Elementary Servicing Technique—Correct Procedure for the Servicing Beginner—Elementary Procedure for Servicing Radio Sets—A.F.C. Alignment Made Easy—Dynamic Servicing—Dynamic Testing Simplifies Servicing—Modern Receiver Test Requirements—Servicing Universal A.C.-D.C. Receivers—Servicing "Orphans" and Private-Brand Sets—Emergency Servicing Without Test Meters—Servicing Coils—Servicing R.F. Coils—Servicing Oscillator Coils—General Information—RMA Transformer Color Code—What Causes Echo, Fading?—Radio Service Puzzlers.

No. 28—All About Frequency Modulation

Outline of Contents: The ABC of F.M.—Frequency vs. Amplitude Modulation—Basic Facts About F.M.—Broadcasting—Construction—Build This Practical F.M. Adapter—Audio Amplification—F.M. Audio Amplifier, Part 1—F.M. Audio Amplifier, Part 2—F.M. Audio Amplifier, Part 3—F.M. Service—Part 1, Antenna Installation and Service—Part 2, Receiver Alignment and Diagnosis—Part 3, Test Equipment for F.M. Servicing, Engineering—Part 1, The How and Why of F.M.—Part 2, The How and Why of F.M.—Theory and Design Considerations of R.F. and I.F. Coils in F.M. Receivers.



MAIL THIS COUPON TODAY →

All four books are listed uniformly at 50c each. No discount on less than three books. If you wish to take advantage of our special offer, ordering three books or more, we make an unusual low price to you as follows:
3 books—\$1.25 4 books—\$1.50
(The new increased C.O.D. and postage charges are about 50c. You save this amount by enclosing your remittance with order.)

Do not fail to send coupon today!

RAD-CRAFT PUBLICATIONS, INC.
25 West Broadway, New York 7, N. Y.

RAD-CRAFT PUBLICATIONS, INC. 1-45
25 West Broadway, New York 7, N. Y.

Gentlemen:

Rush to me by return mail, as per your special offer, the following books: (Check books selected.)

- No. 25—HOME-MADE RADIO TEST INSTRUMENTS.
- No. 26—MODERN BATTERY RADIO SETS.
- No. 27—MODERN RADIO SERVICING TECHNIQUE.
- No. 28—ALL ABOUT FREQUENCY MODULATION.

WE CANNOT SEND C.O.D.

NAME PLEASE PRINT CLEARLY

ADDRESS

CITY STATE

Remit by Cash, U.S. new postage stamps, money order, check.

Foreign countries add 20% to all prices quoted.

ohm resistors, and a 0.05 Mfd. condenser. The 1/3-mile line unit consists of four 15-ohm resistors and a 0.02 Mfd. condenser. The 1/4-mile line unit is made up of four 12-ohm resistors and a 0.02 Mfd. condenser. While 27-ohm and 15-ohm resistors do not figure exactly right, as stock resistors were used, they fall within the ten percent tolerance range and are all right for the purpose. There are two controls on the conversion unit, one for the high and one for the low frequencies. These controls peak the line at 100 cycles and 3000 cycles respectively. To equalize the line requires the use of an audio frequency oscillator and a calibrated volume level indicator with the necessary terminating equipment.

The second shelf is a duplicate of the first. On the bottom and labeled "F" may be seen the power supply which feeds the two program amplifier chassis above, including the lights for signalling, stepping relays, etc. The rectifier is a 5U4G used in a full wave circuit.

THE REMOTE INSTALLATION

The Remote Station: In Figs. 3 and 4 can be seen a front and back view of the "Juke Box" used at the remote location. Behind the metal grill at top center is the microphone which the customer uses to tell the operator the number of the phonograph record he or she wants to hear. Either a crystal mike or a small two-inch permanent magnet speaker with an input transformer is used as a microphone. Below this and just above the words "Rhythm-Air" are coin slots for the nickels, dimes and quarters. Behind the three metal bars in front of the Box is the 12-inch, permanent magnet speaker.

A back view of the Box and its interior is shown in Fig. 4. To the left and on the bottom is the power supply with its 5U4G rectifier tube. This is labelled 1. Rear view of the speaker is 3 in the photograph. At top rear middle is the coin scavenger mechanism. This rejects any coin that is not of a non-ferrous nature and also any slugs that might be inserted. Below this and shown with a twin-pair conductor is the coin counting mechanism. This causes one pulse for a nickel, two pulses for a dime and five pulses for a quarter to be sent over the telephone line to the Central Station and operate the stepping relay. The voltage used is anywhere from 30 volts A.C., 60 cycle, to 110 volts A.C. 60 cycle. It depends on the length of the line and other factors, determined by trial.

On the right-hand side and fastened to the wall, labelled D, is the conversion unit. Just below this unit and marked 2, is the chassis containing the remote amplifier. The talk-back amplifier is on this chassis and depending on the type of microphone used, has either a resistance coupled input or transformer coupling to two 6N7 tubes in resistance-capacity coupling, pushpull. The output is transformer coupled to a 500-ohm

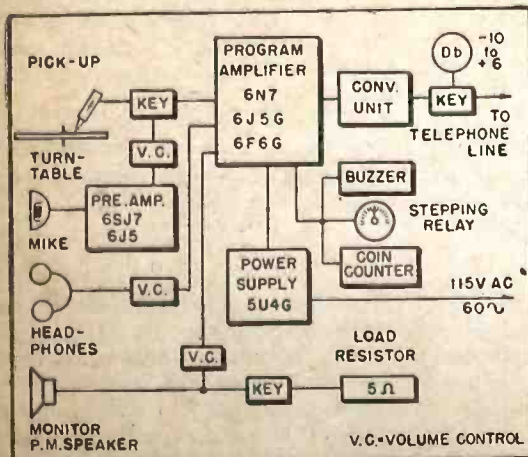

Fig. 6—Rough diagram of the Central Station.

NOW AVAILABLE

Student "MIDGET" KITS FOR AC-DC OPERATION!

The "Student Midget" Kits are now available for AC-DC operation. Similar in every respect, except for the power supply, to the battery operated models. The same progressive building idea has been maintained in making these kits available in the Two and Three tube forms—with the special Add-On kit for converting the Two tube to the Three tube set. Both kits are intended for headphone operation. Uses the same plug-in coils as the battery models. Coil for the BC band is furnished with the kit. Type 76 tubes are used throughout. One of them in each kit being used as a rectifier in the power supply. Tubes not supplied. Detailed instructions furnished.

AC-DC STUDENT KITS

No. 10-1192 Two tube Midget, Net	\$4.20
No. 10-1193 Three tube Midget, Net	4.80

ACCESSORIES

No. 18-2940 70 to 200 meter Plug-in Coil, Net	\$0.40
No. 18-2941 35 to 70 meter Plug-in Coil, Net40
No. 18-2942 17 to 35 meter Plug-in Coil, Net40
No. 18-2944 545 to 1500 meter Plug-in Coil, Net99

Contact our nearest branch, listed below, for rapid delivery.

RADIO ELECTRIC SERVICE CO.

Main Store: N. W. Cor. 7th & Arch Sts., Philadelphia, Pa.

— BRANCHES —
PHILADELPHIA:
3145 N. Broad St., 5135 Market St.
ALLENTOWN, PA.:
1042 Hamilton St.
CAMDEN, N. J.:
513 Cooper St.
WILMINGTON, DEL.:
219 W. 8th St.

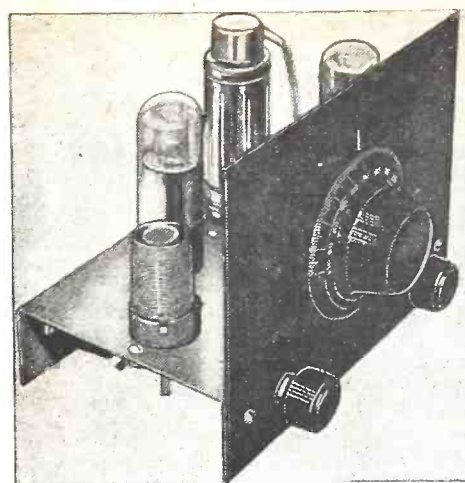

AC-DC MODELS!!!

line. A volume control is used in the grid of the first 6N7 which is a phase inverter for the second 6N7.

The power amplifier for the speaker is a transformer coupled 6N7, with a dual potentiometer volume control across its secondary, resistance-capacity coupled to two 6V6's. These two output tubes are transformer coupled to the speaker. A resistance-capacity filter across the plates of the beam-power tubes flattens out the amplifier response and provides an effective load impedance for all frequencies in the middle and upper range. This is used in place of degenerative feedback. Also on this chassis is a double-pole, single-throw, relay used for signalling the Central Station.

Sometimes the speaker is taken from the "Juke Box" and put in an ornamental baffle. This makes for better intelligibility of speech and quality of music.

A brief description of just what takes place when a coin is inserted in the Remote Location "Juke Box" is as follows: A coin is dropped through the counting mechanism and—depending on its value—causes a contact to close, this operates the double-pole, single throw relay on the Remote Amplifier chassis. When this relay closes it sends the voltage which has been chosen (30 to 110 volts A.C. 60 cycle) from an isolation transformer on the power supply, over the telephone line to the Central Station. When reaching the Central Station this voltage impulse is rectified by a full-wave copper-oxide rectifier and as a D.C. voltage operates the single-pole, single-throw relay on the program amplifier chassis. When this relay closes it operates either the stepping relay on the front panel or the buzzer.

When the operator sees the stepping relay operate or hears the buzzer, she throws the triple-pole, double-throw key between and at the right hand side of the turn-tables.

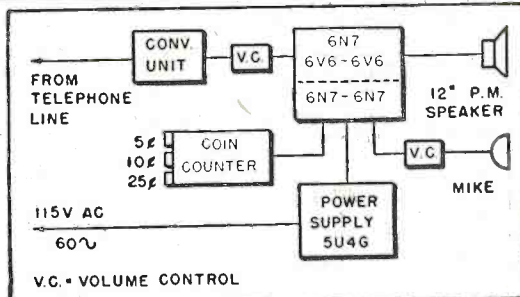

Fig. 7—Block diagram of the remote receiver.

This connects her headset through the monitor amplifier to the incoming telephone line, and also connects the output of the microphone pre-amplifier to the same line. She then can not only hear what record the customer would like to hear played but also talk back to him. If the record is not available, she can ask him to request another. When the operator throws the key to talk to the Remote Station, it automatically drops the level of the phonograph record that might be playing at that time so the customer can hear her voice over the music. A block diagram of the Central Station equipment and also the Remote Station equipment is shown, in Figs. 6 and 7. When the telephone lines are equalized and balanced, their frequency response is within 1/2 Db., from 100 to 6000 cycles.

Nickel-chromium resistance wire, used in modern military radio equipment, is the "smallest component of war." Dissipating up to two watts of power, it is so fine that ninety miles of wire can be drawn from a single pound of alloy.

CONCORD Service!

NONE BETTER IN AMERICA FOR RADIO AND ELECTRONIC PARTS AND EQUIPMENT



Safe! Swift! Satisfactory! That's the story of Concord Radio Corporation's service. Twenty-two years of "delivering the goods" have made us a top supplier of radio and electronic merchandise to industry, government and the trade. Two strategically located "supply bases"—CHICAGO and ATLANTA—are as close to you as a letter, a telephone call, a telegram, or a message on the teletype. Here is what Concord can offer you:



Weston 2 1/2" Model 506 Milliammeter D.C. 0-100
Weston 2 1/2" Model 506 Milliammeter D.C. 0-200
Your Cost, either type \$4.95



IRC Dual Potentiometer 1 1/4" diameter—1 1/2" deep 1/4" shaft—3/4" long
Your Cost 89c



25 mfd. 25 volt condenser in aluminum can.
Your Cost 29c



Micro-Switch, Type Z, S.P.S.T. Normally closed. Acro-Switch, similar to above but normally open.
Your Cost, either type, 79c

- The finest merchandise from the best manufacturers
- Large and complete stocks of components and equipment
- A seasoned selling staff of radio and electronic experts
- Consultant radio technicians and engineers
- Same-day shipment, wherever humanly possible
- Super-speed "special service" for military and industrial needs



FREE! Special Supplement! "Hard-to-Find Radio and Electronic Parts and Equipment" Sixteen pages, jammed to the margins with such items as condensers, wire, switches, volume controls, relays, resistors, test accessories, speakers, etc. There's not another listing like it anywhere in the country today.

CONCORD RADIO CORPORATION
901 W. Jackson Blvd., Chicago 7, Ill. Dept. RC-15

Please rush me the new 16-page "Special Supplement" by Concord Radio Corp

NAME.....

ADDRESS.....

CITY..... STATE.....

CONCORD RADIO CORPORATION
Lafayette Radio Corporation

901 W. Jackson Blvd. CHICAGO 7, ILL. 265 Peachtree Street ATLANTA 3, GA.

CRYSTALS TUNED BY X-RAYS

X-RAYS may have a new use in quartz crystal manufacture, according to Dr. Clifford Frondel of the Reeves Sound Laboratories in New York City. Intense irradiation of the crystals, he said, reduces their frequency of vibration, at the same time turning their color from clear to smoky.

This special X-ray apparatus designed by North American Philips, employs a new high-capacity water-cooled tube that attains the highest possible efficiency. Because the apparatus utilizes an extremely intense beam of X-rays, the problem of protecting the operator from stray radiation was of paramount importance. This difficulty was overcome by using a rotary fixture that exposes one crystal to the beam while another crystal is being loaded into a second holder.

Depending on the original characteristics of the plate, frequency may be lowered in the X-ray unit at a rate of 30 to 50 cycles per second per minute. It is possible to change the frequency of plates in the 6-8 megacycle from 2-3 kilocycles total—this is the saturation value of such crystals. Higher frequency plates can be changed over a larger range.

Dr. Frondel's experiments show that the change in frequency is permanent throughout and beyond any temperature range that the crystal is apt to experience. Actual factory applications of the technique include:—

1. Recovery of over-shot crystals which have been carried too far in finishing.
2. Precise adjustment of standard crystals for use in calibration and in testing.
3. Manufacture of precision crystals for frequency and time standards. A crystal which is considered stable can be precisely adjusted to final frequency by this method without the possibility of further aging.
4. Adjustment of frequency of a standard crystal at a given temperature.

X-rays are not new to the crystal indus-

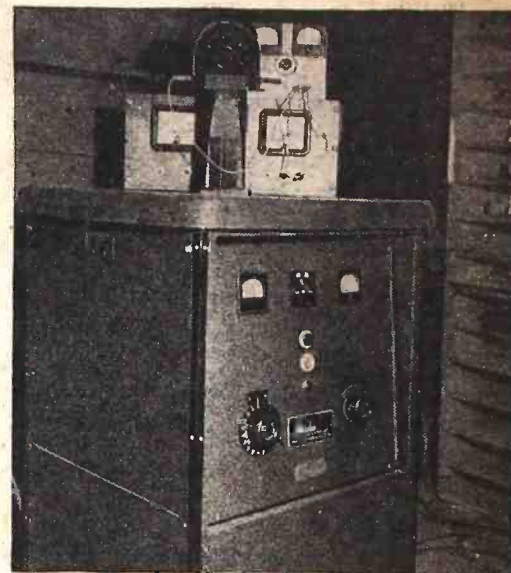

The X-ray apparatus used to tune crystals.

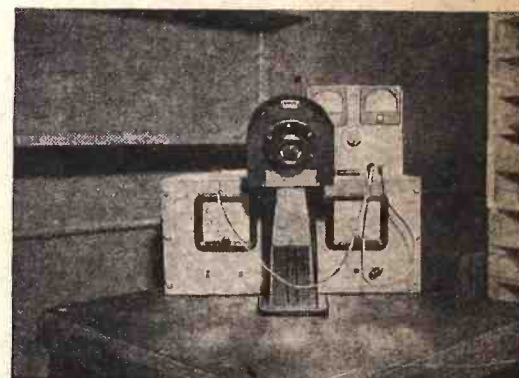

Photos courtesy North American Philips

Close-up of the crystal-tuning equipment.

try, as they are in steady use for determining the orientation of the plates.

ROLL YOUR OWN TRANSFORMER!

SOMETIMES a new transformer is needed when that particular transformer is not available. By looking through your junk box you may be able to make your own, either for replacement or "made to order" for a special need.

Recently, I needed a power transformer with a 6.3 volt filament winding for a set. (I originally built the set and the power transformer was a very husky one—much too heavy for the set in question. I used the heavy transformer for a push-pull 6L6 guitar amplifier.) In my junk box I had a small transformer. It had a high voltage winding, a 5 volt winding for rectifier, and two more filament windings, each one being 2.5 volts.

I decided to rewind the filament winding, so carefully disassembled the transformer, taking care not to damage any of the windings or bend any of the laminations. A detailed explanation of taking the transformer apart and unwinding the filament windings can be found in the September, 1942, issue of *Radio-Craft*.

Number 1 filament winding (5 volt-rectifier) had eighteen turns (C.T.) of No. 17 wire. Number 2 filament (2.5 v.) had nine turns (C.T.) of No. 19 wire. Both windings were on the same layer. Number 3 filament (2.5 v.) had nine double turns of No. 17.

Now came the rewinding. I decided to try to get 12.6 volts, not just 6.3 volts, so that I could use a 12SQ7 to replace a bad 6SQ7. Also, other occasions might arise in

the future where it would be advantageous to have 12 volts available.

A search through the junk box yielded an old choke wound with No. 18, which was just the size needed. As there are 3.6 turns per volt (9 v./2.5 t, or 5 v./18 t) twenty-four turns were needed for the 6.3 winding and there was enough space to put on thirty-six turns, which made 10 volts. Winding was tapped at twelve turns and twenty-four turns. To get 12.6 volts the number 2 filament of 2.5 volts was connected in series with the new 10 volt winding.

The transformer was carefully reassembled and checked for possible shorts and being found O.K. was hooked up to the house line and voltages checked with an A.C. voltmeter. Voltages were as expected.

Next time you can't locate just the transformer you need, try building your own—custom-made to fit the job on hand.

Roy T. HORTON,
Woodside, N. Y.

Effective, reliable home and office type radio facsimile recorder capable of printing news at the rate of several hundred words a minute and pictures equal in quality to the best found in newspapers will come in the early post-war period, says E. W. Engstrom, Research Director of RCA Laboratories.

1	2	3	4
5	6	7	8
9	10	11	12
13	14	15	16

ELECTRONIC Puzzle Square

By
LT. C. K. JOHNSON

Here is a new idea in a Magic Square. Work problem No. 1 and put the answer in square No. 1. The answer to problem 2 goes in square 2, etc. When all 16 problems are completed, the rows, columns diagonals and various other combinations will total a number which is the type number of a popular power amplifier triode frequently used push-pull to give a power output of about 18 watts with 275 volts on the plate.

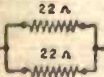
1.  The total resistance between A and B is — ohms.

2. On a slide rule, 64 on the right hand side of the A scale is directly over — on the D scale.

3. The pentode is a — element tube.

4. $21.18/8.1^\circ$ would equal — $+3j$ in rectangular coordinates.

5. If a regular hexagon is inscribed in a circle whose radius is one inch, the perimeter of the hexagon is — inches.

6. What is the voltage between A and B?

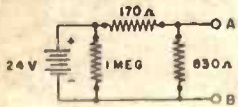

7. Two 12 volt batteries hooked in parallel will give — volts.

8. .142857 is the reciprocal of —.

9. B and S gage bare copper wire No. — has a circular mil area of 1,288 and at 25 C.

10. To find wavelength in meters when frequency in kilocycles is known, we have a formula $\lambda = \frac{C \times 10^5}{f}$. What digit does C

replace?

11. In the R.M.A. color code, silver represents a tolerance of what percent?

12. What is the total capacitance in mfd.

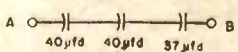
between A and B? 

13. Effective voltage (in alternating current of sine-wave form) is to average voltage as 10 is to —.

14. What will be the voltage across the 1-megohm resistor exactly 1.967 seconds after the switch (S_1) is closed, allowing current to enter the resistor - condenser combination?

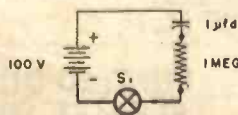

15. In this circuit the problem is to find the current in milliamperes if 1.62 watts is dissipated in the 500-ohm resistor.



16. Yellow is — in the color code. (See Page 243 for Answers)

The electrophorus, or electric eel, is capable of discharging nearly 3,000 watts at voltages from 200 to 500. The "jolts" are delivered in pulses lasting little over a thousandth of a second. Electrophorus uses his high-voltage installation to stun his prey as well as in self-defense.

HALLICRAFTERS ★ HALLICRAFTERS



RECEIVER HEADQUARTERS for the Nation

BEFORE the war Bob Henry served the amateurs as the world's largest distributor of communications receivers.

Now Henry Radio is Hallicrafters receiver headquarters for the Nation at war. Hallicrafters Receivers can be supplied on AA-1 priority. I can usually supply SX28As at \$223.00, SX-25s at \$94.50, and PM-23 speakers at \$15.00 at once. It takes longer to supply other models.

Soon, it is hoped, non-priority orders can be filled and Bob Henry can become again Hallicrafters headquarters for the nation at peace.

I have stores at Butler, Missouri, and at 2335 Westwood Blvd., Los Angeles 25, Calif.

Your orders and inquiries are invited.

Bob Henry, W9ARA
HENRY RADIO SHOPS

Butler, Mo. and Los Angeles, 25, Calif.

COMPLETE STOCKS

I have in stock some Hallicrafters receivers available for immediate delivery on priority and the following parts without priority: meter rectifiers \$1.95, transmitting tubes, transformers, resistors, condensers, panels, headsets, etc. Your orders and inquiries invited.

"WORLD'S LARGEST DISTRIBUTOR OF COMMUNICATIONS RECEIVERS"

PERMANENT WAVE MACHINE FOR RAYON

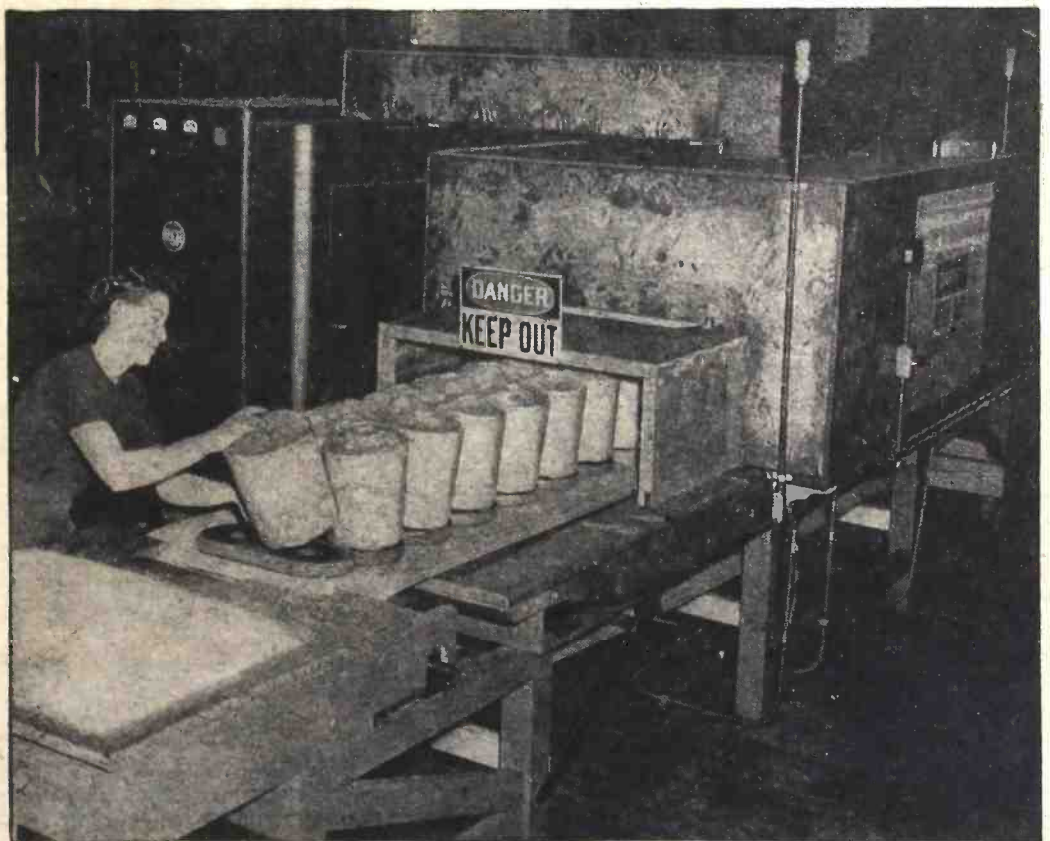

Permanent waves given to rayon tire cord in this electronic heating installation sets the twist and makes tires wear better. The scene was photographed in the Goodrich cord plant at Silvertown, Ga., and shows the RCA 15-kw. electronic power generator in use. High-frequency power supplied by the generator is applied to electrodes shielded within the copper housing which encloses a section of the conveyor belt. A solid plate electrode is located under the belt, while a copper gauze electrode is positioned so as to just clear the tops of the moving spools of cord. At left a girl operator, standing in front of the generator, is seen placing large spools, individually wrapped in moisture-proof paper, on the belt.

Learn RADIO-ELECTRONICS-TELEVISION



12 WEEKS TRAINING IN COYNE SHOPS WHERE YOU "LEARN-BY-DOING"

Trained Radio-Electronics men needed now. They will be needed too when the war is over. Tremendous expansion in Radio, Electronics, Frequency Modulation and Television predicted—a world of new opportunities. Get Radio Training in the Coyne Shops in Chicago now, and BE READY!

Ill Finance Your Training

If you are short of money, you can start now and pay most of your tuition after you graduate. Many earn while learning. Free Lifetime Employment Service to graduates. **EXTRA training in INDUSTRIAL ELECTRONICS—no extra cost.**

Men with Physical Disabilities—we have special facilities for you. If you have a physical disability of any kind write me when you send coupon.

FREE BOOK! Whether you're 16 or up to 40, get the facts. Big illustrated book tells about your future in Radio-Electronics-Television. Mail coupon today.

H. C. LEWIS, Pres., RADIO-ELECTRONICS DIVISION COYNE ELECTRICAL SCHOOL, 500 S. Paulina St., Dept. 15-7M, Chicago 12, Illinois. Send me FREE BOOK on COYNE RADIO-ELECTRONICS-TELEVISION TRAINING, extra Industrial Electronics course, and details of "Pay-After-Graduation" Plan.

NAME

ADDRESS

CITY.....ZONE.....STATE.....

Be Your Own Boss!

START A GOOD-PAYING BUSINESS!

Stop worrying about a post-war job. Why let yourself be pushed around by economic conditions, as business slows down—when you can run your own so easily? We will show you how!

Get started at once with the aid of "CASH IN," the amazing short-cut guide to success. It contains

300 WAYS TO MAKE MONEY

It shows you how to begin—either in a small way in your own home and branch out big—or how to open a shop at once with profits rolling in immediately. It's chock full, from cover to cover, with tested money-making plans, formulas, business secrets, and sure-fire success schemes.

You can start with as little as a few dollars' capital. All you need to do is pick out the one business that appeals to you most—follow the simple directions—and then go to it!

66 PAGES — 40,000 WORDS IN TEXT

Send for "CASH IN" today. Enclose 25c, that's all—you won't be asked for another cent—now or later. Sold on a money-back guarantee. **25c**

NATIONAL PLANS INSTITUTE

P. O. Box 26R, Station N, New York 23, N. Y.

PATENTS—TRADE MARKS

Booklet concerning Inventions & Patents Form "Evidence of Conception" with instructions for use and "Schedule of Government and Attorneys Fees"—Free LANCASTER, ALLWINE & ROMMEL Registered Patent Attorneys

436 Bowen Bldg. Washington 5, D. C.

Guaranteed Rebuilt Radio VIBRATORS—\$1.00 ea.

Send old vibrator. For very prompt delivery, enclose remittance and return postage. We rebuild any make or kind of vibrator or relay. Vibrator packs rebuilt also. Send your old vibrator to

BEST VIBRATOR CO., Box 5802-Z, Cleveland 1, O.

ELECTRONIC SYMBOLS

(Continued from page 215)

instead of three, as has been the situation since the coordinated symbols were published. We are therefore beginning the new symbols in this issue, and as soon as diagrams already made up are finished, will use the coordinated system exclusively.

The best interests of radio and electronics will be served if every forward-looking publisher, engineer and draftsman takes such steps toward rationalization and coordination as may now be taken, meanwhile pressing for a post-war conference at which the schematic problem may be considered more deliberately. The best features of the present systems can then be coordinated into a group of electronic symbols which will combine as many of the advantages of each as may be possible.

Another important task of a post-war conference will be the establishment of new symbols necessitated by the advances of electronics during the war period. A thorough review of the present list with the object of bringing standard symbols into line with actual usage and practice, might well be undertaken. Such a course of action would finally eliminate all confusion and achieve a standard set of symbols.

ELECTRONIC GUITARS

(Continued from page 217)

Since the gain of such amplifiers will be high, it is important to choose tubes which have a low level of microphonic response. Experimenting with a number of ordinary production tubes and choosing the least

This simplest of tone-control systems works well in cutting excessive highs and various extraneous noises which might otherwise mar the tone quality.

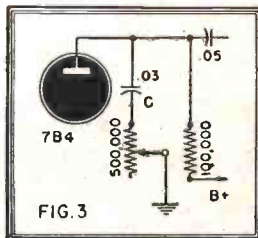

microphonic amongst the lot will lead to best results. In this amplifier no tone control system is used. A tone control could easily be added, however. Connecting a .05 condenser to the 7B4 plate and the other end to the high side of a 1 megohm, as shown in Fig. 3, adequate tone control can be secured. If desired, various values of C can be tried until best results are secured.

Seven thousand miles of coaxial cables will carry 480 simultaneous telephone conversations, as well as television images, from coast to coast, Harold S. Osborne of the American Telephone and Telegraph Co. tells the Society of Motion Picture Engineers recently.

Laying of the cable is in progress between Terre Haute, Indiana, and St. Louis, Missouri. The network should be completed in about five years. Cost of the installation will be high. It is estimated that a single coaxial cable between New York and San Francisco would run to \$20,000,000.

The electron microscope, now able to magnify about 20,000 times, may in the future be perfected to achieve magnifications as high as 2,000,000 diameters, according to Drs. Zworykin and Hillier, co-developers of the RCA electron microscope.

FOR SALE HARD-TO-GET ITEMS

All items are brand new, except where indicated. ALL are in PERFECT WORKING ORDER. In many cases, the parts alone total more than the price we are asking. Satisfaction guaranteed or your money back. ORDER FROM THIS PAGE. Use our convenient coupon. Include sufficient extra remittance for parcel post charges, otherwise order is sent express collect. Any excess will be refunded. All C.O.D. shipments require 20% deposit. No C.O.D. shipments on orders for less than \$5.00. If full remittance accompanies order deduct 2% discount. Send money order, certified check, or new U. S. stamps. No C. O. D.'s to foreign countries.

ULTRA MAGNET

LIFTS MORE THAN 20 TIMES ITS OWN WEIGHT

LITTLE GIANT MAGNET

Lifts 5 lbs. easily. Weighs 4 oz. Made of ALNICO new high-magnetic steel. Complete with keeper. World's most powerful magnet ever made. The experimenter and hobbyist will find hundreds of excellent uses for this high quality permanent magnet. Measures 1 3/4" x 1 1/4" Shp. Wt. 3/4 lbs. ITEM NO. 159 YOUR PRICE \$1.50



GENUINE MICROPHONE TRANSMITTERS

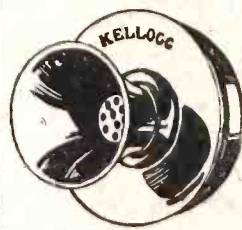

These are regular "telephone transmitters" of the type used on wall telephones. Taken from a large telephone supply company's overstock, these fine mikes offer a grand opportunity to obtain a splendid unit for little more than the price usually asked for a simple "microphone button."

The amateur, experimenter and telephone mechanic will find a variety of uses for these excellent microphones. They work perfectly on 2 dry cells.

Can be used on P.A. systems for voice transmissions, in call systems and intercommunications sets. With telephone receivers (radio headphones will do) they may be made into short-line telephone circuits, such as house-to-house or farm-to-farm "phone lines. You can use them to talk through your own radio, or as concealed dictaphone pick-up units for listening to conversations in a distant room or building. The telephone mechanic will find them useful replacements on battery-operated rural telephone lines.

THESE ARE GENUINE TRANSMITTERS. MADE BY KELLOGG, WESTERN ELECTRIC AND STROMBERG-CARLSON, excellent in appearance and operation. A remarkable value, and one seldom offered in these times. Shp. Wt. 1 lb. ITEM NO. 160 YOUR PRICE \$1.50

AMAZING BLACK LIGHT!!

Powerful 250-Watt Ultra-Violet Source



The best and most practical source of ultra-violet light for general experimental and entertainment use. Makes all fluorescent substances brilliantly luminescent. No transformers of any kind needed. Fits any standard lamp socket. Made with special filter glass permitting only ultra-violet rays to come through. Brings out beautiful opalescent hues in various types of materials. Swell for amateur parties, plays, etc., to obtain unique lighting effects. Built

only. Shp. Wt. 1 lb. ITEM NO. 87 YOUR PRICE \$2.45

WATTHOUR METER

Completely overhauled and ready for immediate service. Designed for regular 110-volt, 60 cycle 2-wire A.C. circuit. Servicemen use it in their shops to check current consumption of sets, soldering irons, etc. Keeps costs down. If dismantled, parts alone would bring the price. The elaborate gear train could be used as a counter on machines of various kinds. Simple to install: 2 wires from the line and 2 wires to the load. Sturdily constructed in heavy metal case. 8 1/2" high, 6 1/4" wide, 5" deep. Westinghouse, G. E., Ft. Wayne, Sangamo or other available make. Shp. Wt. 14 lbs. ITEM NO. 33 YOUR PRICE \$5.95



LIMITED QUANTITIES! PROMPT SHIPMENTS!

It's Easy to Order—Clip Coupon—Order from This Page—No Catalog Sent.

MAIL TODAY—NOW!

(See Corresponding Ad Page 249)

HUDSON SPECIALTIES CO. 40 West Broadway, Dept. RC-1-45, New York 7, N. Y.

I have circled below the numbers of the items I'm ordering. My full remittance of \$..... (include shipping charges) is enclosed (NO C.O.D. ORDERS UNLESS ACCOMPANIED WITH A DEPOSIT.) OR my deposit of \$..... is enclosed (20% required; ship order C.O.D. for balance. NO C.O.D. ORDER FOR LESS THAN \$5.00. (New U. S. stamps, check or money order accepted.) Circle Item No. wanted: 33 87 159 160

Name

Address Please Print Clearly

City State

Send remittance by check, stamps or money order; register letter if you send cash or stamps.

?? WHY NOT ??

Have you ever asked yourself, "Why can't I have this or that gadget on a radio? Why aren't programs made to fill such and such a need?" If so, you are a charter member of the *Radio-Craft* "Why Not" club. Send us your "Why Not's" on all subjects—serious or screwball, practical or idealistic. We will pay \$1.00 for every one we believe will interest the readers of *Radio-Craft*.

You can get the idea from the "Why Not's" printed below. Send in as many as you like. One dollar will be paid for each one printed.

Why not have some means of keeping too-long cords on radio sets from getting in the way where you trip over them or getting tangled up, kinking and giving trouble? Why couldn't manufacturers adopt one of the two following ideas?

Have a reel like a window shade roller, which would automatically take up the slack of the cord.

Have two plastic or other type hooks in the back of the set on which to wind the excess cord.—*O. F. Miller, Portland, Oregon.*

Why not a campaign to teach people the importance of good aerials in getting decent, interference-free radio reception? The Serviceman can hardly sympathize with a customer using a loop-set in an iron-frame building which cuts the signals from broadcast stations down to about one-tenth their power and lets interference originating inside the building come through at full strength. With an outside aerial the situation would be reversed, but few set-owners know it. If such an aerial is suggested, the Serviceman is immediately suspected of attempted profiteering.—*Frank Knox, Chicago, Ill.*

Why not a robot soldering-iron extension cord for home servicing? One that would dash under sofas, into obscure corners, behind bookcases, etc., and plug itself into the nearest receptacle! Then home servicing could cease to be a combination of obstacle racing and furniture moving.—*M. Funk, Montreal, Can.*

Why not have a radio you could set each morning for all the programs you wish to hear during the day? Then all you would have to do would be to wait till the programs come in by themselves. If no program were indicated at any given time, the radio would automatically turn itself off, and when the time for the next program listed came up, would go on again.—*Alex McAskill, St. Paul, Minn.*

11	8	5	21
6	20	12	7
19	3	10	13
9	14	18	4

ANSWERS TO ELECTRONIC PUZZLE

(Page 241)

The numbers add up to 45 in every direction, if answers are correct.

Why not a radio with a connection which would enable the listener to ask questions on a program? This would be especially efficacious during debate broadcasts, and might be used for criticism as well.—*Arthur Gordon, New York City.*



THERMOSTATIC METAL TYPE DELAY RELAYS PROVIDE DELAYS RANGING FROM 1 TO 120 SECONDS

Other important features include:—

1. Compensated for ambient temperature changes from -40° to 110° F.
2. Contact ratings up to 115V-10a AC.
3. Hermetically sealed — not affected by altitude, moisture or other climate changes . . . Explosion-proof.
4. Octal radio base for easy replacement.
5. Compact, light, rugged, inexpensive.
6. Circuits available: SPST Normally Open; SPST Normally Closed.

WHAT'S YOUR PROBLEM? Send for "Special Problem Sheet" and Descriptive Bulletin.

AMPERITE CO. 561 BROADWAY
NEW YORK 12, N. Y.

In Canada: Atlas Radio Corp., Ltd.
560 King St. W., Toronto

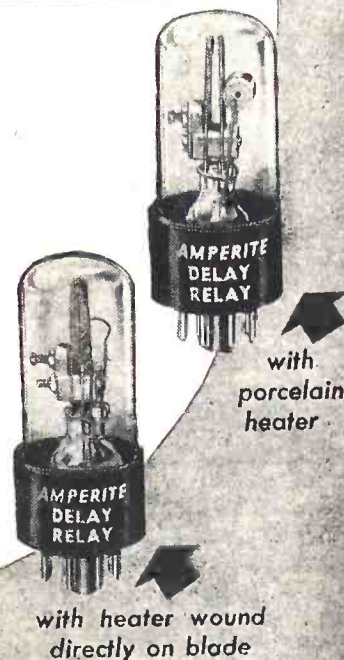

SOLDERING CAN DAMAGE FINE WIRE

HIGH-TEMPERATURE molten solder's may have a very destructive effect on copper wire. The combined process of stripping of and tinning such wires by dipping in solder of high temperature produces the worst effects.

Experiments by engineers of Fairchild Camera and Instrument Co. indicate that the hot solder dip method may seriously reduce the diameter of fine wires, as well as increase the metal's brittleness. Wire sizes ranged from No. 29 to No. 40, all Heavy Formex insulated. The usual practice has been to use solder at a temperature of 1025 to 1100 degrees Fahrenheit. The wire dipped into this solution has its insulation removed by the heated metal and is tinned at the same time.

If the wire is kept in the hot solder long enough, the submerged section is completely eaten away. "Long enough" tends toward understatement—for No. 29 the period is about 20 seconds, and for No. 40 only 6 seconds. The tinning process for No. 29 takes only 10 seconds, leaving a fair safety margin, but No. 40 is destroyed practically as the stripping and tinning are completed.

Cause of the destruction appears to be that the copper enters into the molten solder, in the form of an alloy chiefly with the tin, but also to some extent with the copper. Embrittlement is also partly due to the same effect, as photo-micrographs show a new constituent—possibly of copper-tin alloy—between the solder and the copper zones in some of the wires treated. The effect of heat—in the form of a coarsening of the copper crystals near the surface of the wire—was also noted from the same photographs.

Conclusions drawn by the Fairchild scientists were that a low temperature solder

should be used on fine wires and the operating point should be near 600 degrees for ordinary soft solders. It is also noted that a softer solder, preferably a 40/60 combination, has the least effect on wire undergoing the tinning process, though practical considerations may call for the use of other types of solder.

Lithium, lightest of all metals, weighing only one-fifth as much as aluminum, promises to have many post-war industrial applications. This silver-white metal, that occurs more plentifully in the earth than lead or tin, is used in high-conductivity copper castings, tin bronzes, silicon bronzes, aluminum welding, magnesium melting and casting, and in the heat-treating of metals.

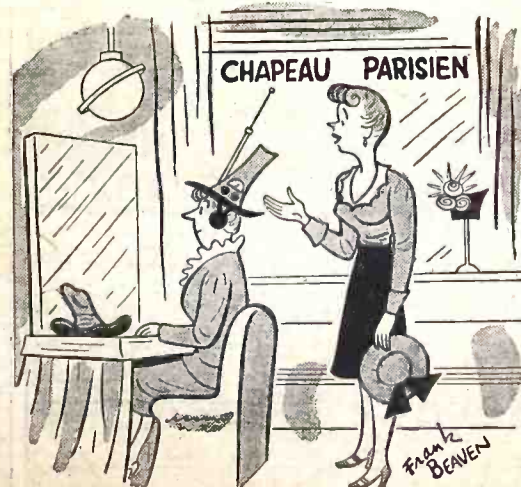

"Now this model, we call a 'Hattie Talkie'!"

The Book that takes Drudgery out of Mathematics

Only **50¢** postpaid

Entire Chapter on Special Mathematics for the Radio Technician.

ELEMENTARY MATHEMATICS

● EASY — SIMPLIFIED — PRACTICAL ●

Here is the book that gives you a good background in mathematics; that takes all the irritation and drudgery out of it. You don't need to be scared of mathematics, because here's the subject explained without frills, without useless computations.

CONTENTS OF BOOK

CHAPTER I. Arithmetic—Addition—Subtraction—Multiplication—Division.
 CHAPTER II. Factoring and Cancellation—Fractions—Decimals—Percentage—Ratio and Proportion.
 CHAPTER III. The Metric System.
 CHAPTER IV. How to Measure Surfaces and Capacity (Geometry).
 CHAPTER V. Powers and Involution—Roots and Evolution.
 CHAPTER VI. Mathematics for the Manual and Technical Craftsman—Thermometer conversions—Graphs or Curve Plotting—Logarithms—Use of the Slide Rule.
 CHAPTER VII. Special Mathematics for the Radio Technician.
 CHAPTER VIII. Commercial Calculations—Interest—Discounts—Short Cut Arithmetic.
 CHAPTER IX. Weights and Measures—Useful Tables.

ONLY **50c** POSTPAID

Send today for your copy of this indispensable book. It can be carried readily in your pocket. (Size 6 x 9 in.)

Send Stamps, Cash or Money Order to

TECHNIFAX

1917 S. STATE ST., RC-1-45, Chicago, Ill.

TECHNIFAX 1917 S. State St., Chicago, Ill.

Enclosed herewith 50 cents, for which mail to address below your ELEMENTARY MATHEMATICS.

NAME

ADDRESS

CITY STATE.....

RC-1-45

FADA Permanent NEEDLES

List \$1.00

Special Introductory Offer 39¢

(TO DEALERS ONLY—IN LOTS OF 6 OR OVER)

- Plays 4M Records without changing
- Better Tone Reproduction
- Help Reduce Background Hiss
- Longer Record Life

FADA OF NEW YORK
 928 BROADWAY NEW YORK 10 N. Y.
 Large Stock of Replacement Parts and Cabinets

TRAIN FOR RADIO ELECTRONICS — 12 WEEKS SHOP TRAINING

I WILL FINANCE YOUR TRAINING

Trained Radio-Electronics men needed today, and they will be needed after the war. Prepare for the great opportunities now in Radio-Electronics and Television. "Learn by Doing." Free employment service for life after graduation. You can "Earn while learning". I'll finance your training if you are short of money. Mail coupon today for all details and big free book. We have facilities for men with physical disabilities. If you have a physical disability of any kind write me when you send the coupon.

H. C. Lewis, Pres., Radio-Electronics Div., Coyne Electrical School, Dept. 15-8H, 500 S. Paulina St., Chicago 12, Ill.
 Send free book and full details.

NAME _____
 ADDRESS _____
 CITY _____ ZONE _____ STATE _____

DOUBLING UP ON THE 1H5-GT

THE modern small radio receiver has been made possible largely through the development of multi-element tubes which combine two or more tube functions inside a single envelope. The pentagrid converter and the diode-triode second detector are familiar to all radio men. Tubes of this type because of their convenience and efficiency have been incorporated in the design of many large communications receivers where the saving of space is not a primary consideration.

Multi-element tubes offer great possibilities to a resourceful radio engineer for applications entirely apart from those for which they were originally designed. An interesting example of such uses is found in the new Hallicrafters, S-39 battery or A.C./D.C. operated portable communications receiver. Because of its small size and the fact that it must include all of the operating features of a standard communications receiver, the S-39 presented an ideal opportunity for an unusual new tube application.

Communications receivers of modern design must incorporate a c.w. oscillator and an automatic noise limiter. In the Hallicrafters S-39 these two functions are combined in a single 1H5GT tube which was originally designed to be used as a diode detector and first audio stage. The accompanying partial diagram of the S-39 shows how this tube performs these two separate functions. The diode section is used as a peak limiter to reduce noise from ignition, static, etc., and the triode section operates as an adjustable intermediate frequency oscillator to permit reception of c.w. telegraph signals. Either section may be used independently of the other, making the receiver adaptable to a variety of conditions.

In common with all Hallicrafters radio equipment, the present production run of the new S-39 receiver is entirely for military use.

Key to Diagram:

V1—1H5GT second detector and first audio amplifier
 V2—1H5GT automatic noise limiter and beat frequency oscillator
 SW1—automatic noise limiter switch
 SW2—beat frequency oscillator switch

Resistors

R1—audio volume control. 1/2 megohm variable carbon resistor
 R2—100,000 ohms 1/4 watt carbon
 R3—10 megohm 1/4 watt carbon
 R4—470,000 ohms 1/4 watt carbon
 R5—100,000 ohms 1/4 watt carbon
 R6—47,000 ohms 1/4 watt carbon
 R7—47,000 ohms 1/4 watt carbon
 R8—1.5 megohm 1/4 watt carbon

Condensers

Capacity	Working Voltage	Dielectric
C1—85 mmf		
C2—100 mmf	500	mica
C3—240 mmf	500	mica
C4—.004 mfd.	600	paper
C5—3 turns, twisted wire leads		
C6—1 mfd	200	paper
C7—100 mmf	500	paper
C8—.02 mfd	400	paper
C9—100 mmf	500	mica
C10—510 mmf	500	mica
C11—.01 mfd	200	paper

"It's Smart to Be Safe," but a Canadian motorist discovered recently that one can pay too much attention to safety. Rushing home to dinner, he tuned his car radio to the ABC (Always Be Careful) program on CJCA at Edmonton, Alberta. He became so interested in the program that he ignored a traffic light and crashed. After the accident, the radio continued to talk from the ruined car, giving advice on how to drive carefully.

Radio has proved its efficiency in detection, communication, and actual suppression of forest fires in the National Forests of Utah, says a recent report of the United States Grazing Bureau.

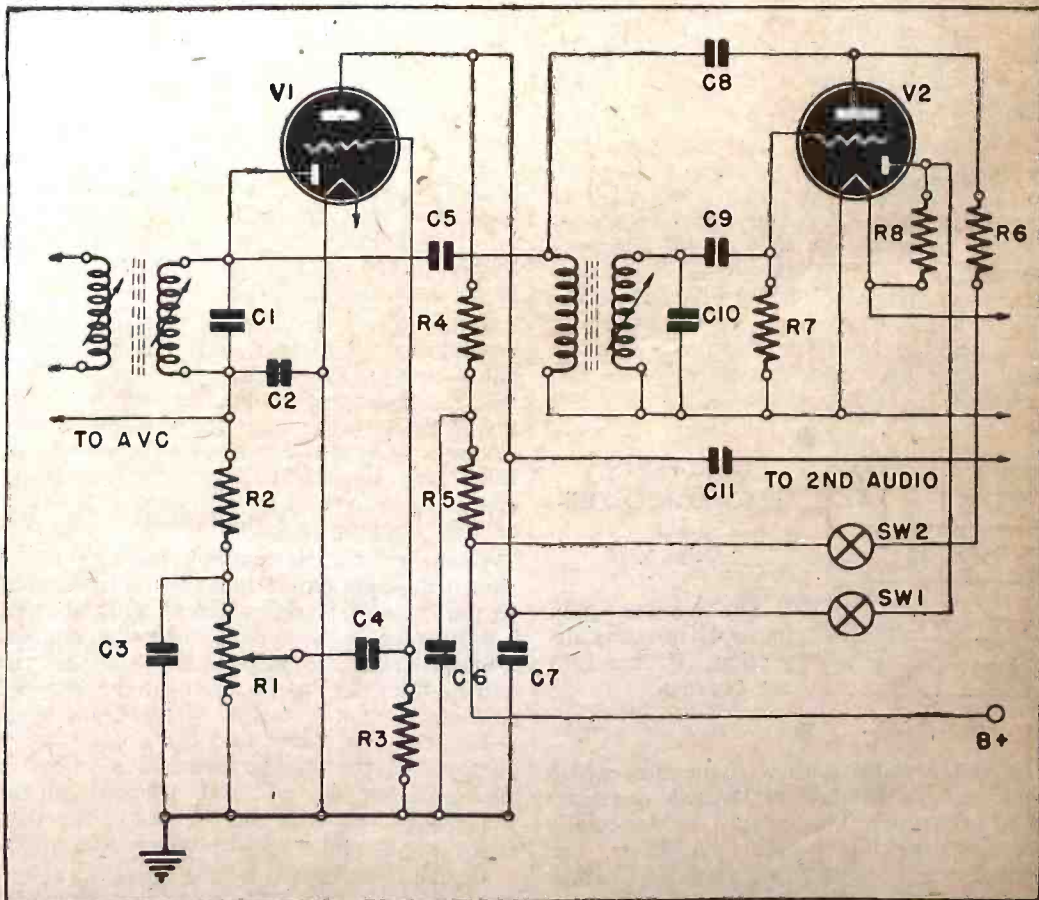

A MILITARY HEADSET

Example of the successful conversion of specialized civilian equipment to meet military needs is the headset used in tanks. Manufactured by Telex, long experienced in hearing aids, it combines the sensitivity and ultra-compactness of the peace-time instrument with a ruggedness built-in for its present combat use. To meet Army requirements the receivers must pass tests more severe than anything they would ever be subjected to in non-military use. Operation must be satisfactory at all temperatures between 40 degrees below zero (Fahrenheit) to 180 degrees above. In addition the phones must stand a short test on 350 volts A.C. applied for one minute between coils and frame, as well as severe mechanical tests.

Technical specifications of the "Tiny but Tough" instruments are:

Impedance—up to 5,000 ohms.

Cubic Volume—approximately 0.3 cu. in.

Sensitivity—18 dynes/sq. cm. for 10 microwatt input.

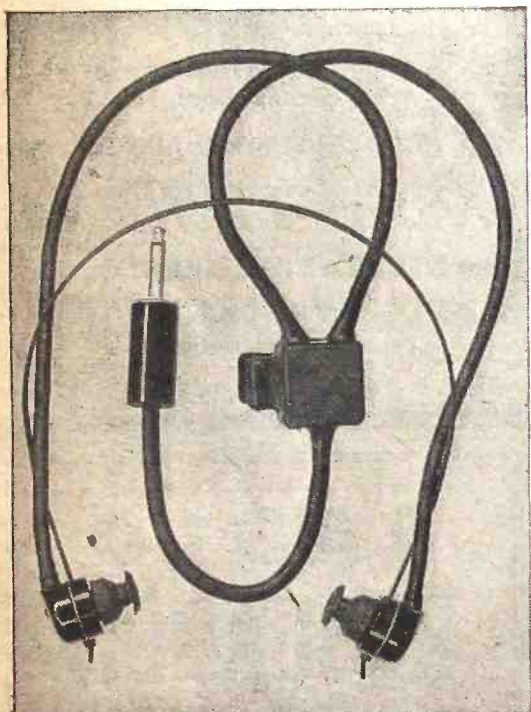
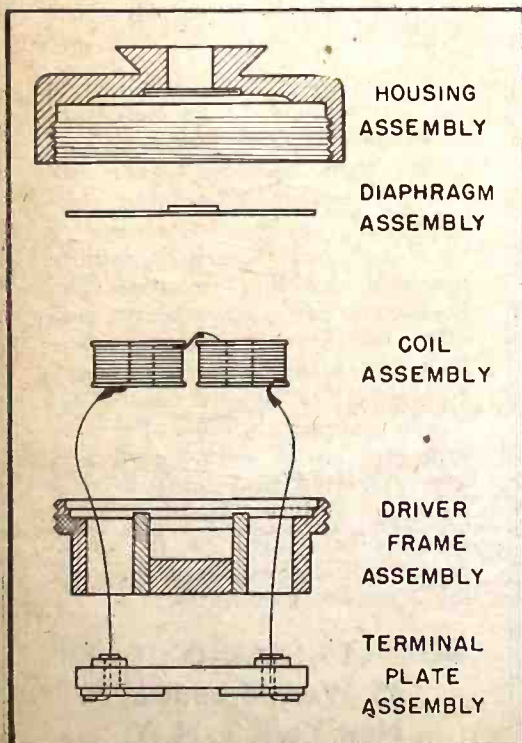

Photo of the rugged miniature Army headset.



Drawing in detail of one of the earpieces.



OPPORTUNITY

for men with a knowledge of COMMUNICATIONS EQUIPMENT

★ Help your country and yourself. A war plant making vital equipment for the Army, Navy, Air Force, and Coast Guard is in urgent need of personnel with knowledge of communications equipment to become:

ELECTRICAL INSPECTORS
MECHANICAL INSPECTORS
INSTALLATION SUPERVISORS
JUNIOR ENGINEERS
LABORATORY ASSISTANTS
DRAFTSMEN

JOBS EVERYWHERE — some at factory; others at military and naval centers throughout country. Plant is located in the Chicago area. Modern equipment, excellent working conditions, old established firm, promising future after war.

FREE TRAINING: Experts teach you quickly at no cost. Earn while you learn.

WRITE FOR DETAILS: Will be sent on receipt of your letter, stating experience, education, age, references, draft status.

Do Not Apply if 100% in War Work!

Our entire personnel knows of this advertisement

WRITE BOX 105 C/O RADIO-CRAFT
25 West Broadway, New York, N. Y.

TWO-WAY RADIO communication for intercity busses was forecast by representatives of the National Association of Motor Bus Operators, appearing last month before the FCC to request assignment of 15 frequencies to the industry.

Testimony was heard from spokesmen for several major inter-city bus lines who are members of a subcommittee of the Radio Technical Planning Board. They declared that ability to communicate with buses on the highways and to receive messages from drivers would facilitate passenger travel,

promote safety, minimize delays in the event of road failures and expedite repair and maintenance work.

It was reported that already some of the bus lines plan to install experimental equipment on certain routes as soon as wartime restrictions are lifted.

In the current hearings before the FCC, the intercity bus operators are one of 17 governmental and commercial groups requesting designation of wave bands for post-war development of radio communication.

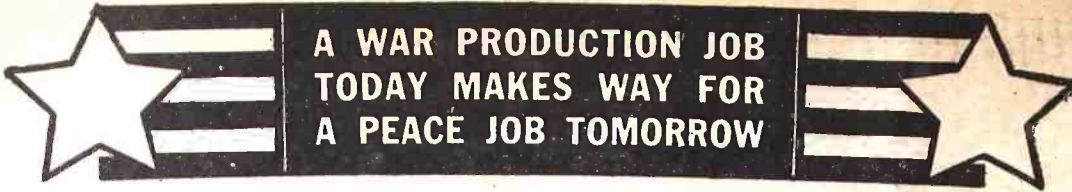

IS *Your* OPPORTUNITY HERE?

Think this over carefully. Where do you go from the spot you're in now? Are your surroundings friendly and full of promise for the future? Consider now the place you might fill in the electronic industry leadership assured to the fine staff of engineers, scientists, technicians at NATIONAL UNION RADIO CORPORATION. We're all young in years and ideas though most of us are old in electronic experience. We enjoy working together. We know we're going places! We're inviting you to join us if you have the qualifications. If you're looking for a success pattern for your future, it may be here with us at National Union. Find out! Come in and talk it over or write us!

NATIONAL UNION WANTS:

- * **QUALITY CONTROL ENGINEER AND SENIOR TUBE ENGINEERS**—These men MUST have executive ability and extensive experience with radio tube manufacture. The pay and opportunities are commensurate with your ability.
- * **COMMERCIAL ENGINEERS**—Men with pleasing personalities, initiative and a knowledge of vacuum tube applications.
- * **QUALITY CONTROL MEN**—Statistical Training is chief requirement though a knowledge of vacuum tubes will help.
- * **JUNIOR ENGINEERS—MEN or WOMEN**—If you have a college degree in Physics, Electrical Engineering, Mathematics or Chemistry and are the type of young person who is able to 'go places,' you'll be starting with your best foot forward if you are accepted at National Union Radio Corporation.
- * **FOREMEN and ASSISTANT FOREMEN**—Men with foremanship experience in exhaust, stem or grid operations in radio tube manufacture.
- * **TECHNICIANS, CIRCUIT MEN**—Maybe you've been repairing radios, maybe you've gained a knowledge of circuits by working on test equipment. It makes no difference either way if you have the 'know how' of circuits write us about the opportunities we have to offer!

WOMEN!

We have a number of fine young women engineers with us now. We need more. If you have a degree in Electrical Engineering, Physics, Chemistry or Mathematics and are seeking career opportunities, investigate.

Phone or Write

DR. L. GRANT HECTOR

Director of Engineering

NATIONAL UNION RADIO CORPORATION RESEARCH LABORATORIES

Plane St. at Raymond Blvd.

Newark 2, New Jersey

WMC RULES OBSERVED

WANTED

RADIO LICENSED AMATEURS

thoroughly familiar with all types of parts, tubes, meters, test equipment, receivers, transmitters, etc. Permanent position; excellent salary; splendid opportunity for some one residing in metropolitan New York area.

SUN RADIO & ELECTRONICS CO.

212 Fulton Street

New York 7, N. Y.

ELECTRICAL and RADIO ENGINEERS RADIO TECHNICIANS

FOR DESIGN, DEVELOPMENT
AND PRODUCTION WORK
POST WAR OPPORTUNITY

ALLEN D. CARDWELL MFG. CORP.

81 Prospect St.

Brooklyn

Wanted ENGINEERS

Radio

*Electrical

Electronic

*Mechanical

Metallurgical

*Factory Planning

Materials Handling

Manufacturing Planning

Work in connection with the manufacture of a wide variety of new and advanced types of communications equipment and special electronic products.

Apply (or write), giving full qualifications, to:

R.L.D., EMPLOYMENT DEPT.

Western Electric Co.

100 CENTRAL AV., KEARNY, N. J.

*Also: C.A.L.

Locust St., Haverhill, Mass.

Applicants must comply with WMC regulations

RADIO RESEARCH Development (Post-War Opportunity)

Expanding national organization has 3 openings on its Research-Development Field Staff. These positions entail some travel with full expenses and allowances paid by the company. Knowledge of radio set construction or definite mechanical ability essential. The positions are permanent and offer an exceptionally fine post-war future. Starting salary \$172.50-\$200.00 per month depending upon ability. Periodic increases based on merit. If you are interested in joining an expanding and progressive company, please give us in confidence full details about yourself for a personal interview.

**BOX 115, RADIO-CRAFT
25 West Broadway
New York 7, N. Y.**

ENGINEERS

Are You Concerned With YOUR POST WAR FUTURE ?

The Federal Telephone & Radio Corporation, the manufacturing unit of the International Telephone & Telegraph Corporation with its multiple business activities extending to all parts of the civilized world, will accept applications from experienced men for immediate employment with almost limitless post war possibilities. These positions should interest those with an eye to the future and whose interest lies in forging ahead with this internationally known organization whose expansion plans for post war are of great magnitude covering all types of radio & telephone communications. Advancement as rapid as ability warrants. Majority of positions are located in the New York area!

We need the following personnel! Men with long experience or recent graduates considered.

- ENGINEERS
 - ELECTRONICS
 - ELECTRICAL
 - RADIO
 - MECHANICAL
 - CHEMICAL
 - TRANSFORMER DESIGN
- SALES AND APPLICATION ENGINEERS
 - PHYSICISTS
 - DESIGNERS
 - DRAFTSMEN
 - TOOL DESIGNERS
 - TECHNICAL WRITERS

Look Ahead With Federal!

If inconvenient to apply in person, write letter in full, detailing about yourself, education, experience, age, etc., to Personnel Manager.

FEDERAL TELEPHONE & RADIO CORP.

39 Central Avenue

EAST NEWARK

NEW JERSEY

FUNGUS (Continued from page 208)

grew and expanded till consumption was ended, then rapidly shrank, exposing the inedible parts. The damage caused was definite, destructive and would interfere seriously with operating efficiency of the equipment involved within a very short time.

Photograph No. 3 is a closeup of the tropical chamber. To the lower left center are some of the equipment and parts being tested. In the immediate foreground are two Motorola Handie Talkies treated with fungicide. Other parts and materials are seen undergoing the test. Some are being attacked by fungi and some are not.

When sufficient tests to warrant conclusions had been made, specifications were set up by the Signal Corps and by Motorola engineers to govern the selection of materials and parts to be used in producing radioelectronic equipment. Detailed in-

structions were provided as to the type and amount of fungicide to be used and the methods of application to be followed. As a result of the tests conducted, radiotelephone units which previously presented operational difficulties within a day or two after tropical exposure, are now delivering the goods in every tropical front where our soldiers are fighting.

Two-way radio messages are coming through from and to the front lines and command posts, assuring our fighting forces that the home front is backing them to the limit with reliable, fool-proof equipment, usable on every battlefield. The Signal Corps, United States Army, the Galvin Manufacturing Corporation and all other electronic manufacturers thus once again prove that the American way of life also means that the best and always and ever the best will be provided for our boys in the service.

LACK OF STANDARDS COSTS MILLIONS

VARIATIONS in electric and mechanical standards have already added \$100,000,000 to the war's cost and have caused incalculable delay in production and repair. This information was revealed last month by William L. Batt of the War Production Board to a joint meeting of the American Society of Mechanical Engineers, the American Standards Association and the Society of Automotive Engineers.

Differences in almost identical equipment and even different specifications and type numbers on identical vacuum tubes have caused difficulties in different branches of

the American armed forces, but these have mostly been ironed out already. Confusion in schematic drawings has been ended with the adoption of a coordinated system, and the Army and Navy now use the same type numbers for tubes and many other electronic parts.

A vast gulf still remains between American and European apparatus, greater even in mechanical than in electrical apparatus. This Mr. Batt hopes to bridge in places by means of coordinated standards similar to the compromises already adopted between different groups in the United States.

Transmitting or Receiving

RADIO STATION TECHNICIANS

MEN AND WOMEN

for Point-to-Point International Radio-communications Stations in the United States.

Applicants must possess at least Second Class Commercial Radiotelegraph Operator's License.

Essential workers need release statement.

Apply weekdays except Saturdays between 10 am and 3 pm

or write

PERSONNEL DEPARTMENT

R.C.A. COMMUNICATIONS, Inc.

64 BROAD STREET
NEW YORK 4, N. Y.

FIELD SERVICE ENGINEERS

For Domestic and Foreign Service

Must possess good knowledge of Radio

Essential workers need release.

HAZELTINE CORPORATION

58-25 Little Neck Parkway
Little Neck, Long Island

ENGINEERS DESIGNERS

ELECTRICAL, MECHANICAL, RADIO, ACOUSTICAL

For Research and Development Laboratory of large company fully engaged in war work manufacturing aircraft accessories. Activity includes electronic control equipment, continuous recorders, special radio devices, etc.

Excellent post-war opportunities. Laboratory located in central Manhattan. All replies strictly confidential.

Write or phone our personnel director

LEAR, INCORPORATED

1860 Broadway, New York, N. Y. Tel. Circle 6-5665

India's new Broadcasting House at Delhi houses the world's champion polyglot station. Regular broadcasts are carried on in the English, Hindustani, Bengali, Tamil, Telugu, Marathi, Gujarati and Pushtu.

New Direct-Coupled FM - AM AMPLIFIER MANUAL

By **A. C. SHANEY**
Chief Engineer, Amplifier Co. of America



**For the Layman, Serviceman
Recordist and Engineer**

Regardless of whether you are interested in the finest type of phonograph reproduction, high fidelity recording, sound-on-film applications, FM or AM programs, you will find invaluable information in this practical handbook. Written by the leading exponent of direct-coupled amplifiers who has spent more than 10 years improving and perfecting the famous Loftin-White circuit.

Explains the theory and practical application of:

- Variable Speed Non-Overloading Push-Pull Expansion
- Non-Frequency Discriminating Scratch Suppression
- Push-Pull Balanced Direct-Coupled Amplification
- Push-Pull High-Frequency Equalization
- Push-Pull Low-Frequency Equalization
- Push-Pull Volume Compression
- Automatic Volume Limitation
- Automatic Volume Control
- Calibrated V. U. Indicator
- Audio Spectrum Control
- Remote Control

If you are interested in the latest audio developments, you can't afford to be without this complete compilation of authentic articles on Direct-Coupled Amplifiers. 32 pages 8 1/2" x 11". Over 100 diagrams and illustrations.

Priced to Cover Cost of Printing and Mailing **25c**
Send U. S. Stamps or Coin

AMPLIFIER CO. of AMERICA
396 BROADWAY NEW YORK, N. Y.

12 WEEKS SHOP TRAINING TRAIN FOR YOUR PLACE IN ELECTRICITY

All Finance Your Training

At Coyne you "Learn by Doing" on real machinery and equipment. Trained Electrical men needed now. Electricity offers you opportunities for the best jobs today, and a real peace-time future. Don't let the opportunities of peace-time catch you unprepared. Get your electrical training now.

EARN WHILE LEARNING, JOB HELP AFTER GRADUATION

The place to get your electrical training is at Coyne. We have been training men and young men for 45 years — by the famous "Learn by Doing" method in the great Chicago shops of Coyne. Many do part time work to help out with expenses. Free lifetime employment service when you graduate.

Right now I'm including extra training in Industrial Electronics at no extra cost. Send coupon now for Free Book and details. No obligation; no salesman will call. I want to send you the facts and let you decide. Mail coupon today.

H. C. LEWIS, President
COYNE ELECTRICAL SCHOOL
500 S. Paulina St., Dept. 15-78, Chicago, 12, Ill.
Send me your Free Book and tell me about your plans to help me.

Name

Address

City Zone..... State.....

**EXTRA
4 WEEKS
COURSE IN
INDUSTRIAL
ELECTRONICS
INCLUDED!**



We have facilities for men with physical disabilities. If you have a physical disability of any kind write me when you send the coupon.

TECHNOTES

.... 12A8 REPLACEMENTS

Because of the shortage of such tubes as the 12A8—GT, many otherwise good sets are piling up on servicemen's shelves or have to be returned to the customer unusable for the duration. The following hints may help get them back into service.

12A8-GT tubes may be replaced with 7A8 loctals. Cut the base of the bad 12A8-GT with a hack-saw leaving prongs intact. Break out the key or center part of the base, enlarging enough to pass the key of the 7A8 through. A notch is now filed into the hole at the proper spot, making a snug adapter for the new tube, the loctal prongs fitting into the hollow prongs of the base.

Connections are made as follows: 2 to 1, 3 to 2, 4 to 5, 5 to 4, 6 to 3, 7 to 8, 8 to 7, grim cap to 6. A 60-ohm, 2-watt resistor is wired in series with either prong 1 or 8.

E. J. SCHMIDT,
St. Catharines, Ontario.

(The above method was also described by Mike Musachio, General Delivery, Jasper, Tex., using 7A8 for 12SA7. Connections are: 2 to 1, 3 to 2, 4 to 5, 5 to 4, 6 to 7, 7 to 8, 8 to 6. Both methods are technically correct.—Editor)

.... TROUBLES WITH 1R5

The 1R5 has often been used for the unavailable 1A7, but some of the service shops say they can't cure oscillation, especially on the 3-way portables and rebuilt 1.4-volt battery sets. The 1R5 oscillator spills over. A lot of the 1A7 oscillator grid circuits use a grid resistor as high as 300,000 ohms. This will have to be changed to 50,000 ohms. This has always cured our troubles so far.

For one who has never tried the 1R5 substitute, the screen-grid is the oscillator anode and the 1A7 screen circuit is not used.

W. G. ESLICK,
Wichita, Kans.

.... SILVERTONE 101.504 BATTERY

This set would take a minute to start playing then reception was choppy and choked, especially on high notes. Rotation of dial would again cut off reception for a minute.

Changing from bias cells to automatic bias restored the set to normal.

LELAND GARRISON,
Drakesville, Iowa.

USED RADIOS

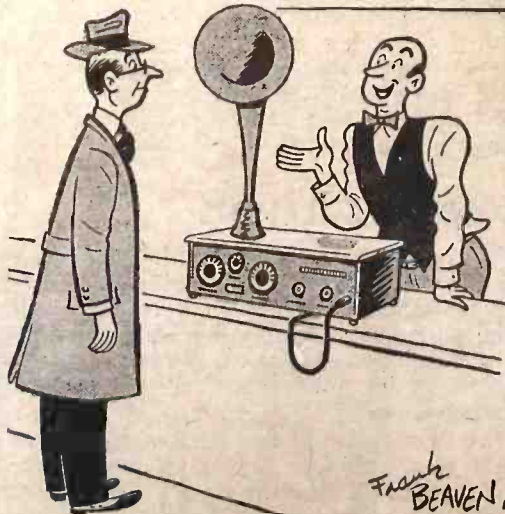

Suggested by: E. R. Loving, Weston, Mo.

"Here's one I can let you have for a reasonably outrageous price."

.... 25Z5 SUBSTITUTE

While searching (fruitlessly) for a replacement 25Z5, I noted that 25A7G's were relatively plentiful. Since this tube has the same filament voltage and current rating, it should be possible to use it as a substitute for the 25Z5 or 25Z6 in sets not drawing more than its maximum plate current (75 Ma.).

An adapter was made from a defunct 25Z5 and the 25A7 hooked in. As I thought I might get some extra power from the pentode section, I attached the rectifier cathode and plate to one set of cathode and plate terminals of the 25Z5 and the pentode cathode and plate to the other, obtaining a higher output than that available from the rectifier section alone.

AARON ORENSTEIN,
Brooklyn, N. Y.

(The two plate and two cathode terminals are usually wired in parallel in A.C.-D.C. receivers, in which case the circuit shown would work well. In some sets the two cathodes feed two separate circuits. An examination of such receivers should be made to insure that the pentode section is not required to supply currents greater than the 25 Ma. for which it is rated.—Editor)

.... OPEN AUDIO PRIMARY

Here is a war-time service tip that made it possible for me to help one family receive programs on a radio which had been out of order for over a year.

The radio was an old Philco Model 87. The primary of the input transformer leading to the 45 push-pull tubes was open. So I connected a 250,000 ohm, 1 watt carbon resistor across the open primary and connected a .005 mfd., 400 volt, condenser from the plate of the preceding 27 tube to one side of the secondary of the push-pull input transformer. The set played with good volume and excellent tone.

B. DEUTSCHMAN,
Runnemede, N. J.

.... WEAK DISTANCE RECEPTION

Quite often radio sets display sufficient volume on locals but are very weak on distance. I find that this is caused many times by a poor or loose connection in the secondary of the antenna coil leading to the grid of the following tube.

JERRY ALBERT,
Orlando, Fla.

.... SPEAKER CENTERING

It is sometimes found very difficult to center speaker cones on the midget type radios which have no centering devices. Because of their scarcity, the present cones must be made to work. By rubbing, the cone may be stretched so that it fits without scraping. The finger is simply rubbed along the inside, at a spot determined by touching the cone at various places while the set is playing. The place at which a touch produces better tone is the correct spot.

Another method is to place a snug fitting shim between cone and core. Then soak the paper cone with cigaret lighter fluid, carbon tet or other fast drying chemical that doesn't harm the cone. After drying, remove shim. Soaking removes any stress that would cause the cone to be off center.

WILLIAM H. DICK,
Madison, Wisc.

FOR SALE HARD-TO-GET ITEMS

All items are brand new, except where indicated. ALL are in PERFECT WORKING ORDER. In many cases, the parts alone total more than the price we are asking. Satisfaction guaranteed or your money back. ORDER FROM THIS PAGE. Use our convenient coupon. Include sufficient extra remittance for parcel post charges, otherwise order is sent express collect. Any excess will be refunded. All C.O.D. shipments require 20% deposit. No C.O.D. shipments on orders for less than \$5.00. If full remittance accompanies order deduct 2% discount. Send money order, certified check, or new U. S. stamps. No C. O. D.'s to foreign countries.

THE MAGIC ELECTRIC WELDER



Here is one of the most compact, practical welders we have ever seen. Anyone can use it for shop, farm and home repairs. **WELDS, BRAZES, SOLDERS, CUTS ALL METALS. ANYONE CAN OPERATE IT.** Repairs steel, cast iron, aluminum, brass, copper, bronze, etc. Complete with power unit, flame and metallic arc attachments. (Really two welders in one). Carbons, fluxes, rods, mask included. Just plug it in any electric outlet, 110 volts AC or DC. For hobbyist or professional.

GET IN ON THE GREAT WELDING BOOM. This fine set quickly teaches you welding. Low cost to operate—about 5c an hour. COMPLETE SAFETY is assured. No fumes with this outfit. SET COMES COMPLETE—nothing else to buy. Used by the U. S. Navy, American Tel. & Teleg. Co., Eastman Kodak Co., Bell Laboratories, etc. BRAND NEW OUTFIT. Guaranteed for one year. Simple instructions with each set.

ITEM NO. 158
YOUR PRICE \$19.95

WESTERN ELECTRIC BREAST MIKE

This is a fine light-weight aircraft carbon microphone. It weighs only 1 lb.

Mike comes with breastplate mounting and has 2-way swiveling adjustment so that it can be adjusted to any desired position. There are 2 woven straps; one goes around neck, the other around chest. Straps can be snapped on and off quickly by an ingenious arrangement.

This excellent mike can be adapted for home broadcasting or private communication systems. By dismounting breastplate, it can be used as desk mike.

Comes complete with 6-foot cord and hard rubber plug. Finished in shirazite plate, non-rustable.

THIS IS A BRAND NEW MIKE. IT HAS NEVER BEEN SOLD AT SUCH A LOW PRICE BEFORE. ORIGINAL LIST PRICE \$15.00. Shipping weight, 2 lbs.

ITEM NO. 152
YOUR PRICE \$2.55

POWERFUL ALL-PURPOSE INDUCTION MOTOR

IDEAL FOR EXPERIMENTERS—101 USES



Sturdily constructed to precision standards, this self-starting shaded pole A.C. induction motor is powerful enough for a number of uses. Some of these are: Automatic Timing Devices, Current Interrupters, Electric Fans, Electric Chimes, Window Displays, Photocell Control Devices, Electric Vibrators, Small Grinders, Buffers and Polishers, Miniature Pumps, Mechanical Models, Sirens, and other applications.

Consumes about 15 watts of power and has a speed of 3,000 r.p.m. When geared down, this sturdy unit will constantly operate an 18-inch turntable loaded

with 200 lbs. dead weight—THAT'S POWER! Dimensions 3" high by 2" wide by 1 3/4" deep; has 4 convenient mounting studs; shaft is 3/8" long by 3/16" diameter, and runs in self-aligning oil-retaining bearings. Destined for 110-20 volts, 50-60 cycles, A.C. only. Shp. Wt. 1 lb.

ITEM NO. 147
YOUR PRICE \$2.25

LIMITED QUANTITIES! PROMPT SHIPMENTS!

It's Easy to order—Clip Coupon—Order from This Page—No Catalog Sent.

MAIL TODAY—NOW!

HUDSON SPECIALTIES CO.

40 West Broadway, Dept. RC-1-45, New York 7, N. Y.

I have circled below the number of the items I'm ordering. My full remittance of \$..... (include shipping charges) is enclosed. (NO C.O.D. ORDERS UNLESS ACCOMPANIED WITH A DEPOSIT.)

OR my deposit of \$..... is enclosed (20% required) ship order C.O.D. for balance. NO C.O.D. ORDER FOR LESS THAN \$5.00. (New U. S. stamps, check or money order accepted.)

Circle item No. wanted 147 152 158

Name

Address
Please Print Clearly

City State

Send remittance by check, stamps or money order; register letter if you send cash or stamps.

STATION RIDING

(Continued from page 216)

touching, insulate the pipes from each other or bond them together so that a better electrical contact is established. On buildings with metal roofs, it is suggested that the individual metal plates be bonded together and then grounded. Watch the antenna and lead in, making sure they do not touch near-by metal objects. In the case of rusted guy wires, break them up with strain insulators or clean and solder the splices. Metal clothes lines terminated at rusty hooks or pulleys should be checked.

In cases where it is not practicable or economical to cure the station riding at its source, or where the source is too difficult to locate, other measures may be tried. In receivers using a loop antenna where only one interfering signal is present, a loop type wave trap should be tried. This consists of an extra loop antenna strapped to the loop antenna in the receiver, as shown in Fig. 5. This extra loop is shunted by a trimmer condenser of sufficient capacity to tune it to the frequency of the interfering signal. Adjust the trimmer condenser until the attenuation of the interfering signal is maximum.

For receivers designed for use with an external antenna and ground, wave traps of the resonant or anti-resonant types may be tried. A combination of both types may be used as shown in Fig. 6. Adjust both wave traps for maximum attenuation of the interfering signal. Where interference is general from stations at the high frequency end of the broadcast band, the interference may be reduced by shunting the antenna and ground connections with a small mica condenser of approximately 50 to 100 micro-microfarads capacity. If the receiver has short-wave bands and the listener uses these bands, an R.F. choke of approximately 2.5 millihenries should be used in series with the condenser (Fig. 7). The reactance of the choke will be so high on the short wave bands as to nullify the effect of the condenser, but still make it effective on the broadcast band.

A good ground connection often helps in reducing radio interference. (The writer has seen a nail driven into a flower pot used as a ground—this is *not* a good ground connection.) Use of a properly designed line filter aids materially, especially with A.C.-D.C. type receivers. Loop antenna type receivers often perform better when used with a vertical rod type outdoor antenna. See Fig. 8 on suggestions as to methods of connecting an outdoor antenna to loop antenna receivers. The one-turn loop coupled to the receiver's loop antenna works quite effectively, especially with receivers using two- or three-turn low impedance loop antennae.

When image interference is strong, a sensitivity control as shown in Fig. 9 will often make the receiver more usable. This control may be installed on the rear of the receiver chassis and adjusted to a position where reception is most satisfactory, then left that way.

The writer has wandered from the original discussion of station riding to other types of radio interference as their cures are closely related. There is no definite cure-all for all cases of station riding, and some cases will give that radio technician quite a tussle before the answer is found. It is hoped that some of the suggestions presented here will be of benefit in the quest for better radio reception.

IMMEDIATE DELIVERY RADIO PARTS

Kit No. 1—100 1/4-Watt carbon resistors—color coded \$1.95

Kit No. 2—100 carbon resistors—25 1-Watt, 75 1/2-Watt ... \$2.94

Kit No. 3—100 1/3-Watt insulated resistors—color coded ... \$2.94

Kit No. 4—100 assorted by-pass and buffer condensers. List price over \$20.00 \$5.83

Kit No. 5—25 popular assorted by-pass condensers \$1.59

Hook-up and Push-back Wire—89c per 100 ft. 10 assorted 100-ft. rolls only \$7.80

Kit No. 6—20 assorted trimmer and padder condensers96

Kit No. 7—50 assorted terminal lugs—2 to 6 lugs96

Kit No. 8—50 assorted rubber grommets69

Write for our latest bulletin listing hundreds of necessary items for the radio and soundman.

LIFETIME SOUND EQUIPMENT CO.
P.O. BOX 834 TOLEDO 1 OHIO, U.S.A.

new!

DE LUXE BINDER



Preserves Your
RADIO-CRAFT
BACK ISSUES
Permanently



only
\$1.50

HOLDS
12 ISSUES

PROTECT your back issues in this new beautiful De Luxe Binder, tailor-made to fit 12 issues of RADIO-CRAFT.

Well-constructed, finished in simulated Morocco leather, rich russet brown with gold embossed lettering and design on front and back. Size 9" x 12 1/2" with 1 1/4" back.

No punching of magazines necessary. Just slip your RADIO-CRAFT magazines through a metal strap built into the binder. In a jiffy they are in place and everlastingly protected.

Start now to keep your magazines clean, fresh-looking for instant reference—instead of lying around helterskelter, torn, dog-eared and soiled . . . very likely lost. This De Luxe binder is attractive enough to dress up your living room library shelves.

5-DAY FREE TRIAL

The De Luxe Binder is guaranteed to more than satisfy. If not, return within 5 days and your money will be cheerfully refunded. Sent postpaid in U.S. on receipt of \$1.50. (Canadian and Foreign \$1.75.)

RADIO-CRAFT

25 West Broadway, New York, 7, N. Y.

SPEED UP REPAIRS WITH THESE G-C AIDS!



FREE
STEEL
CABINET

G-C DIAL BELT KITS

Exact replacement woven fabric belts. Easy* install—no stretching—no adjustments—a perfect fit every time. Kits come with 25, 50, 100, 200 or 300 belts.



G-C AUTOMATIC WIRE STRIPPER

Strips insulation from all types of wire. Does the job instantly, easily, perfectly. An ideal tool for radio men, electricians and sound men.



G-C CONTACT SERVICE KIT

Contains special contact cleaner and corrosion resistant lubricant. You can clean noisy controls nine times out of ten without dismantling chassis or control unit. Pays for itself over and over.

Order From Your Radio Parts Jobber
ALWAYS ASK FOR G-C PRODUCTS



GENERAL CEMENT MFG. CO.

ROCKFORD, ILLINOIS

Of Course,
You Can't Be There—But—

NO, you can't be there at the dressing station to give him a mother's care. All you can do is be thankful that the Army and the Red Cross take such good care of our boys. But you can help see to it that such precious supplies as blood plasma, food and ammunition, reach the front in prime condition—ready to do their job.



For every one of the 700,000 items shipped to our troops is protected against weather and dirt by paper and paperboard. That's why your government asks you to use less paper, and save every scrap you can. Remember that every time you are tempted to waste paper or destroy it.

Remember
**PAPER IS
WAR POWER**



Use Less Paper—Save All Wastepaper

This advertisement prepared by the War Advertising Council in cooperation with the W.P.B., the O.W.I. and published by this magazine, which has joined with the other magazines of the country to save more than 450,000,000 pounds of paper.

OPPORTUNITY AD-LETS

Advertisements in this section cost 20 cents a word for each insertion. Name, address and initials must be included at the above rate. Cash should accompany all classified advertisements unless placed by an accredited advertising agency. No advertisement for less than ten words accepted. Ten percent discount six issues, twenty percent for twelve issues. Objectionable or misleading advertisements not accepted. Advertisements for February, 1945, issue must reach us not later than January 28, 1945.

Radio-Craft • 25 W. B'way • New York 7, N. Y.

CORRESPONDENCE COURSES AND SELF-INSTRUCTION books, slightly used. Sold, Rented, Exchanged. All subjects. Satisfaction guaranteed. Cash paid for used courses. Complete information and 92-page illustrated bargain catalog free. Write—NELSON COMPANY, Dept. 2-39, Chicago 4.

"100,000 POST-WAR JOBS ABROAD"—SOUTH AMERICA, Asia, Africa. How, When and Where to Apply. 15,000-word copyrighted forecast—\$1.00. Return for refund in 7 days if not satisfied. Pacific Industrial Research Bureau, 202-X Studio Building, Portland 5, Oregon.

PREPARE NOW FOR TREMENDOUS OPPORTUNITIES in new fields of radio after the war. Training for Federal Licenses. Write for particulars. American Radio Institute, 44 East 23rd Street, New York 10, N. Y.

METERS, INSTRUMENTS, VACUUM-TUBE VOLTMETERS repaired and recalibrated. Immediate service and guaranteed workmanship. The Moring Co., 1414 Main St., Lynnfield Centre, Mass.

SCIENCE ENTHUSIASTS IN ALL FIELDS NOW HAVE a printed monthly written by them FOR them. 15c brings latest issue. Amateur Scientists' Magazine, 45 North Evergreen, Memphis, Tenn.

WANT FINANCIAL INDEPENDENCE? I'VE HELPED hundreds. Dr. Tibott, 25 RC 185 Godfrey, Phila. 20.

USED CORRESPONDENCE COURSES AND TECHNICAL Books Bought, Sold, Rented. Catalog Free. Educational Exchange, Henager, Alabama.

SAL-AMMONIAC TINNING BLOCKS 50 AND 75 cents. Dealers wanted. Opportune Products, Box 8, Normandy 21, Mo.

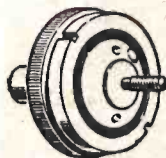

"WONDER" ELECTRIC BUTTON

Most interesting electrical apparatus ever discovered. Make your own Telephone-Amplifier rooms. Perform hundreds of fascinating experiments. So tiny it can be concealed in dozens of places. Send \$1 now for button and free 5,000 word instruction booklet with 50 illustrated experiments. **SPECIAL OFFER** 6 buttons and booklets sent postpaid for \$5. Write now to

BUCK MFG. COMPANY North Aurora, Illinois

• **Ted McElroy**

World's Largest Manufacturer of
Wireless Telegraphic Apparatus

COMPLETE CENTRAL OFFICE EQUIPMENT

McElroy Manufacturing Corp.

82 Brookline Avenue • Boston, Massachusetts

UNDERSEA TELEVISION

IT is now practical to explore and recover objects from the bottom of the sea using the medium of television. This device was evolved by Walter B. Lang of Washington, D. C., and is available for use by or for the U. S. Government without payment of royalty of any kind. A complete television transmitter is lowered into the water together with floodlighting and means are provided for recovery of objects found.

The apparatus may be lowered from a boat on the surface. Two connecting lines act as a supporting cable and a protected electrical cable which houses all necessary electrical wires are employed.

In Fig. 1 a closeup of this unusual device is shown in detail. The power line operates a reversible motor M, direction of rotation being under the control of the operator. The motor rotates a threaded rod S through a coupling C. The effect is to rock the links and the arms transfer the motion to the lower jaws. Full lines show the jaws open ready to receive an object, while the dotted lines show the position of the parts when the jaws are tightly shut, enclosing the sunken object.

The television transmitter is housed within the jaws with suitable lighting so that the area directly below it may be completely examined. The sea floor may be inspected conveniently on a television receiver located in the boat above. Television signals are transmitted through wires incorporated in the protected cable, though the inventor suggests that for reasonable depths conventional (radio) means of television transmission may be utilized.

There is no theoretical depth limit beyond which this device will not operate nor is it limited by human endurance or hazard to personnel.—I. Q.

FIG. 1

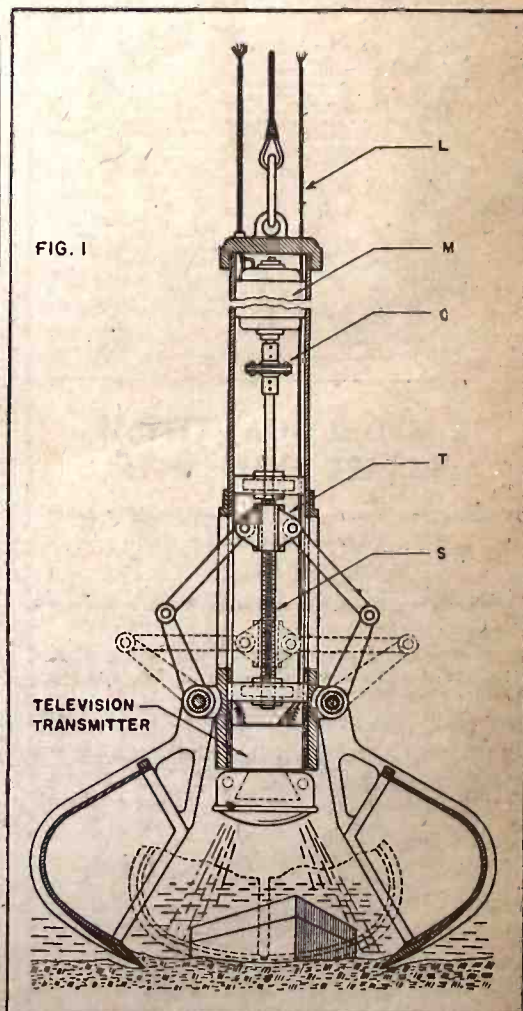

DOTS AND DASHES

By H. E. LEIGH, SR.

AFTER nearly three years of war, our neighborhood radio club has dwindled to three members. The others have been lost to active service or important war jobs in distant cities. We survivors are also doing our utmost to finish the business on hand, but find time to get together twice a week to give the new WERS boys and girls some code practice, discuss magazine articles on post-war developments and construct gadgets from the old parts that used to be our amateur stations.

Al, the local radioman, was one of the newcomers who had joined just for the code practice. He had his mind on the Signal Corps, and Joe and I promised to make a real operator out of him. He knew his stuff and we were obliged to him for plenty of dope on the theoretical angles.

There was just one thing wrong with Al. His timing was lousy. We thought he would outgrow it but as his speed increased he got worse. Joe and I decided that his spacing would have to be called definitely to his attention.

"Your dashes are not long enough, Al," I spoke up. "When you speed up they seem to get shorter."

"I tried to make them longer than the dots," Al replied. "I don't understand why you can't tell the difference. How much longer should they be?"

Joe broke in. "They should be twice as long as the dots. Then you won't have any trouble being understood."

"Twice?" I asked. "You mean three times. A dash should be equal to three dots. That's the rule."

"Oh, no!" said Joe. "I've been an operator since the days of the old Dodge Telegraph Instructor, and I know. The dash is twice as long as the dot. The letter 'L' was three times as long and the cipher four times as long. We dropped them when we went to wireless, but the length of a dash is still twice that of a dot." Joe was supremely self-confident.

"Listen, you fellows!" complained Al. "Make up your minds so I can get going." But Joe and I were too involved to pay any attention to him by now. I was pretty sure of myself, too.

"Don't tell me anything about code timing. The Candler system says the dash is three dots in length. How about spacing between letters, Joe?"

"Well, that depends on how fast you're sending. Should be about three dots between letters and five dots between words. At least that's what I think. The important thing is that the fellow doing the copying doesn't run the words together."

"Doesn't the ARRL say that space between words should be seven dots?" I asked him.

Very impatiently Al came in again. "What's going on here, a code session or a debate? I don't understand how you fellows can copy everything that's thrown at you if you have no idea of your own timing!"

There was nothing to do but ask someone and find out. But it wasn't going to be that simple. We got a fairly unified opinion, but when we tried to get at the authority behind it, not one operator had any idea. It was just the way he had been taught. Where and when he had been taught decided his opinion.

I thought of the radio inspector and called him up. Even he wasn't sure, but would look it up. Sure enough, next morning I had a letter from him with the following **CORRECT SPACING** of the International Morse Code, taken from the Telegraph Regulations annexed to the International Telecommunications Convention (Cairo) under the heading "Morse Code Signals."

- 1—A dash is equal to three dots.
- 2—Spacing between characters equals one dot.
- 3—Spacing between letters equals three dots.
- 4—Spacing between words equals five dots.
- 5—When punching is used on a Wheat-

stone apparatus, the spacing between two letters is equal to one "blank" and the spacing between two words is equal to three "blanks."

We held a special session that evening and had Al send to us at different speeds. Here is what we found. His dashes were about twice the length of the dots at low speeds and as he speeded up they became smaller. Spacing between letters was normal at low speeds but almost disappeared at maximum!

Well, the next few sessions worked wonders. Let me tell you, inside of three weeks Al was correcting *our* timing! And did we like it! His speed worked up to 20 per and you would swear he was an automatic tape machine in person. Of course Joe and I took credit for being excellent code teachers, wherever we got the chance!

It was only about a month later that Al received a most important call.

Oh, yes, we heard from him the other day. The card came from the direction of the setting sun. We pieced together that he was holding down an important communications post. He—and many others—were helping to make the Japs "so sorry."

Any electronic heater installed in Great Britain must be approved as non-interfering by the Post Office (British radio licensing authority). All high-powered equipment must be operated inside shields approved and constructed in accordance with the Post Office's "Engineering Instructions, Radio Interference," which requires that certain types of apparatus be operated in screened rooms or "cubicles." The problem of interference from industrial devices is thus being solved by the British before it arises.—*Wireless World*, July, 1944

ELECTRICITY

● for Radio and
Electronic Applications

ONAN ELECTRIC GENERATING PLANTS supply reliable, economical electric service for electronics applications as well as for scores of general uses.

Driven by Onan-built, 4-cycle gasoline engines, these power units are of single-unit, compact design and sturdy construction. Suitable for mobile, stationary or emergency service.

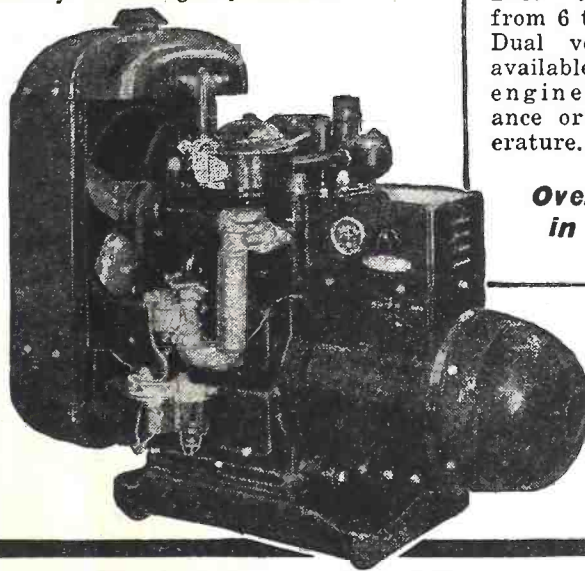

Model Shown is from W2C series, 2 and 3-KW, 60-cycle, 115 volt; powered by water-cooled, 2-cylinder engine.

D. W. ONAN & SONS 2411 Royalston Ave.,
Minneapolis 5, Minn.



Models range from 350 to 35,000 watts. A.C. types from 115 to 660 volts; 50, 60, 180 cycles, single or three-phase; 400, 500, and 800 cycle, single phase; also special frequencies.

D.C. types range from 6 to 4000 volts. Dual voltage types available. Write for engineering assistance or detailed literature.

**Over 200,000
in service**

DIATHERMY BANDS NEEDED

DIATHERMY urged its claims for continuance of bands already granted to it, at the FCC hearings on allocations last month. Dr. Warren F. Morrill, for the American Hospital Association; A. W. Mathes of the H. G. Fisher Company, and Dr. Lee De Forest of the De Forest Laboratories, on behalf of the Physical Therapy Group of the American Surgical Trade Association, supported the joint request.

An estimated 50,000 short wave diathermy machines are now operated by civilian hospitals in the vicinity of those parts of the spectrum referred to in a general way as the 40, 27 and 13 megacycle bands. Allocation of the small portion of the spectrum desired for this service, of benefit to hundreds of thousands of ill and injured persons was presented as "a not unreasonable request" by the applicants.

Dr. De Forest, pioneer in radio, and manufacturer for eleven years of medical diathermy apparatus, discussed the value and importance of the three bands for the special purposes used and urged, failing their allocation, the assignment of one broad frequency band in the neighborhood of 27 megacycles. He said that such a single clear channel, having a tolerance of 7 per cent of the wave length, would be the best alternative, though "not so good" as continued use of the only three bands.

Proof that radar is as much at home in the fields of peace as those of battle was given recently during the planning of a new cathedral in Manchester, England. Radar was brought into play in making tests for the best position for an organ loft.

TECHNICAL BULLETINS

Technical bulletins give reliable information in easy-to-follow form, and save valuable time otherwise spent in laborious reading of numerous books. Every subject is treated briefly and concisely, yet completely. No complicated mathematics, chemistry, electricity, or theory. Each bulletin is written in simple language.

Each Bulletin consists of a set of large sheets, assembled in one packet, size 9 x 14 1/2"; weight 1/4 lb. Numerous illustrations, diagrams, charts to supplement text.

PRICE \$1.00 EACH POSTPAID
ORDER BY NUMBER

- D-111—DESIGNING AND BUILDING TRANSFORMERS
- D-112—DESIGNING ELECTRO-MAGNETS
- D-113—HOW TO DESIGN SOLENOIDS AND PLUNGER MAGNETS
- D-101—USING NICHROME RESISTANCEWIRE
- D-106—REWINDING ELECTRIC MOTORS
- D-144—ALTERNATING CURRENT CONTROLLED WITH EASILY MADE CHOKE COILS
- D-148—DESIGNING AND USING ELECTRIC RELAYS
- D-127—SMALL ELECTRIC LIGHT PLANTS
- D-134—ELECTRICAL EXPERIMENTS WITH SIMPLE MATERIALS
- D-131—MODEL MAKERS & INVENTORS GUIDE TO REMOTE-CONTROL SWITCHING
- D-137—ELECTRICAL METERS EASILY BUILT
- D-136—SMALL A.C. ARC WELDER CONSTRUCTION AND USE

Send Stamps, Cash or Money Order

TECHNIFAX

1917 S. STATE ST. RC-1-45 CHICAGO 16, ILL.

DEPT. RC-1

TECHNIFAX 1917 So. State, Chicago, 16, Ill.

Enclosed find \$..... for which please send me postpaid the following Technical Bulletins:

Nos.

.....

Name

Street and Number

City and State

COL. DAVID SARNOFF, president-on-leave of RCA, was last month awarded the Legion of Merit "for outstanding service." In further recognition of his overseas work, Col. Sarnoff was nominated by President Roosevelt for promotion to the rank of Brigadier-General.

The citation follows:

"For exceptionally meritorious conduct in the performance of outstanding service while serving as Assistant to the Deputy Chief Signal Officer, Supreme Headquarters, Allied Expeditionary Force, from 23 August 1944 to 16 September 1944. Col. Sarnoff was largely responsible for reopening communications in Paris, thus enabling press communications to resume both to the United Kingdom and to the United States. His ingenuity and resourcefulness made it possible to restore cables which had been severed by the enemy, and allowed French radio experts who had not worked for many years during the occupation, to return to their former duties. Col. Sarnoff's outstanding devotion to duty, courage, and great diplomacy in handling French citizens have aided materially in overcoming the great difficulties in attaining this objective."

The Mail Bag

SUCCESSFUL RAZOR-BLADE RECEIVER

Dear Editor:

I have constructed the "fox-hole" receiver as described in the September issue of *Radio-Craft*, using a razor blade and safety pin. Results were fair; volume was rather weak. Stations heard were: WFVA, WLW, WWL, WHAS, WJR, and WJZ. Also, the airports at Washington, D. C., and Pittsburgh, Pa.

I found that crystal headphones gave better results than magnetic headphones. Also, I could increase the volume by connecting

a second antenna to the safety pin.

WHEELER T. THOMPSON,
Fredericksburg, Va.

(If Washington and Pittsburgh stations could both be heard, results might be said to be excellent. Note that volume [and distance] on the fox-hole receiver—as on its brother the crystal set—depend almost entirely on the height and length of the aerial. —Editor)

RADIO-BOMB COVERS AND BRITISH BUSES

Dear Editor:

I have been a reader of your publications since 1927, my favorite being *Radio-Craft*, which is tops with me. There is more dope in one page than in a complete magazine of ours.

Through this war I've had seven addresses and lost all my *Radio-Crafts*. However, with you Americans maybe that won't happen again if we keep our desires united in peace as in war. Through our bad days (and we had some) Mr. Gernsback was there in his editorials assuring us and always pointing out the future.

I must tell you of a funny incident. I was traveling on a bus reading *Radio-Craft* with the Radio Controlled Bomb on the cover when a flying bomb came over. The people on the bus noted your cover and the remarks that followed were unprintable.

So may I say I enjoy your technical notes, test gear construction, especially your repair articles—these have been terrific for one repairing Blitzed sets. Thanks for your great help through this time of trouble and strife—may the sun shine soon.

R. H. CHILDS,
London, England

THIS CANADIAN SERVICEMAN IS LICENSED

Dear Editor:

I beg to differ with Mr. Pilgrim of Aitkin, Minn. I think he is considerably sarcastic and does not get the point of licensing radio technicians.

We here in Alberta, Canada, are licensed and nobody is forced to bring their sets to us. They can still take them to Johnny Jones or Bill Smith if they want, but they have no come-back if the set does not work.

As for beginners, they are issued an apprentice certificate until they have qualified for another class.

The examination was very fair and I

considered it covered radio servicing very well. I hold a 1st Class Radio Technician Certificate myself, and quite a number of people ask to see it before they let me touch their sets.

For the life of me, I cannot see why Mr. Pilgrim or any other opponents of licensing feel that way. They would not consider going to a doctor or a surgeon if they thought he did not hold a certificate from his State Medical Board.

ERNEST SCHUMAN,
Vermilion, Alberta

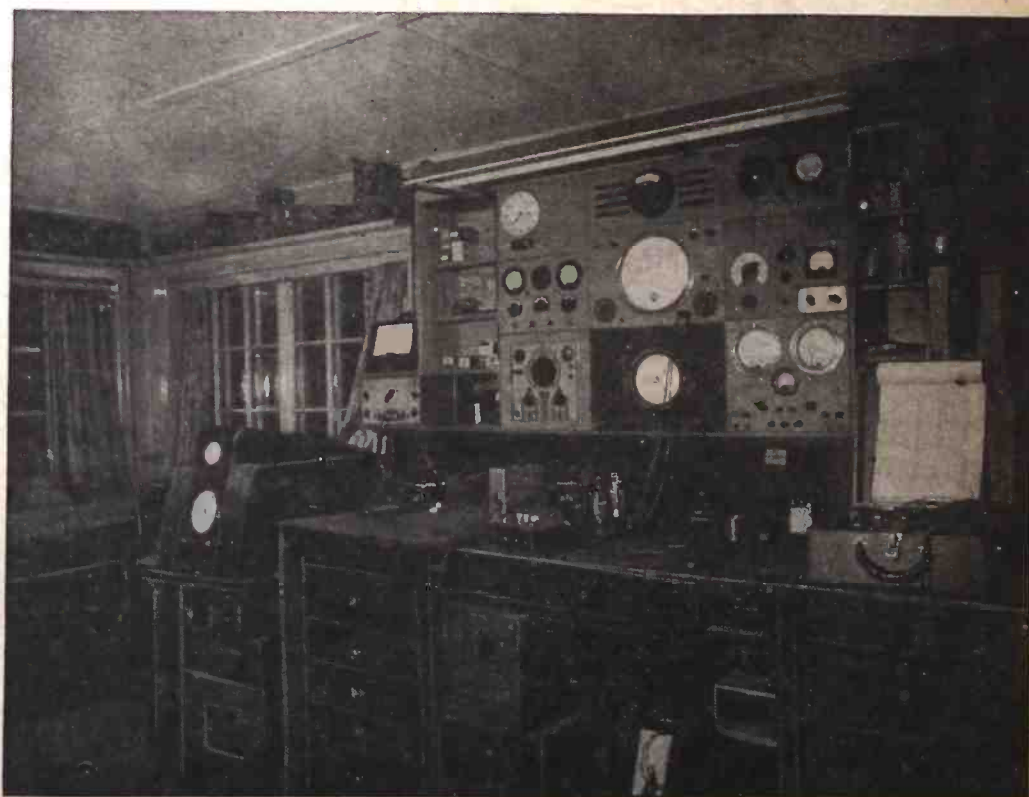

The radio service shop of Mr. Charles Pilgrim, whose views are discussed in the above letter.

RAZOR-BLADE EXPERIMENT

Dear Editor:

As a crystal set experimenter of 22 years standing, I was much interested in your article "Fox-hole Emergency Radios," which are nothing more than an ordinary crystal hookup, with a razor blade used in place of a crystal.

Being the experimenter I am, I naturally took your advice and gave the set a trial. I think the results I got will be of great interest to your readers. Hence, my reason for writing. I tried a Marlin blade first, in the circuit printed. This worked fairly well, though not as loud as a good crystal. Then I tried a Gillette Blue Blade. This gave the weakest possible reception; it was all I could do to bring in a signal. I then tried a Probak blade. It tuned in almost as easily and with as much volume as a fairly loud crystal. Therefore, my advice is to try different blades for loudest possible volume.

But here is another tip; as you said, a light catwhisker contact with various metals will bring in a signal. THAT IS TRUE. I found that I could bring in music with just a catwhisker lightly touching the crystal cup holder—with no crystal in the set at all. I also found that with a light contacting pair of spring clips, a signal could also be brought in; just lay the one spring clip lightly on the other and you can have music—the two clips correspond to CRYSTAL and WHISKER.

In the face of all that, I think no GI should be without a radio, if as you say, wire and headphones, are "somehow" available to 'em.

I thought all this would be of interest to your readers, particularly to the servicemen. Before closing let me express my thanks and appreciation to your staff for a very interesting, readable and fascinating magazine.

JOSEPH D. AMOROSE,
Richmond, Va.

DO DEBATES WASTE PAPER?

Dear Editor:

Why waste paper, when there is such a shortage at the present time, on arguments pro and con about servicing radios by licensed or unlicensed servicemen? I don't agree with either side of the argument. Put the wasted time of writing to some good use by reading a good article or book about radio and electronics, also that wasted space to some good use and have these argumentative people benefit by it.

I know servicemen who argue that same question, and know only enough to read a diagram, instruments and replace duplicate parts, and that is as much as they can do, providing that full data is given in a manual. But stick one of them with a set that he has no print of, or where changes have to be made because of unavailable duplicate parts, and at least 99.99% of them will make a mess of it.

The solution is to forget the arguments and put the wasted time to something worthwhile, by getting their knowledge down pat and putting more time on the electron theory, radio and electronics, to know what it's all about, when they do run up against a sticker. Time will tell whether Mr. Serviceman deserves to get the work from Mr. and Mrs. Public without big splash ads in papers.

I made as good a living at servicing as any average serviceman, but before I claim to be a good serviceman, I'll be 100% sure before I tackle a job. That's one reason I attend college nights to learn electronics and math.

CHAS. MROZKOWSKI,
Erie, Penna.

POST-WAR SERVICING OPPORTUNITIES (Continued from page 203)

electronic education. No superintendent or plant manager would call in anyone to make repairs until assured of his competence. For that reason the post-war radio serviceman must be far better educated along radio and electronic lines than his predecessor ever was.

Mediocre and half-baked technicians will be just out of luck. The post-war serviceman must be an expert in his line because no one but an expert will be trusted to make vital repairs when the entire operation of the plant may depend on his judgment. That is the reason why the post-war serviceman must be able to absorb every bit of radio

and electronic literature he can lay his hands on. He must have all the latest books on the subject. More than that, he must get acquainted with every possible electronic industrial appliance. That means that he has to send to practically every electronic manufacturer in the country for his literature and not only acquaint himself with the various models, but he must know all the ins and outs of each model. This, of course, means a good deal of work and a lot of study. But it can be done by any intelligent man who applies himself to it. There are rich rewards for this type of post-war radio work.

SUBSCRIBE NOW TO-

AND RECEIVE FREE THIS DICTIONARY

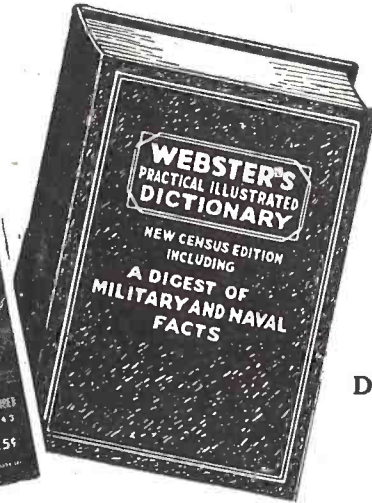
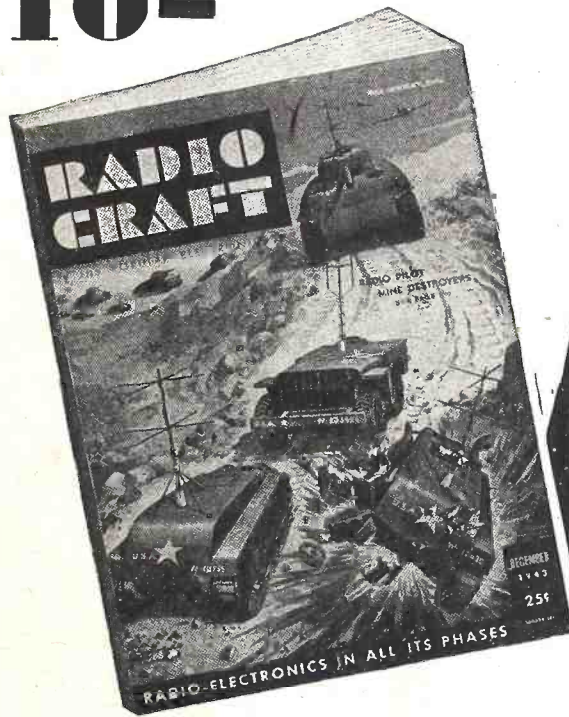

FULL
LIBRARY
SIZE
WEBSTER
DICTIONARY
378
PAGES

FIVE MONTHS \$1.00
TWELVE MONTHS \$2.00

SPECIAL NOTICE TO OUR READERS

Due to wartime curtailment of paper, we are unable to meet the increasing newsstand demand for RADIO-CRAFT. We are therefore making this special introductory offer to our readers.

Assure yourself of getting a copy of RADIO-CRAFT monthly by subscribing now and at the same time co-operate in making this wartime measure effective. Don't delay—send in your order today. Take advantage of our special long-term offer and protect yourself against any possible increase in price by sending \$2.00 for 12 issues.

If you will take advantage NOW of our special subscription offer of five months for \$1.00 or twelve months for \$2.00, we will send you ABSOLUTELY FREE and POSTPAID this 378-page WEBSTER'S PRACTICAL ILLUSTRATED DICTIONARY—useful and instructive to all. This self-pronouncing authoritative dictionary—a brand new work throughout—contains the most up-to-date words now in common use. Over 20,000 definitions in all. In addition, it has the following: List of Largest Cities in the U. S.; List of Principal Cities of the U. S.; List of Principal Cities of Canada; National Parks of the U. S.; Time and Its Variations; Tables of Weights and Measures; Presidents of the U. S.; Synonyms and Antonyms; Dictionary of Commerce and Law; Dictionary of Forms of Address; Military and Naval Information (illustrated); Digest of the Purposes of Current Federal Agencies.

THIS IS A TIME LIMITED OFFER

MAIL COUPON
TODAY FOR A
SUBSCRIPTION
AND DICTIONARY

RADIO-CRAFT
25 WEST BROADWAY
NEW YORK 7, N. Y.

RADIO-CRAFT, DEPT. 1-45
25 WEST BROADWAY, NEW YORK 7, N. Y.

Gentlemen: Enclosed you will find my remittance for which enter my subscription to RADIO-CRAFT Magazine for the period checked below. Send me ABSOLUTELY FREE and POSTPAID the Webster Dictionary.

5 months — \$1.00 12 months — \$2.00
 This is a new order Renewal

NAME
Please Print Clearly

ADDRESS

CITY Postal (if)
Dist. No. (any) STATE.....

Remit by check or money order; register letter if you send cash or unused U. S. Postage Stamps. (Canadian and foreign orders must be accompanied by an International Money Order.) On Canadian orders add 50c for postage; on foreign add 75c for one year.

Complete Plans

For Building Useful and Practical Things at Home. Each issue of Popular Homecraft is crammed with plans for making such beautiful and useful things as: Furniture, Bird Houses, Lamps, Outdoor Garden Furniture, Camping Equipment, etc. Covers lathe work, tools, wood-working, leathercraft, copper. You'll find "how" to make almost everything from the pages of Popular Homecraft. Scores of drawings and photographs make every step simple as A B C. A real "How-To-Do-It" magazine.



Six Months' Trial \$1.00

Send \$1.00 today for trial six months' subscription. Money Back if Not Delighted.

POPULAR HOMECRAFT

937 Palmolive Building Chicago, Ill.

Trial 6 Months \$1.00

\$3.00 FOR YOUR CARTOON IDEAS

RADIO-CRAFT, as you will have noticed, prints a number of radio cartoons, which we intend to keep on publishing every month indefinitely. We invite our readers to contribute to this feature by sending in their ideas of humorous radio ideas which can be used in cartoon form. It is not necessary that you draw a sketch, but you may do so if you so desire.

RADIO-CRAFT will pay \$3.00 for each original idea submitted and accepted.

We cannot return ideas to this department nor can we enter into correspondence in connection with them. Checks are payable on publication.

Address all entries to RADIO CARTOONS, c/o RADIO-CRAFT, 25 West Broadway, New York 7, N. Y.



A combination radio crystal checker, invented by Technical Sergeant James T. Johnson at an American aircraft repair depot in England, has permitted salvage of more than 50,000 crystals from battle-damaged U. S. planes.

CORRECTION

An error in Fig. 3 of the article, "Dynamic Tube Tester" in November would prevent this instrument from operating. The condenser which is marked "C₁" in Figs. 1 and 2 is omitted. This 2-mfd. condenser should be included in the circuit in the position it occupies in the other figures.

40 YEARS OF HOME RADIO

(Continued from page 209)

in those days labor and materials were at a much lower level than that prevailing today and not much profit was realized at these prices.

Here is a list price of the outfit as advertised in one of the early catalogues of the E.I. Co.

No. 1086 Complete "Telimco" No. 2 Comprises:

- 1 one-inch spark coil, special tension, polished hardwood case; French improved vibrator, all trimmings polished brass. No. 1088 . . . \$5.00
- 1 pair adjustable brass jump spark balls, 1 3/4 inches, diameter, including polished supporting stands, binding posts, and two "send" wires. No. 111 . . . 1.15
- 1 Coherer with Automatic De-coherer and Sounder combined, including two "catch" wires. No. 1097 . . . 1.25
- 1 Seventy-five Ohm, Sensitive Relay, with knife edges. No. 1003 . . . 2.00
- 1 Wood Case Strap Key. No. 11825
- 5 Cells Dry Battery 2 1/2 x 6 inches. No. 1001 @ 16c80

Complete Outfit, boxed . . . 10.00

It will be noted that this modest price included a good deal of equipment. The components being rugged, we had few complaints worth speaking about.

The accompanying two photographs show an exact replica of the original outfit, built by the writer, to commemorate the 40th anniversary of the first Home Radio Set.

The transmitter, aside from the batteries and key, was composed of a one-inch spark coil. The "one-inch" here means that the coil threw a one-inch spark through free air, between wire points. Mounted on the spark coil, by means of two metal standards were two brass oscillator balls, between which a small blue spark jumped the 1/8-inch gap. The spark coil had a fast vibrator, so that every time you depressed the key, a spark would jump between the two balls. Depressing the key for a short period would give a dot, depressing it for a longer period would give a dash.

The receiver was composed of a 75 ohm "pony" relay which had to be so sensitive that if you slightly blew your breath against the armature its contacts would close. Then there was a single dry cell and the all important coherer. This coherer was constructed merely of two large, double binding posts through the bottom holes of which passed two silver-plated brass rods. A glass tube, placed between the two binding posts, was slipped over the two brass rods. These 1/8-inch metal rods fitted the glass perfectly, so that there was little, or no play. The two rods were separated about 3/16 of an inch, forming a gap. This gap was then filled with the "soul of the set"—the coherer filings. It took months of experimenting to get the coherer to work perfectly and the method which the writer finally used was as follows:

At first we used to break the law, days on end, by taking dimes and filing them down because we needed silver for the filings. Later on we went to a silver supply house and bought silver bars which in the end proved cheaper. Here it is most important to note that the filings cannot be made with any old file. You must have a very coarse file, a so-called rasp file. We put the dime or the silver bar into the vise, firmly clamping it. Then we took the lid of a box and

(Continued on page 256)

Radio Servicemen:

RADIO PARTS—TUBES

BARGAIN PRICES—NO PRIORITIES

- King P.M. Speakers, 4 or 5 inch . . . \$1.19
- King 450 Ohm Speakers, 4 or 5 inch . . . 1.49
- Filter Cond., 20-20 Mfd., 150 V. . . .39
- By-Pass Cond., .05 or .1 Mfd., 600 V. . . .07

Write Today for Bargain Bulletin

RADIO DISTRIBUTING COMPANY
P.O. Box 497—PASADENA 18, California

Index to advertisers

Allied Radio Corporation	236
American Microphone Co.	200
Amperite Co.	243
Amplifier Co. of America	248
Adel & Company	
Opposite Inside Back Cover	
Best Vibrator Co.	242
Buck Mfg. Co.	250
Burgess Battery Co.	233
Burstein-Applebee Co.	237
Cannon Co., C. F.	233
Capitol Radio Eng. Institute	230
Cardwell Mfg. Co., Allen D.	246
Concord Radio Corporation	240
Coyne Electrical School	242, 244, 248
DeForest's Training, Inc.	199
Echophone Radio Co.	229
Fada of New York	244, back cover
Federal Telephone & Telegraph 202, 247	
General Cement Mfg. Co.	250
Hallicrafters Co., Inc.	195
Hazeltine Electronics Corp.	247
Henry Radio	241
Hudson Specialties	242, 249
Lancaster, Allwine & Rommel	242
Lear, Inc.	247
Lifetime Sound Equipment Co.	249
McElroy	250
McGraw-Hill Book Co.	255
Mallory & Co., Inc., P. R.	
Inside back cover	
Meissner Mfg. Co.	227
National Plans Institute	242
National Radio Institute	193
National Schools	201
National Union Radio Corporation	246, Opposite Page 193
Nelson Company	232
Onan & Sons, D. W.	251
Opportunity Adlets	250
Popular Homecraft	254

RADIO SCHOOL DIRECTORY

Page 256

- Candler System
- Capitol Radio Engineering Institute
- Commercial Radio Institute
- Lincoln Engineering School
- Melville Radio School
- Radio & Television Institute
- RCA Institutes
- Tri-State College

Radcraft Publications	238, 249, 253
Radio Distributing Co.	254
Radio Electric Service	239
Radio & Technical Division	
Murray Hill Book Co.	225
Raytheon Mfg. Co.	Inside front cover
RCA Communications	247
Rider Publisher, Inc., John F.	235
Solar Capacitor Sales Co.	
Opposite Inside Front Cover	
Sperry Gyroscope Co., Inc.	
Opposite Page 256	
Sprague Products Co.	198
Sprayberry Academy of Radio	197
Sun Radio Corp.	246
Supreme Instruments	234
Sylvania Electric Co.	196
Technifax	244, 252
Western Electric Co.	246
Wholesale Radio Laboratories	237

BOOK REVIEWS

RADIO'S 100 MEN OF SCIENCE, by Orrin E. Dunlap, Jr. Published by Harper & Brothers. Stiff cloth covers, 6 x 9 inches, 294 pages. Price \$3.50.

A biographical encyclopedia of the men who are responsible for radio has long been needed. The present book fills that need in a style at once popular and technically accurate. The author's training, first as radio journalist with the *New York Times* and afterward on the executive staff of the Radio Corporation of America, has fitted him to use such a style.

The book is divided into two parts, "Pioneers of Electricity" and "Pioneers of the Radio Age." The first section concentrates on men whose work formed part of that line of discoveries which led to communication without wires. It begins with Thales of Miletus, who called men's attention to the electric spark five centuries before our era. Nineteen characters are reviewed, the last being Mahlon Loomis, who lapped over into the Radio Age with his patent for a wireless telegraphy system in 1872.

The remaining eighty-one characters begin with David E. Hughes, student of the microphone, and end with several contemporary workers in radio whose story is yet incomplete. Among these latter are a number of specialists best known only in their own branch of endeavor. Of such are Harry F. Olson, expert in acoustics, the results of whose work are heard by the entire population of the country, but who is known to few; and Paul Nipkow, pre-television inventor, whose name will be familiar only to those who remember the Nipkow disc.

In a book of this type, readers with differing viewpoints are bound to note apparent omissions or superfluous figures. These are not likely to be numerous enough to make it less valuable as a technical reference and will have no effect on it as an excellent and interesting popular work for the general reader.

MEET THE ELECTRON, by David Grimes. With pen illustrations by J. Riegel, Jr. Pitman Publishing Corporation. Stiff cloth covers, 5½ x 8½ inches, 120 pages. Price \$2.00.

The untimely death of the author in an airplane crash in North Ireland while in the service of his country delayed the publication of this book, and, it is said, prevented its expansion in certain sections. As it stands, however, it is an almost perfect popularization of some of the more difficult phases of electronics, even including television.

Starting with a description of the electron and a short historical outline, the author proceeds in the simplest language and with the help of excellent drawings to explain the nature and actions of electrons, current and static electricity and magnetism. Never once does the language drop into that of the textbook—the reader is kept in complete ignorance of the fact that he is being "taught" anything.

The same method is continued throughout the chapters on vacuum tubes, radio and radio waves, and television. An especially interesting illustration, which arouses the reader's curiosity from page 63 to page 100, is that of the scanning action of electron beams in the television apparatus.

Some of the analogies, as the author points out, are a little wide, absolute technical accuracy being sacrificed in the interests of presenting general truth in a simple and understandable form. This will be appreciated by the beginner, who will be the chief beneficiary of this last work of a great radioman and radio teacher.

MODERN RADIO, by Kingdon S. Tyler. Published by Harcourt, Brace and Company. Stiff cloth covers, 6 x 8½ inches, 238 pages. Price \$2.50.

"Modern Radio" is a popular book of a specialized type. It deals with broadcasting, beginning with the studio and continuing through all the details of the transmitting art to colored television.

The first chapters give an excellent description of the broadcasting studio. While the treatment is non-technical, some of the details of sound conditioning and reverberation control are distinctly interesting to the technician who has not had an opportunity to familiarize himself with broadcasting practice. This technique is described at length, and illustrated with drawings of acoustivanes and details of floor construction showing how studios are isolated from pickup of external sound.

Microphones, studio and master control rooms, the transmitter and the broadcast antenna receive a chapter each. The author then discusses frequency modulation and international broadcasting. Three chapters are devoted to television and one to radar.

The book is well illustrated with photographs and drawings.

ELECTRONICS FOR RADIO MEN AND ELECTRICIANS, by the Technical Staff, Coyne Electrical School. Published by the Coyne Electrical School. Stiff leatherette covers, 6 x 9 inches, 412 pages. Price \$4.95.

Listed as "a practical manual for home study and job use covering operation, installation, maintenance, testing and trouble shooting," this is a full size instruction manual in practical electronics, written at the serviceman's level.

Beginning with electron theory and the operation of an electron tube, the first few chapters handle electronic fundamentals in a manner similar to older texts, with the notable difference that tubes described and examples taken are from industrial electronic apparatus rather than radio equipment. The triode is not mentioned until thyratrons are reviewed in the seventh and succeeding chapters.

Besides the thyatron, ignitrons, grid-glow tubes, phototubes, timing circuits, welding controls and relays are described. Electronic heating is given one chapter, and relays are discussed in connection with phototubes. The cathode-ray tube is also discussed fully.

The electronic apparatus described is thoroughly and practically related to the industrial equipment it controls, and sufficient information about that equipment is given to enable the new electronic serviceman to understand what he is about. The book closes with a chapter on maintenance and trouble shooting. The table of contents carries all section headings, thus becoming a sort of directory. A complete index is included as well.

NOW—A REALLY HIGH-POWERED— Radio Engineering Library

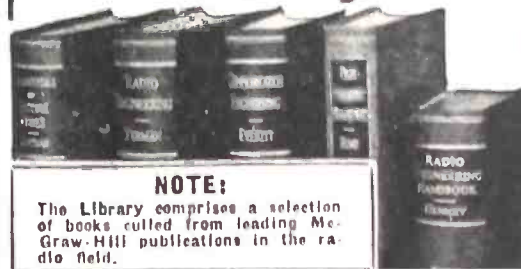

NOTE:

The Library comprises a selection of books culled from leading McGraw-Hill publications in the radio field.

- especially selected by radio specialists of McGraw-Hill publications
- to give most complete, dependable coverage of facts needed by all whose fields are grounded on radio fundamentals
- available at a special price and terms

THESE books cover circuit phenomena, tube theory, networks, measurements, and other subjects—give specialized treatments of all fields of practical design and application. They are books of recognized position in the literature—books you will refer to and be referred to often. If you are a practical designer, researcher or engineer in any field based on radio, you want these books for the help they give in hundreds of problems throughout the whole field of radio engineering.

5 VOLUMES, 3319 PAGES, 2289 ILLUSTRATIONS

1. Eastman's FUNDAMENTALS OF VACUUM TUBES
2. Terman's RADIO ENGINEERING
3. Everitt's COMMUNICATION ENGINEERING
4. Hund's HIGH FREQUENCY MEASUREMENTS
5. Henney's RADIO ENGINEERING HANDBOOK

10 days' examination. Easy terms. Special price under \$3.00, plus few cents postage, and \$3.00 monthly till \$24.00 is paid; or return books postpaid. (We pay postage on orders accompanied by remittance of first installment.)

10 DAYS' FREE EXAMINATION—SEND COUPON

McGraw-Hill Book Co., 330 W. 42nd St. New York 18

Send me Radio Engineering Library, 5 vols., for 10 days' examination on approval. In 10 days I will send \$3.00, plus few cents postage, and \$3.00 monthly till \$24.00 is paid; or return books postpaid. (We pay postage on orders accompanied by remittance of first installment.)

Name

Address

City and State

Position

Company RC 1-45

RADIO DATA CHARTS, by R. T. Beatty. Third Edition. Revised by J. McG. Sowerby. Published by *Wireless World* (England). Flexible fiber covers, end opening, 8½ x 10½ inches, 85 pages. Price 7s. 6d.

Readers of the British *Wireless World* are familiar with these calculation-simplifying nomograms which range from the design of a coil to combine maximum inductance with minimum D.C. resistance to the selection of coil-condenser combinations for loudspeaker frequency-dividing networks. The present book collects forty of these charts between one pair of covers.

To those engineers familiar with the second edition, it may be said that 11 charts have been redrawn and 10 are new in the third edition. The new charts include two which extend inductance-capacity-frequency calculations to cover the I.F. and audio range; effects of shielding on R.F. inductance and resistance; four charts dealing with transmission lines; and charts on output transformer ratios and on speaker dividing networks.

Nomograms other than those mentioned include inductance of single-layer solenoids; R.F. and D.C. resistance of coils and their ratios; reactance of coils and condensers at radio and audio frequencies; power transformers (four charts); design of chokes; and a number of the more common nomograms designed to speed up some of the more simple radio calculations.

RADIO SCHOOL DIRECTORY

PREPARE NOW FOR POST-WAR RADIO AND ELECTRONICS

MAKE a place for yourself in a new world of radio and electronics—a world in which revolutionary electronic developments will require highly specialized technical knowledge. Take a good course now to fit yourself for a good paying job. The training you need can be supplied by one of the schools advertised in this publication.

RADIO-TELEVISION ELECTRONICS

offer ever-increasing post-war opportunities for trained men and women. R-T courses prepare you by combining theory with practical laboratory experience.

Consideration given to Veterans eligible for training under the G. I. Bill. Day & Evening Sessions. Apply daily 9-9, Sat. 9-2. Request Information.

Radio-Television Institute

480 Lexington Avenue, N. Y. 17 (46th St.) PLaza 3-4585 Licensed by N. Y. State



INSTITUTES

Offer thorough training courses in all technical phases of

Radio and Television

DAYS—EVENINGS WEEKLY RATES

VETERANS: RCA Institutes is approved under G. I. Bill of Rights

For Free Catalog Write Dept. RC-45

RCA INSTITUTES, Inc.

A Radio Corporation of America Service 75 VARICK STREET NEW YORK 13, N. Y.



Correspondence Courses in RADIO and ELECTRICAL ENGINEERING

ELECTRICAL ENGINEERING Get good grasp of wide electrical field. Prepare yourself, at Low Cost, for secure future. Modern, simplified, you can understand quickly.

RADIO ENGINEERING Extra fine course in radio, public address, photo-electric work. Train you to be super-service man, real vacuum tube technician. Servicemen needed badly. Diploma on completion. Tuition \$25, either course. Deferred payment plan.

FREE Get copies of school catalogs, student magazines, complete details. **SEND NOW!**

LINCOLN ENGINEERING SCHOOL Box 61-C71 Lincoln, Nebr.

SENDING SPEED

CODE RECEIVING

Be a "key" man. Learn how to send and receive messages in code by telegraph and radio. Army, Navy and Commerce need thousands of men. Good pay, adventure, interesting work. Learn at home quickly through famous Candler System. Write for **FREE BOOK**.

CANDLER SYSTEM CO.
Dept. 3-A, Box 928, Denver 1, Colo., U.S.A.

MELVILLE RADIO INSTITUTE

"A Radio School
Managed by Radio Men"

45 W. 45 St. (Dept. RC) New York 19, N. Y.

RADIO ENGINEERING!

EX-SERVICE MEN can complete work here in shortest possible time. Special Prep. Dep't. Also **REFRESHER COURSES**. Courses also in Civil, Electrical, Mechanical, Chemical, Aeronautical Engineering; Business Administration, Accounting, Secretarial Science. Tuition, living costs low. 61st year. Cosmopolitan student body. Enter Jan., Mar., June, Sept. Catalog.

DEGREE IN 27 MONTHS

TRI-STATE COLLEGE 2415 College Ave. ANGOLA, INDIANA

COMMERCIAL RADIO INSTITUTE

A radio training center for twenty-four years.

ACCREDITED FOR VETERAN TRAINING
RESIDENT COURSES ONLY

Pre-Induction, Broadcast, Service, Aeronautical, Television and Marine telegraphy classes now forming for February 5th. Literature upon request.

Home Study Course in Mathematics
Dept. C., 38 West Biddle St., Baltimore 1, Md.

● ● ● **LOOK AT**
THE CAPITOL RADIO
ENGINEERING INSTITUTE
MESSAGE ON PAGE 230.

coherer bell which starts ringing furiously and shakes up the coherer filings. These now fly apart—they decohere—and the coherer becomes non-operative, till the next wave comes along.

From this it will be seen, that every time you press the transmitter key, the bell at the receiver will ring. It rings as long as you hold the key down. A long ring is a dash, a short ring a dot. Even if they did not know the Morse Code, in those days experimenters had a lot of fun watching the uncanny, almost magical, action of the apparatus.

You could pick up the receiver and walk around the room with it, yet the bell would ring mysteriously without any visible connection. You could even walk out of doors, or into the next room, with thick walls intervening and signals would still come in.

Of course, to do all this the relay would have to be adjusted carefully, so that the contacts would close at the slightest touch, or with an exceedingly weak current.

One of the things that bedevilled us in the early days, was the sparking at the relay contacts. This in turn would set up electromagnetic waves and often the outfit would not give clear signals; some times the bell would ring for long seconds after the signal. This was overcome by putting a high capacity condenser across the two relay points. Nowadays we can get a five microfarad condenser, which is best for this purpose, (electrolytic type) and mount it under the base of the relay where you cannot even see it. In the old days such a large capacity condenser would be as big as a standard dry cell battery.

The range of the TELIMCO Wireless Telegraph Outfit was between 300 to 500 feet, if used without any ground connection. By using a regular elevated aerial of 50 to 100 feet high and grounding one side of both transmitter and receiver to a water or gas pipe, the range was easily increased to one mile. Indeed hundreds of people who bought the outfit at the time reported excellent reception even over greater distances, but these of course were exceptions. Note that this particular set used *no tuning whatsoever*. The receiver was tuned to the transmitter by the simple process of making the receiver's aerial wires the same length as those of the transmitter. As is to be expected, a set of this type was not free from natural or man-made static. Thus, during a thunder storm the bell would ring long before you saw lightning. When a nearby electrical appliance switch was thrown, the decoherer would also ring, just as most radio receivers today will give a sharp click when you turn on the electric light, or when your refrigerator starts operating. In 40 years static has not changed much!

A curious thing about this little outfit today is its strange effect on radio people who never heard of the ancient spark coil and coherer sets. Young radio men, who have never seen one of these outfits, are usually very much perturbed and astonished when the writer demonstrates it. The reason of course is that people have difficulty realizing that with a little three dry cell transmitter it is possible to ring a bell through intervening walls while the novice is holding the receiver in his own hands.

It is conceivable that some time in the future these same instrumentalities may still find a use in modern radio and electronics, which may not be apparent today.

The writer is happy to give credit to J. H. Bunnell & Co. of New York, who furnished the 1-inch spark coil and 75 ohm pony relay; to Blan, the Radio Man, of New York, who furnished the spark-balls—all exact replicas of the original components used by the writer 40 years ago in the original TELIMCO outfit.

40 YEARS OF HOME RADIO (Continued from page 254)

made a hole the same size of the dime or the silver bar and started filing. This gave us good, coarse silver filings. Next we got a cloth mesh and separated the fine filings from the coarse. Only the big filings left were used.

After making a good supply of these silver filings they were put into a clean new bottle which was stoppered. Then we made a supply of iron filings. This required a good grade of soft, Swedish iron, which did not retain its magnetism, otherwise it would not be useable. After we had filled a bottle of soft, coarse iron filings too, we were now ready for the final step. This was accomplished by mixing the two types of filings in the following proportions:

Silver filings 10%.
Iron filings 90%.

This final mixture of filings was put in still another bottle which represented the end product. By shaking the mixture up well it was ready to be used. When used in a coherer the filings must always be loose, *never packed tight*.

Now the decoherer—an ordinary house bell—was mounted in such a manner that

the clapper of the bell would strike against the glass tube of the coherer at the exact spot where the filings were located. If the diagram, which is shown elsewhere, is studied, it will be seen that every time the relay closes its contacts, the bell will ring through the single battery.

Now then, if you depress the key at the transmitter, the two aerials (aerial and counterpoise) will emit radio waves. Curiously enough it should be noted that the waves which the writer used in those days, 40 years ago, were of the ultra-short variety, to which radio is now coming back. The two aerial wires of the transmitter measured less than a foot and a half.

Inasmuch as the coherer is directly in the aerial circuit, an interesting phenomenon now takes place, which incidentally was discovered by the Russian Popoff. The filings, previously a very high resistor, under the onslaught of the radio waves instantaneously become an excellent conductor—as if they now were a solid piece of wire. The relay, which is also in the circuit now goes into action, attracting its armature which closes its contacts. This in turn sets off the de-



The Greeks gave us a word for it . . . now we give it to you

WHEN Sperry first developed its velocity-modulated, ultra-high-frequency tube, the word "KLYSTRON" was registered as the name of the new device.

This name — from the Greek, as coined by scientists of Stanford University — is an apt description of the bunching of electrons between spaced grids within the tube.

"Klystron" is a good name. So good, that it has come into widespread use as the handy way to designate *any* tube of its general type,

whether a Sperry product or not.

This is perfectly understandable. For the technical description of a Klystron-type tube is unwieldy, whether in written specifications, in conversation, or in instructing members of the Armed Forces in the operation of devices employing such tubes.

These conditions have prompted many requests from standardization agencies—including those of the Army and Navy—for unrestricted use of the name Klystron. In the public interest, Sperry has been glad to

comply with these requests . . .

From now on, the name KLYSTRON belongs to the public, and may be used by anyone as the designation for velocity-modulated tubes of any manufacture.

Sperry will, of course, continue to make the many types of Klystrons it now produces, and to develop new ones.

On request, information about Klystrons will be sent, subject to military restrictions.

SPERRY GYROSCOPE COMPANY, INC. GREAT NECK, N. Y.

Division of the Sperry Corporation

★
LOS ANGELES • SAN FRANCISCO • NEW ORLEANS
HONOLULU • CLEVELAND • SEATTLE

GYROSCOPICS • ELECTRONICS • RADAR • AUTOMATIC COMPUTATION • SERVO-MECHANISMS

**NEW EDITION
NOW READY**

Audels RADIOMANS GUIDE

Includes **TELEVISION
AND ELECTRONICS**

LARGER - MORE COMPLETE - 914 PAGES - 633 ILLUS - WIRING DIAGRAMS - PHOTOS

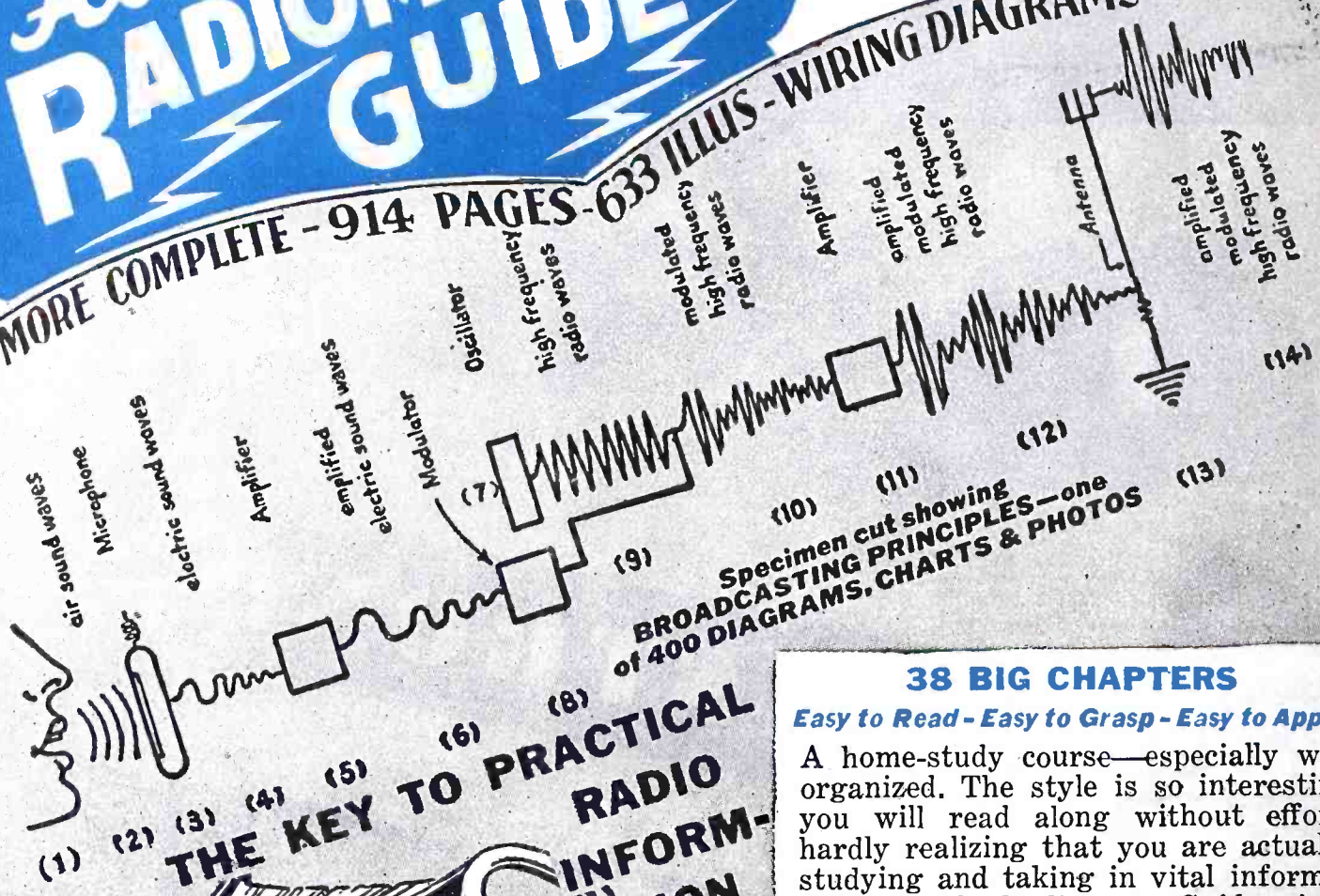

**Specimen cut showing
BROADCASTING PRINCIPLES—one
of 400 DIAGRAMS, CHARTS & PHOTOS**

**THE KEY TO PRACTICAL
RADIO
INFORMATION**

It gives you in usable form pointers on radio, including frequency modulation, television, etc. Also valuable inside information for Aviators, Marines, Commercial Operators and Technicians, Servicemen and Students.



**Q AND A
UNIQUE
QUESTION
and
ANSWER
METHOD**

Highly Endorsed

38 BIG CHAPTERS

Easy to Read - Easy to Grasp - Easy to Apply

A home-study course—especially well organized. The style is so interesting you will read along without effort, hardly realizing that you are actually studying and taking in vital information. Audels Radiomans Guide gives you just the right amount of mathematics required to cope with radio problems successfully. You can solve, with the aid of this extraordinary book, practically every radioproblem that comes up. At your finger tips is a complete index for instant use.



**1001 RADIO FACTS AND FIGURES
A Complete Library In One Book**

AUDELS RADIOMANS GUIDE gives authentic Principles and Practices in Construction, Operation, Service and Repairs. Covers clearly and concisely radio fundamentals—Ohm's Law—Physics of sound as related to radio science—Measuring instruments—Power supply—Resistors—Inductors—Condensers—Transformers and examples—Broadcasting stations—Radio Telephony—Receivers—Diagrams—Construction—Control Systems—Loudspeakers—Antennas—AutoRadio—Phonograph Pick-ups—Public Address Systems—Aircraft and Marine Radio—Radio Compass—Beacons—Automatic Radio Alarms—Short Wave—Coil Calculations—Testing—Cathode Ray Oscillographs—Static Eliminations—Trouble Pointers—Underwriter's standards—Units and tables. REVIEW QUESTIONS—READY Reference Index.

**\$ 4 COMPLETE
\$ 1 PAY ONLY 1 MO.**

7 DAYS' FREE TRIAL
THEO. AUDEL & CO., Publishers
49 West 23rd Street, New York 10, N. Y.

Mail AUDELS NEW RADIOMANS GUIDE for free examination. If O. K. I will send you \$1 in 7 days; then remit \$1 monthly until \$4 is paid. Otherwise I will return it.

Name _____
Address _____
Occupation _____
Reference _____

**MAIL THIS
COUPON
TODAY**

RCF



WHO is This Man?

HE'S purchasing agent, technical adviser, expeditor, merchandiser all rolled into one. He's your Mallory Precision Products Distributor—carefully selected for integrity, knowledge and qualities of leadership to give you outstanding service. His stock is the finest that Mallory makes—as complete as wartime conditions permit. And his experience is yours for the asking: to help you with ALL your radio procurement problems.

Your Mallory distributor is a good man to know and do business with. He's an *expert* on saving you time and money.

...and What Does He Offer the Service Engineer?

1

A complete line of Mallory replacement parts . . . many of them first developed by Mallory research . . . ALL of them guaranteed against premature failure by years of service in the field.

2

A program of standardization that meets the maximum number of application needs with the minimum number of parts . . . reduces investment, simplifies replacement, speeds up delivery.

3

Efficient service . . . backed by detailed information on prices, parts, catalog numbers . . . promptly applied whether orders are large or small . . . especially effective in meeting emergencies.

4

Technical service helps . . . bulletins, booklets, catalogs, letters, with complete data on what to use and where to use it . . . special publications on radio fundamentals and new developments.

5

A background of personal experience . . . acquired through years of service in radio . . . helpful in solving difficult or unusual problems . . . effective in training dealer personnel.

6

Commercial "know how" . . . implemented by sound methods of keeping your business on the beam . . . with special attention to promotion devices that help sell your story to the public.

The Part Your Mallory Distributor Plays Is Important TODAY—to YOU!

P. R. MALLORY & CO., Inc., INDIANAPOLIS 6, INDIANA



*More than ever—
ALWAYS
INSIST ON*

P. R. MALLORY & CO. Inc.
MALLORY
APPROVED
PRECISION PRODUCTS

**VIBRATORS • VIBRAPACKS* • CONDENSERS
VOLUME CONTROLS • SWITCHES • RESISTORS
FILTERS • RECTIFIERS • POWER SUPPLIES**

ALSO MALLORY "TROPICAL" DRY BATTERIES, ORIGINALLY DEVELOPED BY MALLORY FOR THE U.S. ARMY SIGNAL CORPS, NOT PRESENTLY AVAILABLE FOR CIVILIAN USE.

* Trademark

1945

1945 dawns clear and bright . . . with new hope on the horizon . . . a hard-to-restrain spirit of optimism rewarding a nation unified in pursuit of Victory. Until Peace has been won, we at FADA are devoting all our resources and energies to the war effort. Our post-war promise will be revealed in performance.

PLACE YOUR FAITH
IN THE

FADA Radio

OF THE FUTURE

Famous Since Broadcasting Began!

FADA RADIO AND ELECTRIC COMPANY, INC., LONG ISLAND CITY, N. Y.

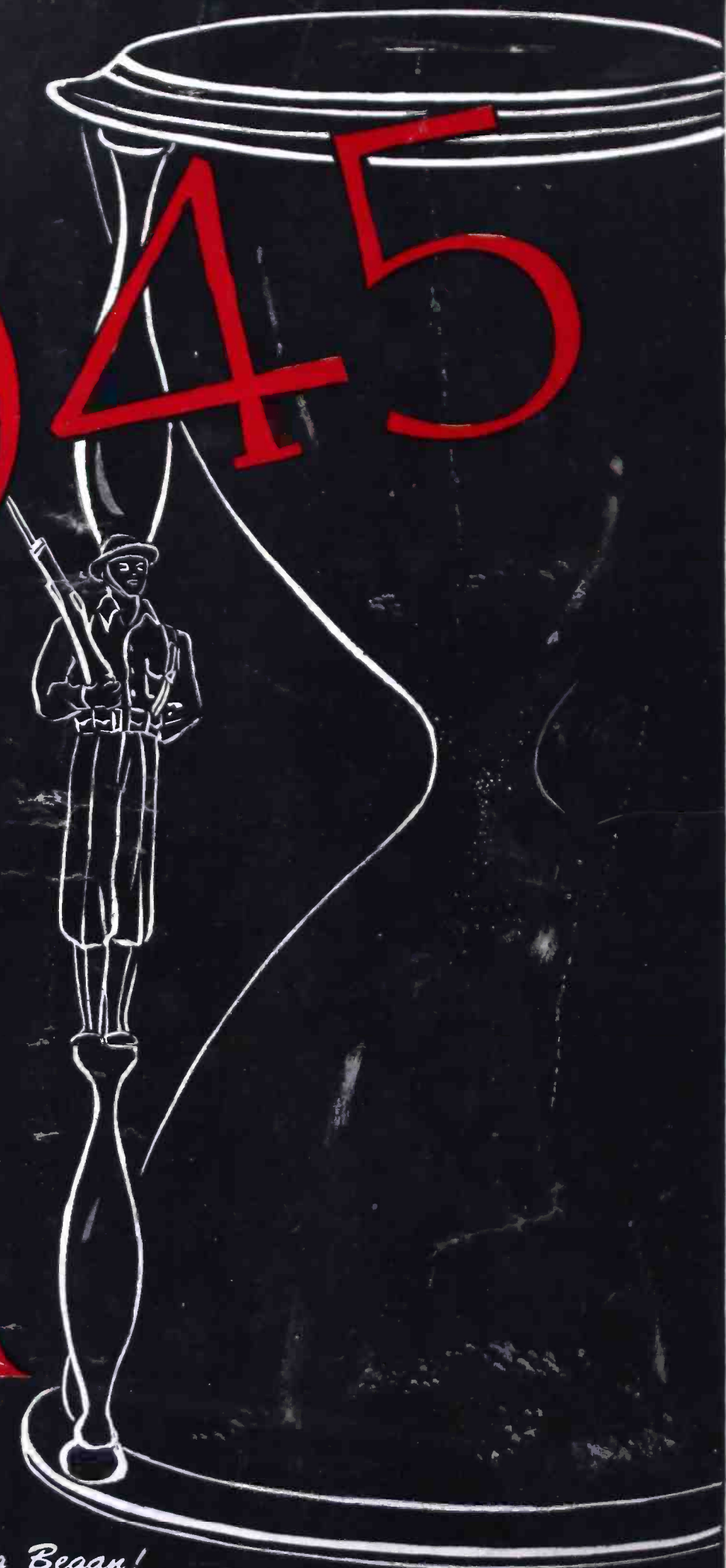

ADV Plans, LLC

Copyright Notice:

The entire contents of this CD/DVD are copyright 2014 by ADV Plans, LLC. All Rights Reserved.

Reproduction or distribution of this disk, either free or for a fee is strictly prohibited. We actively monitor and remove listings on eBay thru Vero.

You are free to copy or use individual images in your own projects, magazines, brochures or other school projects.

Only the sellers listed here are authorized distributors of this collection:
www.theclassicarchives.com/authorizedsuppliers

Please view our other products at
www.theclassicarchives.com,
or our ebay stores:

[TheClassicArchives](#)
[ADVPlans](#)
[SuperShedPlans](#)

